

ABC846BPN-HF (NPN PNP)

RoHS Device
Halogen Free

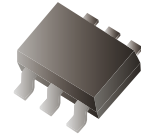

Features

- Low collector capacitance.
- Low collector-emitter saturation voltage.
- Reduces number of components and board space.
- No mutual interference between the transistors.
- AEC-Q101 Qualified.

Mechanical data

- Case: SOT-363, molded plastic.

Circuit Diagram

B :Base
E :Emitter
C :Collector

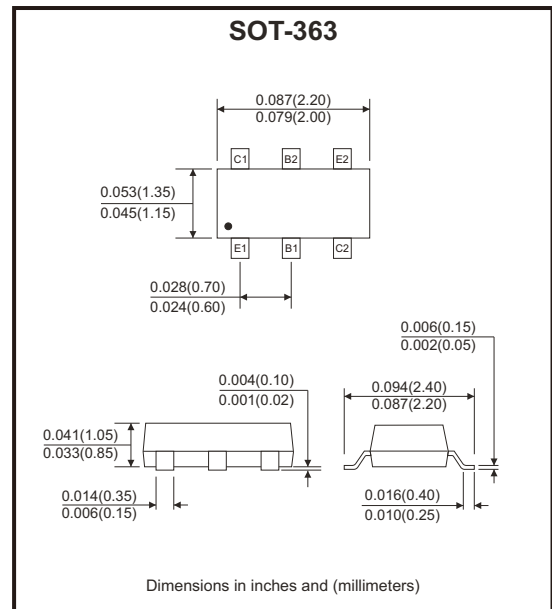
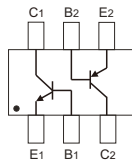

Maximum Ratings (Ta=25°C unless otherwise noted)

Parameter	Symbol	NPN	PNP	Unit
Collector-base voltage	V_{CBO}	80	-80	V
Collector-emitter voltage	V_{CEO}	65	-65	V
Emitter-base voltage	V_{EBO}	6	-6	V
Collector current-continuous	I_C	100	-100	mA
Collector current-peak	I_{CM}	200	-200	mA
Base current-peak	I_{BM}	200	-200	mA
Power dissipation	P_D	200		mW
Thermal resistance, junction to ambient	$R_{\theta JA}$	625		°C/W
Ambient temperature range	T_{amb}	-55 to +150		°C
Junction and storage temperature range	T_J, T_{STG}	-65 to +150		°C

Electrical Characteristics of TR1 NPN Transistor (Ta= 25°C unless otherwise specified)

Parameter	Symbol	Test Conditions	Min.	Typ.	Max.	Unit
Collector-base breakdown voltage	$V_{(BR)CBO}$	$I_C = 10\mu A, I_E = 0$	80			V
Collector-emitter breakdown voltage	$V_{(BR)CEO}$	$I_C = 10mA, I_B = 0$	65			V
Emitter-base breakdown voltage	$V_{(BR)EBO}$	$I_E = 10\mu A, I_C = 0$	6			V
Collector cut-off current	I_{CBO}	$V_{CB} = 50V, I_E = 0$			15	nA
Emitter cut-off current	I_{EBO}	$V_{EB} = 6V, I_C = 0$			100	nA
DC current gain	h_{FE}	$V_{CE} = 5V, I_C = 10\mu A$		280		
		$V_{CE} = 5V, I_C = 2mA$	200	290	450	
Collector-emitter saturation voltage	$V_{CE(sat)}$	$I_C = 10mA, I_B = 0.5mA$		0.05	0.1	V
		$I_C = 100mA, I_B = 5mA$		0.2	0.3	
Base-emitter saturation voltage	$V_{BE(sat)}$	$I_C = 10mA, I_B = 0.5mA$		0.755	0.85	V
		$I_C = 100mA, I_B = 5mA$		1	-	
Base-emitter voltage	$V_{BE(on)}$	$V_{CE} = 5V, I_C = 2mA$	0.58	0.65	0.7	V
		$V_{CE} = 5V, I_C = 10mA$	-	-	0.77	
Transition frequency	f_T	$V_{CE} = 5V, I_C = 10mA, f = 100MHz$	100			MHz
Collector capacitance	C_c	$V_{CB} = 10V, f = 1MHz$		1.9		pF
Emitter capacitance	C_e	$V_{CB} = 0.5V, f = 1MHz$		11		pF

Electrical Characteristics of TR2 PNP Transistor (Ta= 25°C unless otherwise specified)

Parameter	Symbol	Test Conditions	Min.	Typ.	Max.	Unit
Collector-base breakdown voltage	$V_{(BR)CBO}$	$I_C = -10\mu A, I_E = 0$	-80			V
Collector-emitter breakdown voltage	$V_{(BR)CEO}$	$I_C = -10mA, I_B = 0$	-65			V
Emitter-base breakdown voltage	$V_{(BR)EBO}$	$I_E = -10\mu A, I_C = 0$	-6			V
Collector cut-off current	I_{CBO}	$V_{CB} = -50V, I_E = 0$			-15	nA
Emitter cut-off current	I_{EBO}	$V_{EB} = -6V, I_C = 0$			-100	nA
DC current gain	h_{FE}	$V_{CE} = -5V, I_C = -10\mu A$		280		
		$V_{CE} = -5V, I_C = -2mA$	200	290	450	
Collector-emitter saturation voltage	$V_{CE(sat)}$	$I_C = -10mA, I_B = -0.5mA$		-0.055	-0.1	V
		$I_C = -100mA, I_B = -5mA$		-0.2	-0.3	
Base-emitter saturation voltage	$V_{BE(sat)}$	$I_C = -10mA, I_B = -0.5mA$		-0.755	-0.85	V
		$I_C = -100mA, I_B = -5mA$		-0.9	-	
Base-emitter on voltage	$V_{BE(on)}$	$V_{CE} = -5V, I_B = -2mA$	-0.6	-0.65	-0.75	V
		$V_{CE} = -5V, I_B = -10mA$	-	-	-0.82	
Transition frequency	f_T	$V_{CE} = -5V, I_C = -10mA, f = 100MHz$	100			MHz
Collector capacitance	C_c	$V_{CB} = -10V, f = 1MHz$		2.3		pF
Emitter capacitance	C_e	$V_{CB} = -0.5V, f = 1MHz$		10		pF

Rating and Characteristic Curves (ABC846BPN-HF)

Fig.1 - TR1 (NPN): DC Current Gain as a Function of Collector Current; Typical Values

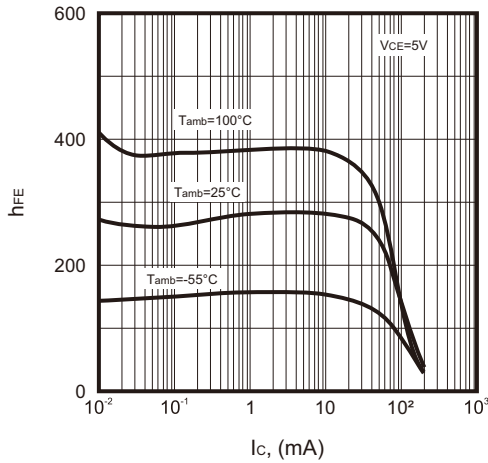

Fig.2 - TR1 (NPN): Collector Current as a Function of Collector-Emitter Voltage; Typical Values

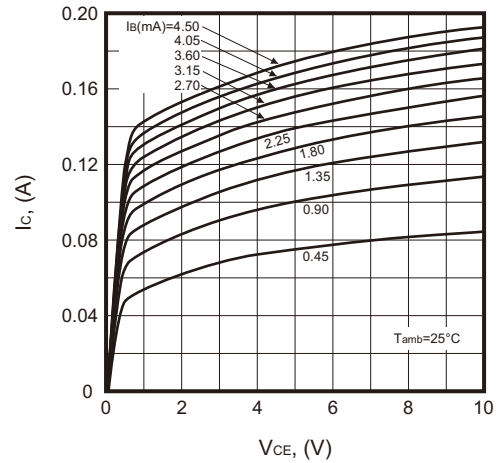

Fig.3 - TR1 (NPN): Base-Emitter Voltage as a Function of Collector Current; Typical Values

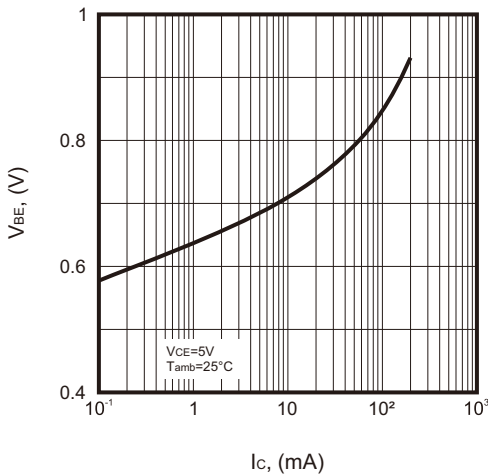

Fig.4 - TR1 (NPN): Base-Emitter Saturation Voltage as a Function of Collector Current; Typical Values

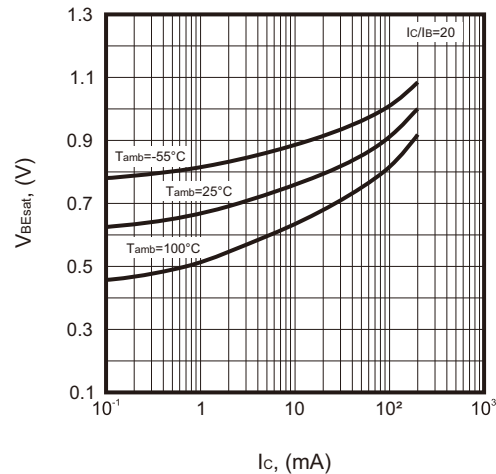

Fig.5 - TR1 (NPN): Collector-Emitter Saturation Voltage as a Function of Collector Current; Typical Values

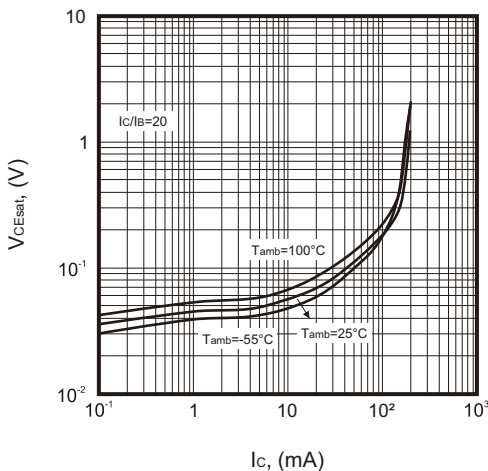
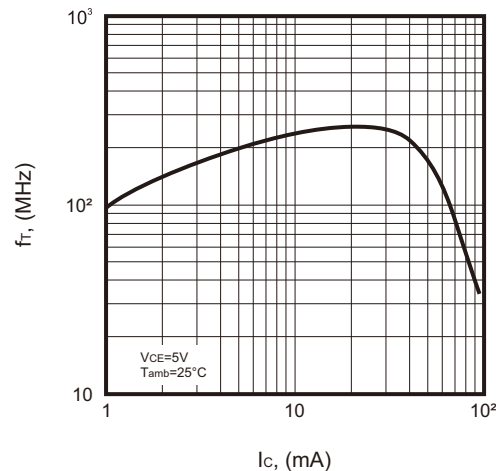

Fig.6 - TR1 (NPN): Transition Frequency as a Function of Collector Current; Typical Values



Company reserves the right to improve product design, functions and reliability without notice.

REV:A

Rating and Characteristic Curves (ABC846BPN-HF)

Fig.7 - TR2 (PNP): DC Current Gain as a Function of Collector Current; Typical Values

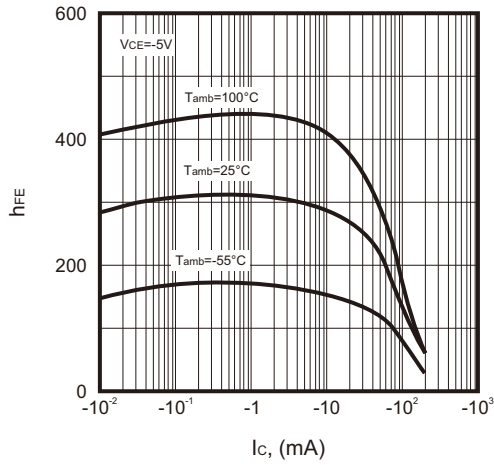
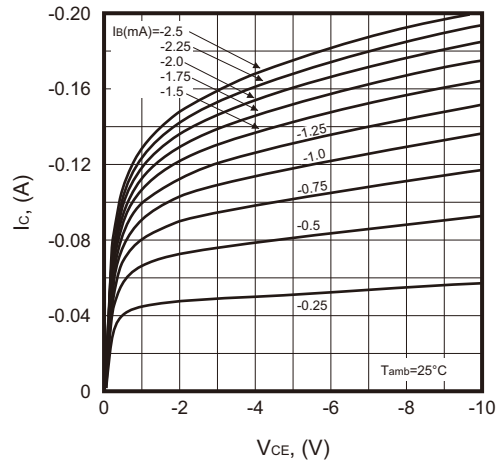
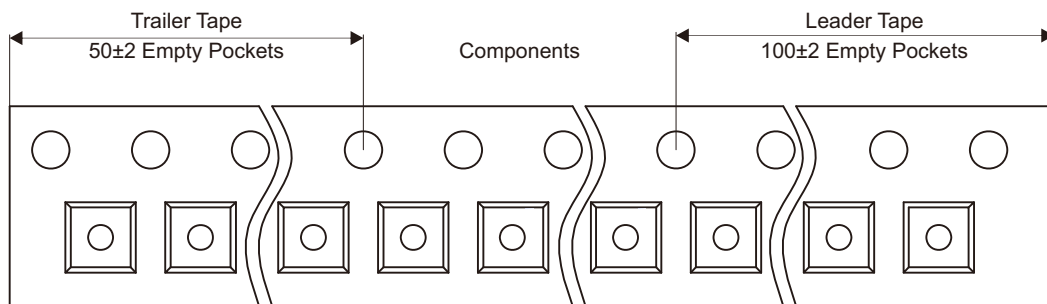
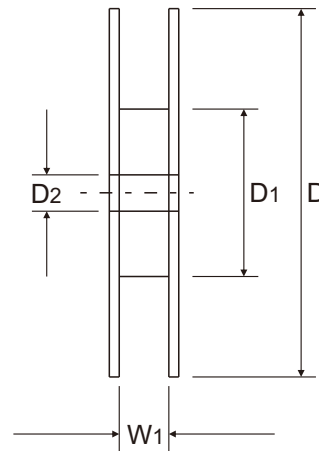
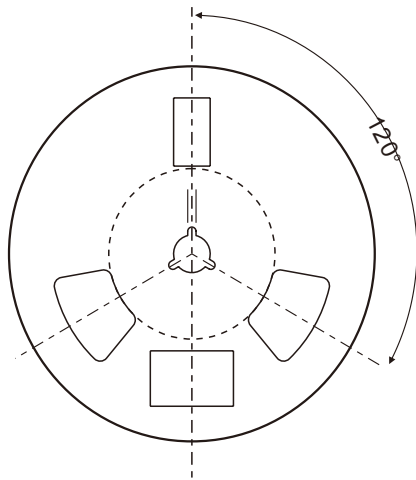
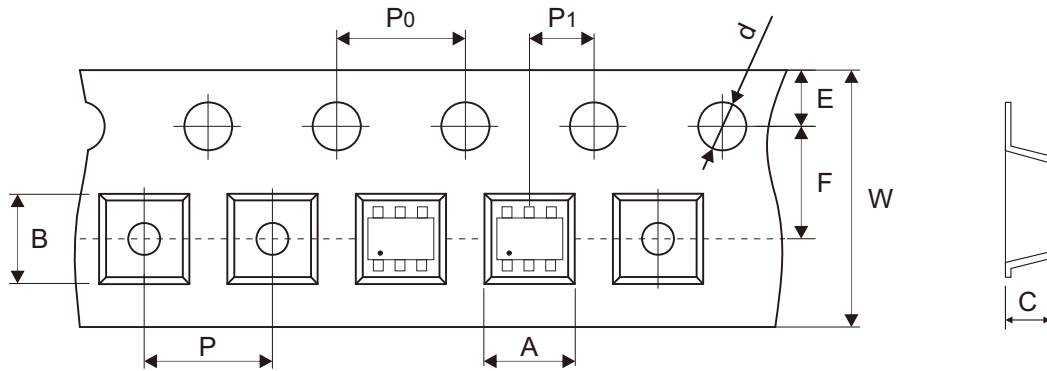

Fig.8 - TR2 (PNP): Collector Current as a Function of Collector-Emitter Voltage; Typical Values



Reel Taping Specification



SOT-363	SYMBOL	A	B	C	d	D	D1	D2
	(mm)	2.40 ± 0.10	2.40 ± 0.10	1.20 ± 0.10	1.50 ± 0.10	178.00 ± 1.00	54.00 ± 0.50	13.00 ± 0.50
	(inch)	0.094 ± 0.004	0.094 ± 0.004	0.047 ± 0.004	0.059 ± 0.004	7.008 ± 0.039	2.126 ± 0.020	0.512 ± 0.020

SOT-363	SYMBOL	E	F	P	P0	P1	W	W1
	(mm)	1.75 ± 0.10	3.50 ± 0.05	4.00 ± 0.10	4.00 ± 0.10	2.00 ± 0.05	8.00 + 0.30 - 0.10	9.50 ± 1.00
	(inch)	0.069 ± 0.004	0.138 ± 0.002	0.157 ± 0.004	0.157 ± 0.004	0.079 ± 0.002	0.315 + 0.012 - 0.004	0.374 ± 0.039

Company reserves the right to improve product design, functions and reliability without notice.

REV:A

Marking Code

Part Number	Marking Code
ABC846BPN-HF	PJ

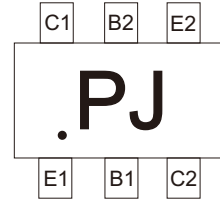

Solid dot “ • ” = Pin 1 indicate.

Suggested P.C.B. PAD Layout

SIZE	SOT-363	
	(mm)	(inch)
A	0.40	0.016
B	0.50	0.020
C	0.65	0.026
D	1.90	0.075

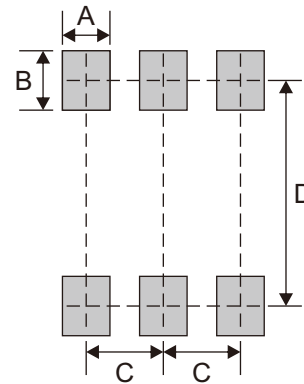

Note: 1. The pad layout is for reference purposes only.

Standard Packaging

Case Type	REEL PACK	
	REEL (pcs)	Reel Size (inch)
SOT-363	3,000	7

X-ON Electronics

Largest Supplier of Electrical and Electronic Components

Click to view similar products for [Bipolar Transistors - BJT category](#):

Click to view products by [Comchip manufacturer](#):

Other Similar products are found below :

[619691C](#) [MCH4017-TL-H](#) [BC546/116](#) [BC557/116](#) [BSW67A](#) [NTE158](#) [NTE187A](#) [NTE195A](#) [NTE2302](#) [NTE2330](#) [NTE63](#) [C4460](#)
[2SA1419T-TD-H](#) [2SA1721-O\(TE85L,F\)](#) [2SA2126-E](#) [2SB1204S-TL-E](#) [2SD2150T100R](#) [SP000011176](#) [FMMTA92QTA](#) [2N2369ADCSM](#)
[2N5769](#) [2SC2412KT146S](#) [2SC5490A-TL-H](#) [2SD1816S-TL-E](#) [2SD1816T-TL-E](#) [CMXT2207 TR](#) [CPH6501-TL-E](#) [MCH4021-TL-E](#)
[US6T6TR](#) [NJL0281DG](#) [732314D](#) [CMXT3906 TR](#) [CPH3121-TL-E](#) [CPH6021-TL-H](#) [873787E](#) [IMZ2AT108](#) [UMX21NTR](#) [MCH6102-TL-E](#)
[NJL0302DG](#) [2N3583](#) [2SA1434-TB-E](#) [2SC3143-4-TB-E](#) [2SD1621S-TD-E](#) [NTE103](#) [30A02MH-TL-E](#) [NSV40301MZ4T1G](#) [NTE101](#) [NTE13](#)
[NTE15](#) [NTE16001](#)