

ACDBC540-HF Thru. ACDBC5100-HF

Reverse Voltage: 40 to 100 Volts

Forward Current: 5.0 Amp

RoHS Device

Halogen free

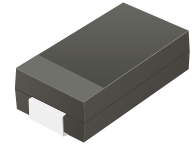

Features

- Low profile package.
- Ideal for automated placement.
- Guard ring for over voltage protection.
- Low forward voltage drop.
- AEC-Q101 Qualified

Mechanical data

- Case: DO-214AB / SMC, molded plastic.
- Epoxy: UL flammability classification rate 94V-0.
- Terminals: Lead free plating (Tin finish).
Solderable per MIL-STD-202, Method 208.
- Polarity: Indicated by cathode band.
- Weight: 0.231 grams (approx.).

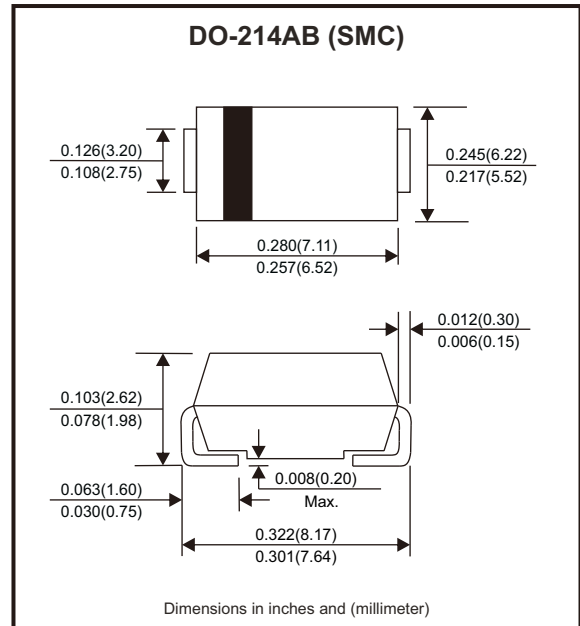

Circuit diagram



Maximum Ratings and Electrical Characteristics (at TA=25°C unless otherwise noted)

Parameter	Symbol	ACDBC540-HF	ACDBC560-HF	ACDBC5100-HF	Unit
Max. Repetitive peak reverse voltage	V_{RRM}	40	60	100	V
Max. RMS voltage	V_{RMS}	28	42	70	V
Max. DC blocking voltage	V_{DC}	40	60	100	V
Max. Average forward rectified current	I_F	5			A
Peak forward surge current, 8.3ms single half sine-wave superimposed on rated load	I_{FSM}	100			A
Max. Instantaneous forward voltage $I_F=5A @ 25^\circ C$	V_F	0.55	0.70	0.85	V
Max. DC reverse current @TA=25°C at Rated DC blocking voltage @TA=100°C	I_R	0.5 10		0.2 5.0	mA
Typical junction capacitance (Note 1)	C_J	300	210	170	pF
Typical thermal resistance	$R_{\theta JC}$	15			°C/W
Operating temperature range	T_J	-55 to +125		-55 to +150	°C
Storage temperature range	T_{STG}	-55 to +150			°C

Note: 1. Measured at 1.0MHz and applied reverse voltage of 4V DC.

Company reserves the right to improve product design, functions and reliability without notice.

REV:B

Rating and Characteristics Curvers (ACDBC540-HF Thru. ACDBC5100-HF)

Fig.1 - Typical Forward Current Derating Curve

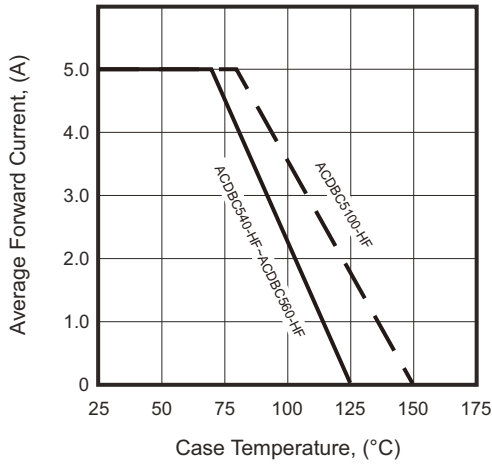

Fig.2 - Typical Forward Characteristics

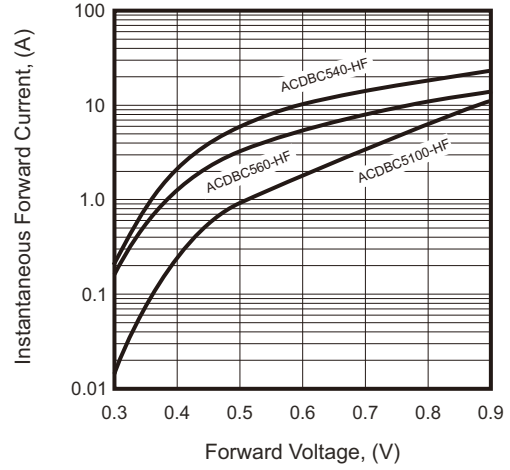

Fig.3 - Maximum Non-repetitive Forward Surge Current

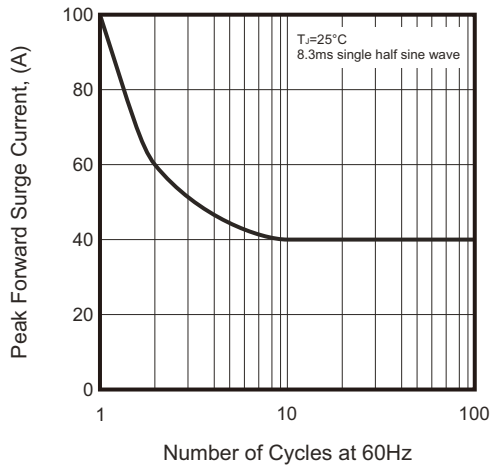

Fig.4 - Typical Reverse Characteristics

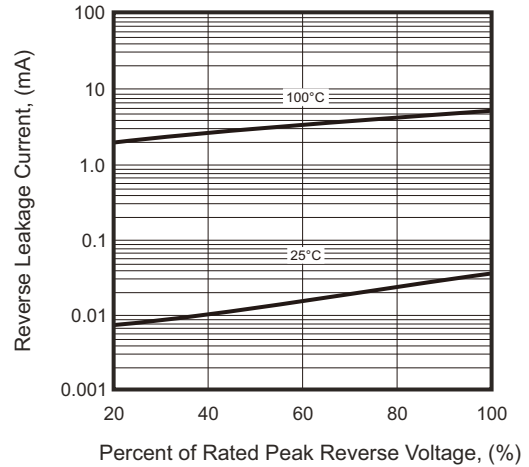
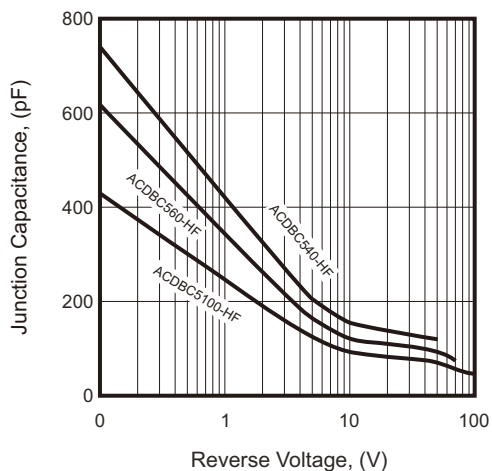
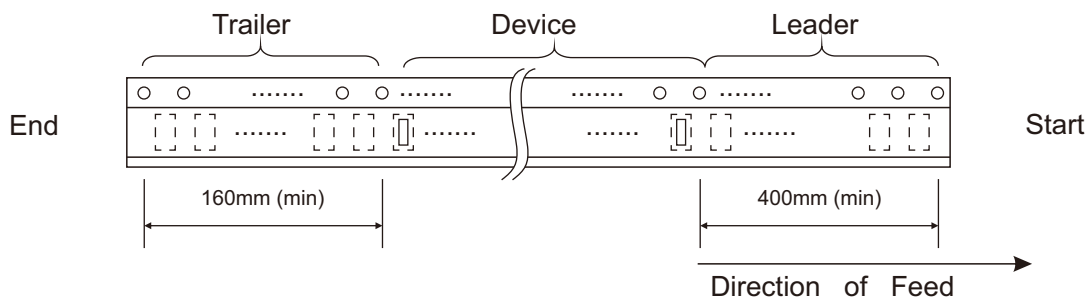
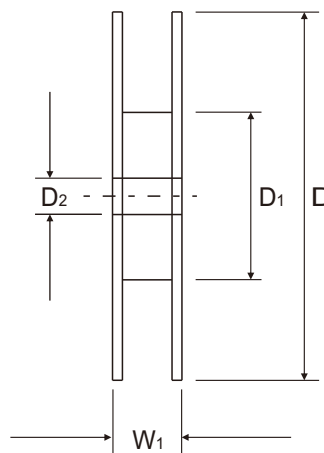
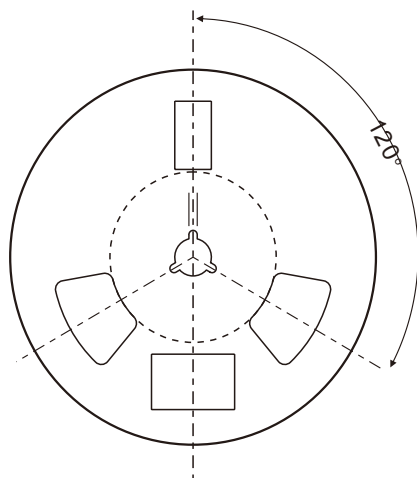
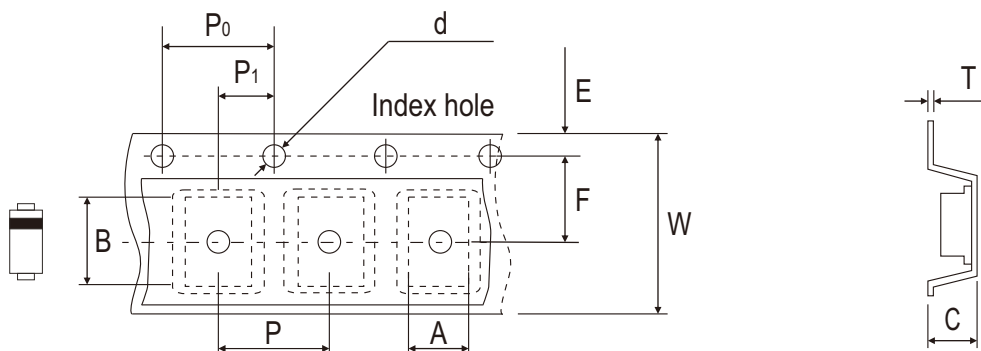

Fig.5 - Typical Junction Capacitance



Reel Taping Specification



DO-214AB (SMC)	SYMBOL	A	B	C	d	D	D1	D2
	(mm)	6.30 MAX.	8.60 MAX.	2.90 MAX.	1.50 ± 0.10	330 ± 2.00	50 MIN.	13.50 ± 1.00
	(inch)	0.248 MAX.	0.339 MAX.	0.114 MAX.	0.059 ± 0.004	12.992 ± 0.079	1.969 MIN.	0.531 ± 0.039

DO-214AB (SMC)	SYMBOL	E	F	P	P0	P1	T	W	W1
	(mm)	1.75 ± 0.10	7.50 ± 0.10	8.00 ± 0.10	4.00 ± 0.10	2.00 ± 0.10	0.6 MAX.	16.00 ± 0.30	22.40 MAX.
	(inch)	0.069 ± 0.004	0.295 ± 0.004	0.315 ± 0.004	0.157 ± 0.004	0.079 ± 0.004	0.024 MAX.	0.630 ± 0.012	0.882 MAX.

Company reserves the right to improve product design, functions and reliability without notice. REV:B

Marking Code

Part Number	Marking Code
ACDBC540-HF	540
ACDBC560-HF	560
ACDBC5100-HF	5100

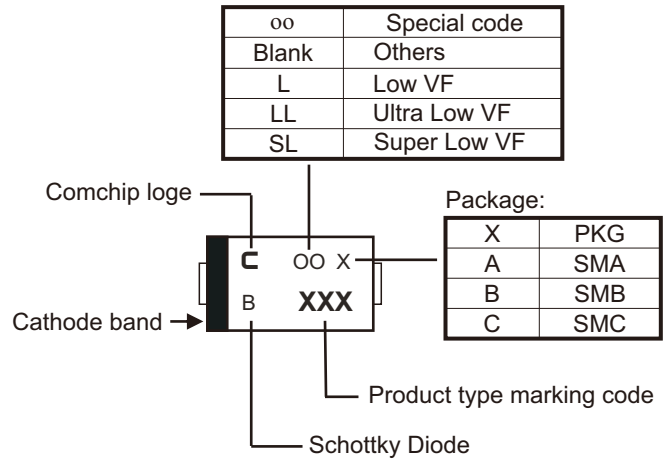

xxx/xxxx = Product type marking code

Suggested PAD Layout

SIZE	DO-214AB (SMC)	
	(mm)	(inch)
A	3.30	0.130
B	2.50	0.098
C	4.40	0.173
D	6.80	0.268
E	9.40	0.370

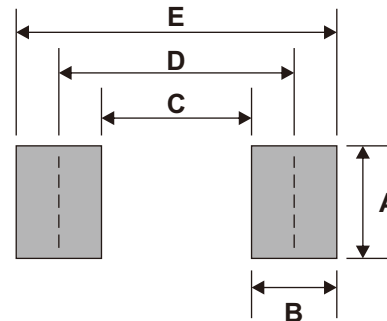

Note: 1. The pad layout is for reference purposes only.

Standard Packaging

Case Type	REEL PACK	
	REEL (pcs)	Reel Size (inch)
DO-214AB (SMC)	3,000	13

X-ON Electronics

Largest Supplier of Electrical and Electronic Components

Click to view similar products for [Schottky Diodes & Rectifiers](#) category:

Click to view products by [Comchip](#) manufacturer:

Other Similar products are found below :

[MA4E2039](#) [MA4E2508M-1112](#) [MBR1545CT](#) [MMBD301M3T5G](#) [RB160M-50TR](#) [D83C](#) [BAS16E6433HTMA1](#) [BAT 54-02LRH E6327](#)
[NRVBAF360T3G](#) [NSR05F40QNXT5G](#) [NTE555](#) [JANS1N6640](#) [SK310-T](#) [SK34B-TP](#) [SS3003CH-TL-E](#) [GA01SHT18](#)
[CRS10I30A\(TE85L,QM](#) [MA4E2501L-1290](#) [MBRA140TRPBF](#) [MBRB30H30CT-1G](#) [BAT 15-04R E6152](#) [JANTX1N5712-1](#) [DMJ3940-000](#)
[SB007-03C-TB-E](#) [SK33B-TP](#) [NRVBB20100CTT4G](#) [NRVBM120LT1G](#) [NTSB30U100CT-1G](#) [VS-6CWQ10FNHM3](#) [CRG04\(T5L,TEMQ\)](#)
[ACDBA1100LR-HF](#) [ACDBA1200-HF](#) [ACDBA240-HF](#) [ACDBA3100-HF](#) [CDBQC0530L-HF](#) [CDBQC0240LR-HF](#) [ACDBA260LR-HF](#)
[ACDBA1100-HF](#) [MA4E2502L-1246](#) [10BQ015-M3/5BT](#) [NRVBM120ET1G](#) [CRS08TE85LQM](#) [PMAD1108-LF](#) [B120Q-13-F](#) [1N5819T-G](#)
[B0530WSQ-7-F](#) [PDS1040Q-13](#) [B160BQ-13-F](#) [SDM05U20CSP-7](#) [B140S1F-7](#)