

ACGRA4001-HF Thru. ACGRA4007-HF

Reverse Voltage: 50 to 1000 Volts

Forward Current: 1.0 Amp

RoHS Device

Halogen Free

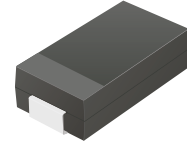

Features

- Glass Passivation Junction.
- High current capability.
- High surge current capability.
- Low reverse current.
- Comply with AEC-Q101

Mechanical data

- Case: DO-214AC / SMA, molded plastic.
- Epoxy: UL flammability classification rate 94V-0.
- Terminals: Lead free plating (Tin finish).
Solderable per MIL-STD-750, Method 2026.
- Polarity: Indicated by cathode band.
- Weight: 0.062 grams(approx.).

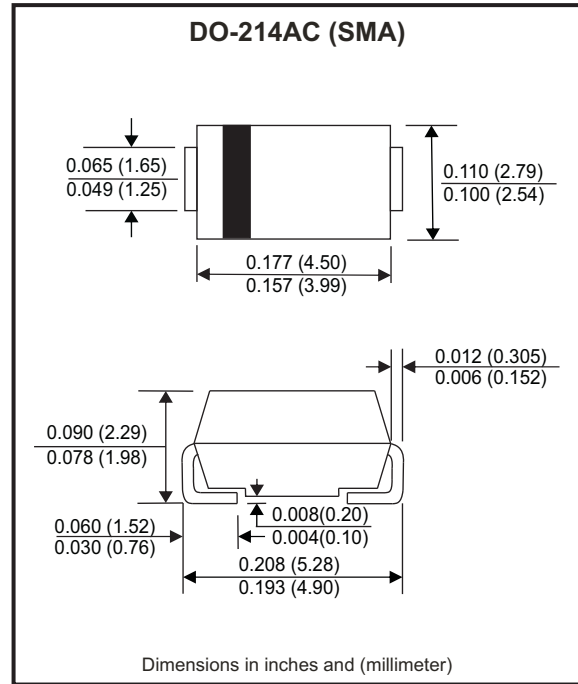

Circuit diagram



Maximum Ratings (at TA=25°C unless otherwise noted)

Parameter	Symbol	ACGRA 4001-HF	ACGRA 4002-HF	ACGRA 4003-HF	ACGRA 4004-HF	ACGRA 4005-HF	ACGRA 4006-HF	ACGRA 4007-HF	Units	
Max. repetitive peak reverse voltage	V _{RRM}	50	100	200	400	600	800	1000	V	
Max. DC blocking voltage	V _{DC}	50	100	200	400	600	800	1000	V	
Max. RMS voltage	V _{RMS}	35	70	140	280	420	560	700	V	
Peak forward surge current, 8.3ms single half sine-wave superimposed on rated load (JEDEC method)	I _{FSM}	30							A	
Max. average forward rectified current	I _F	1.0							A	
Max. instantaneous forward voltage I _F =1.0A @ 25°C	V _F	1.1							V	
Max. DC reverse current at rated	I _R	T _A =25°C	5							μA
DC blocking voltage		T _A =100°C	50							
Typical junction capacitance (Note 1)	C _J	10							pF	
Typical thermal resistance	R _{θJC}	70							°C/W	
Operating temperature range	T _J	-55 to +150							°C	
Storage temperature range	T _{STG}	-55 to +150							°C	

Notes: 1. Measured at 1.0MHZ and applied reverse voltage of 4.0V DC.

Company reserves the right to improve product design , functions and reliability without notice.

REV: B

Rating and Characteristic Curves (ACGRA4001-HF thru. ACGRA4007-HF)

Fig.1 - Typical Forward Current Derating Curve

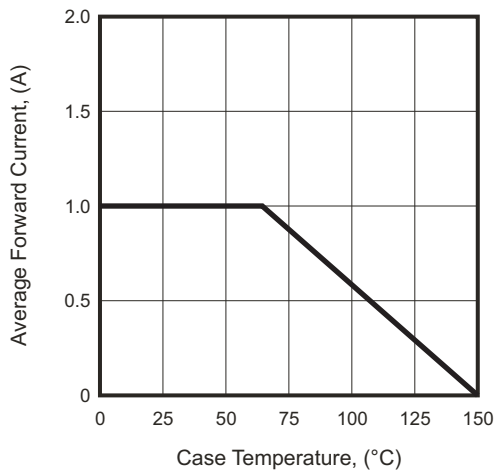

Fig.2 - Typical Forward Characteristics

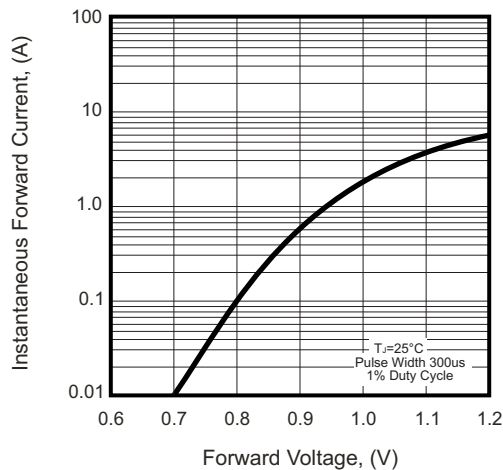

Fig.3 - Maximum Non-repetitive Forward Surge Current

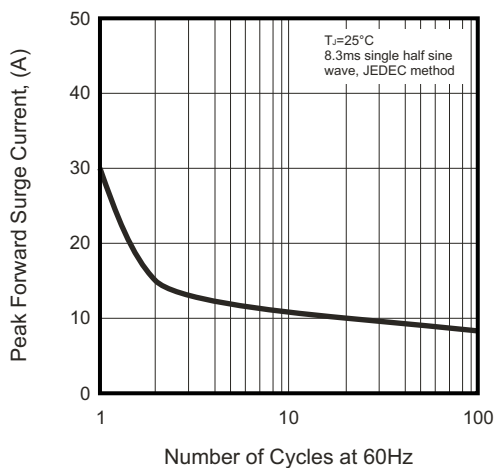

Fig.4 - Typical Reverse Characteristics

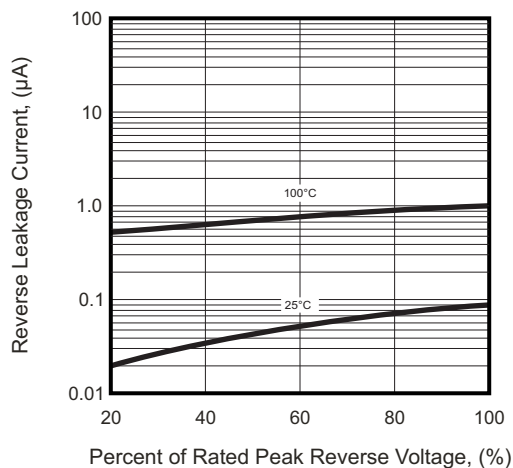
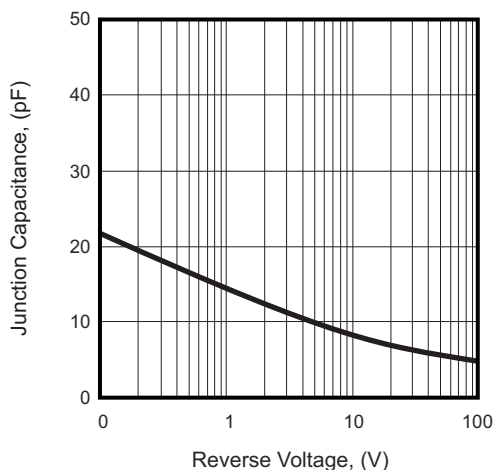

Fig.5 - Typical Junction Capacitance



Company reserves the right to improve product design, functions and reliability without notice.

REV: B

Reel Taping Specification

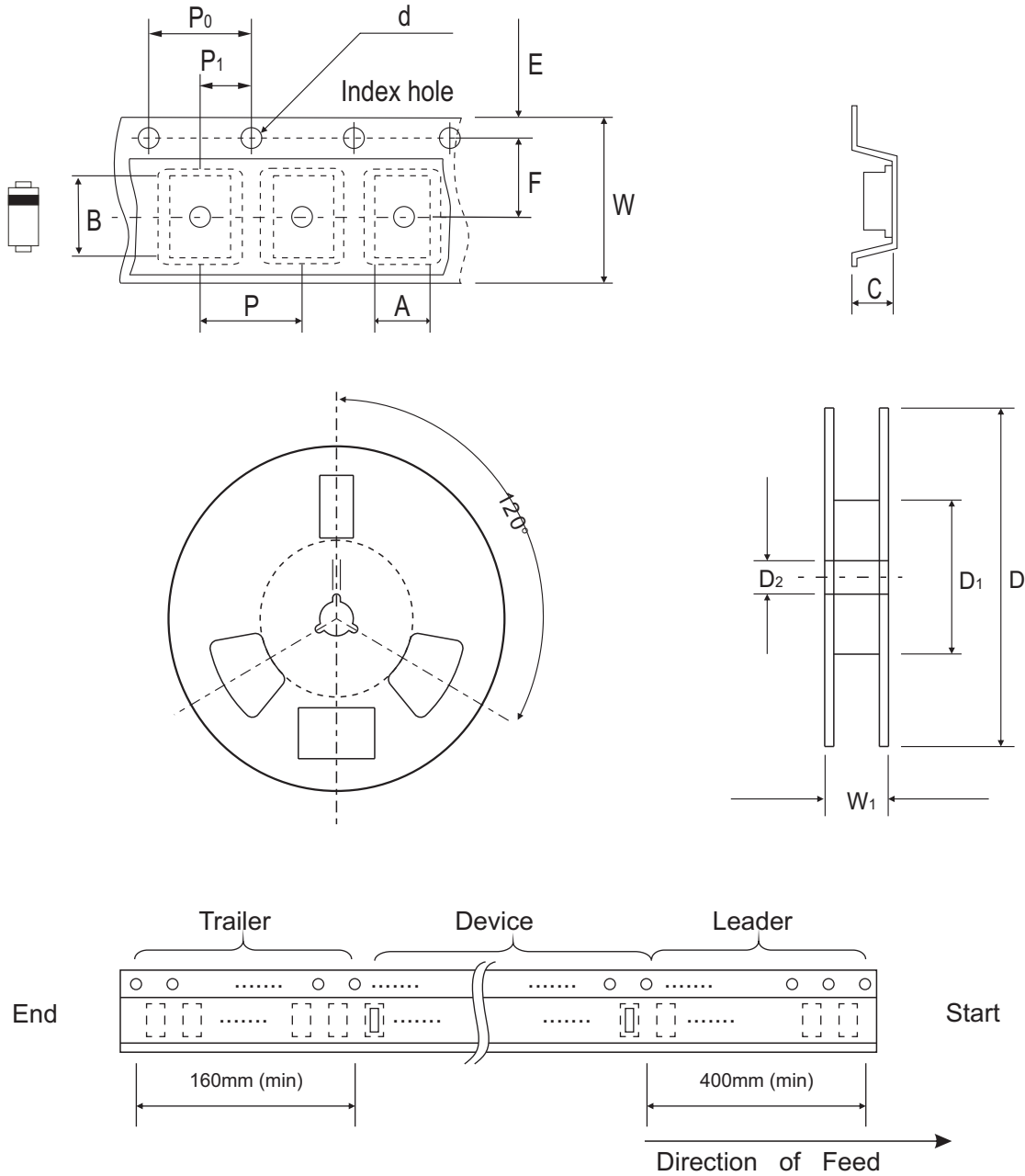

DO-214AC (SMA)	SYMBOL	A	B	C	d	D	D ₁	D ₂
	(mm)	2.90 MAX.	5.90 MAX.	2.66 MAX.	1.50 ± 0.10	330 ± 2.00	50 MIN.	13.50 ± 1.00
	(inch)	0.114 MAX.	0.232 MAX.	0.105 MAX.	0.059 ± 0.004	13.00 ± 0.079	1.969 MIN.	0.531 ± 0.039

DO-214AC (SMA)	SYMBOL	E	F	P	P ₀	P ₁	W	W ₁
	(mm)	1.75 ± 0.10	5.50 ± 0.05	4.00 ± 0.10	4.00 ± 0.10	2.00 ± 0.05	12.00 ± 0.30	18.40 MAX.
	(inch)	0.069 ± 0.004	0.217 ± 0.002	0.157 ± 0.004	0.157 ± 0.004	0.079 ± 0.002	0.472 ± 0.012	0.724 MAX.

Company reserves the right to improve product design, functions and reliability without notice.

REV: B

Marking Code

Part Number	Marking code
ACGRA4001-HF	4001
ACGRA4002-HF	4002
ACGRA4003-HF	4003
ACGRA4004-HF	4004
ACGRA4005-HF	4005
ACGRA4006-HF	4006
ACGRA4007-HF	4007

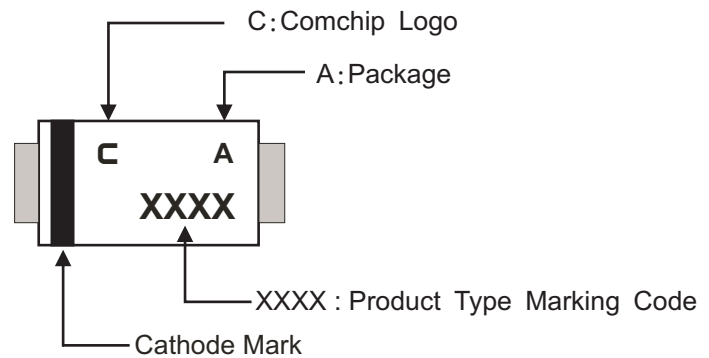

Suggested PAD Layout

SIZE	DO-214AC (SMA)	
	(mm)	(inch)
A	1.70	0.067
B	2.50	0.098
C	1.50	0.059
D	4.00	0.157
E	6.50	0.256

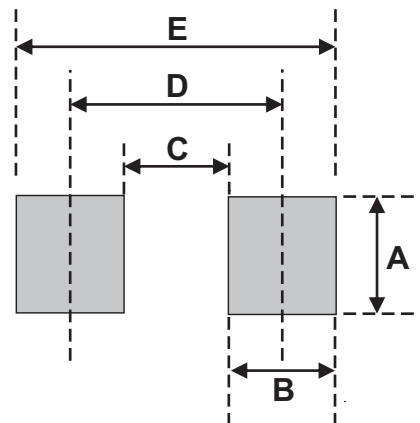

Note:

1. The pad layout is for reference purposes only.

Standard Packaging

Case Type	REEL PACK	
	REEL (pcs)	Reel Size (inch)
DO-214AC (SMA)	5,000	13

X-ON Electronics

Largest Supplier of Electrical and Electronic Components

Click to view similar products for [Diodes - General Purpose, Power, Switching category:](#)

Click to view products by [Comchip manufacturer:](#)

Other Similar products are found below :

[MCL4151-TR3](#) [MMBD3004S-13-F](#) [RD0306T-H](#) [1N3611](#) [NTE156A](#) [NTE574](#) [NTE6244](#) [1SS193,LF](#) [1SS400CST2RA](#) [SDAA13](#)
[SHN2D02FUTW1T1G](#) [LS4151GS08](#) [1N4449](#) [1N456A](#) [1N4934-E3/73](#) [1N914BTR](#) [RFUH20TB3S](#) [D291S45T](#) [BAV300-TR](#) [BAW56DWQ-](#)
[7-F](#) [BAW56M3T5G](#) [BAW75-TAP](#) [MM230L-CAA](#) [IDW40E65D1](#) [JAN1N3600](#) [JAN1N4454UR-1](#) [LL4151-GS18](#) [SMMSD4148T3G](#)
[BYW95B/A52A](#) [NSVDAN222T1G](#) [CDSZC01100-HF](#) [LL4150-M-08](#) [1N4454-TR](#) [BAV70HDW-7](#) [BAS28-7](#) [JANTX1N6640](#) [BAW56HDW-](#)
[13](#) [BAS28 TR](#) [VS-HFA04SD60STR-M3](#) [NSVM1MA152WKT1G](#) [1SS388-TP](#) [RGP30D-E3/73](#) [VS-8EWF02S-M3](#) [BAV99TQ-13-F](#)
[BAV99HDW-13](#) [MMDB30-E28X](#) [IDP20C65D2XKSA1](#) [LS4148](#) [IDV15E65D2](#) [NSVM1MA152WAT1G](#)