

ACGRAT101L-HF Thru. ACGRAT105L-HF

Glass Passivated Type

Reverse Voltage: 200 to 1000 Volts

Forward Current: 1.0 Amp

RoHS Device

Halogen Free



Features

- Glass passivated cavity-free junction.
- Lead less chip form, no lead damage.
- Low forward voltage drop.
- Plastic package has UL 94V-0.
- Comply with AEC-Q101

Mechanical data

- Case: Packed with FRP substrate and epoxy underfilled.
- Terminals: Pure Tin plated, solderable per MIL-STD-750, method 2026.
- Polarity: Cathode Band, Laser marking.
- Weight: 0.02 grams(approx).

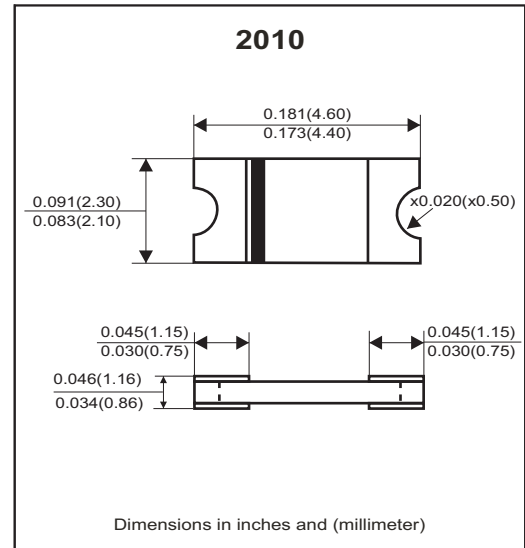

Circuit Diagram



Absolute Maximum Ratings (at Ta=25°C unless otherwise noted)

Parameter	Symbol	ACGRAT 101L-HF	ACGRAT 102L-HF	ACGRAT 103L-HF	ACGRAT 104L-HF	ACGRAT 105L-HF	Units
Repetitive peak reverse voltage	V _{RRM}	200	400	600	800	1000	V
Peak forward surge current, 8.3ms single half sine-wave superimposed on rate load (JEDEC method)	I _{FSM}	40					A
Average forward current	I _{F(AV)}	1.0					A
Operating junction temperature	T _J	-65 to +175					°C
Storage temperature	T _{STG}	-65 to +175					°C

Electrical Characteristics (at TA=25°C unless otherwise noted)

Parameter	Conditions	Symbol	MIN.	TYP.	MAX.	Unit
Forward voltage	I _F = 1.0A	V _F	-	0.91	0.93	V
Repetitive peak reverse current	V _R = Max. V _{RRM} , T _A = 25°C	I _{RRM}	-	0.08	5	uA
Junction capacitance	V _R = 4V, f = 1.0MHz	C _J	-	8.2	-	pF
Thermal Resistance	Junction to ambient (Note)	R _{θJA}	-	70	-	°C/W
	Junction to lead (Note)	R _{θJL}	-	8	-	

Notes: Thermal resistance from junction to ambient and from junction to lead P.C.B. mounted on 0.2×0.2"(5.0*5.0mm) copper pad areas.

Company reserves the right to improve product design, functions and reliability without notice.

REV: B

RATING AND CHARACTERISTIC CURVES (ACGRAT101L-HF thru ACGRAT105L-HF)

FIG.1 - FORWARD CURRENT DERATING CURVE

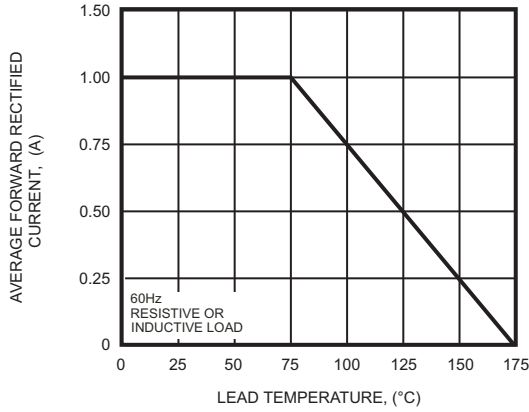

FIG.2 - MAXIMUM NON-REPETITIVE PEAK FORWARD SURGE CURRENT

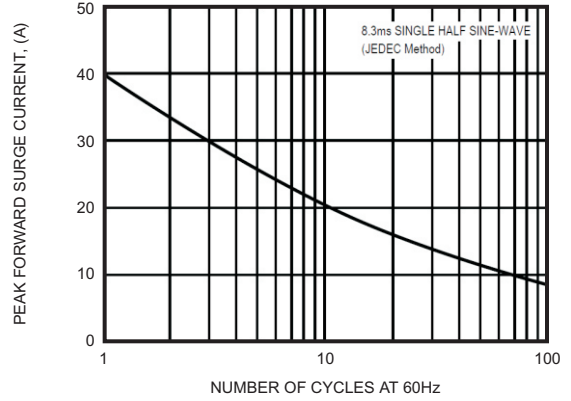

FIG.3 - TYPICAL INSTANTANEOUS FORWARD CHARACTERISTICS

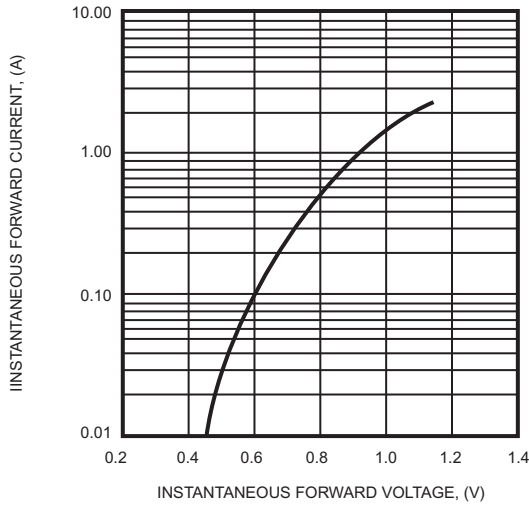

FIG.4 - TYPICAL REVERSE CHARACTERISTICS

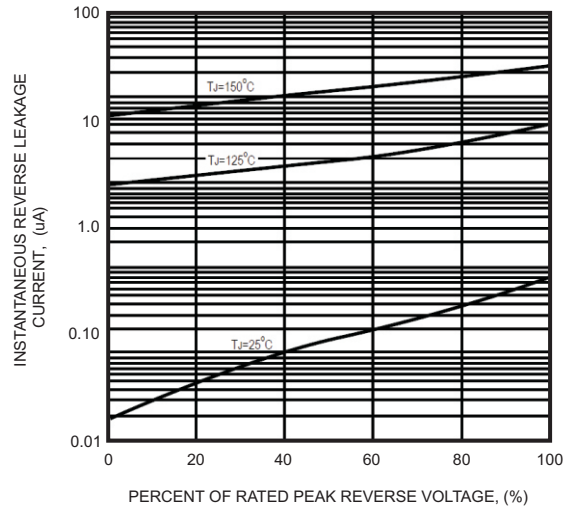
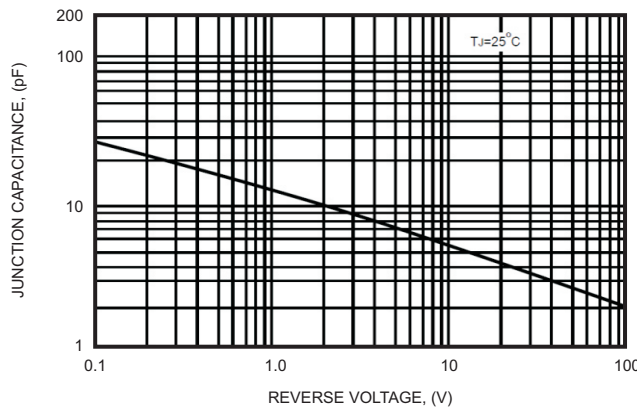
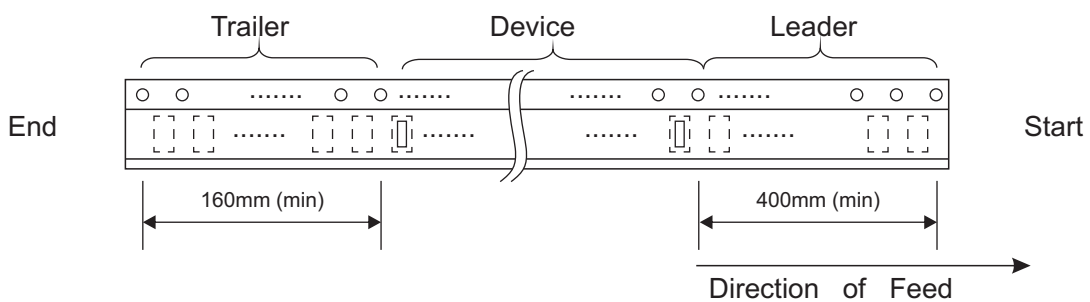
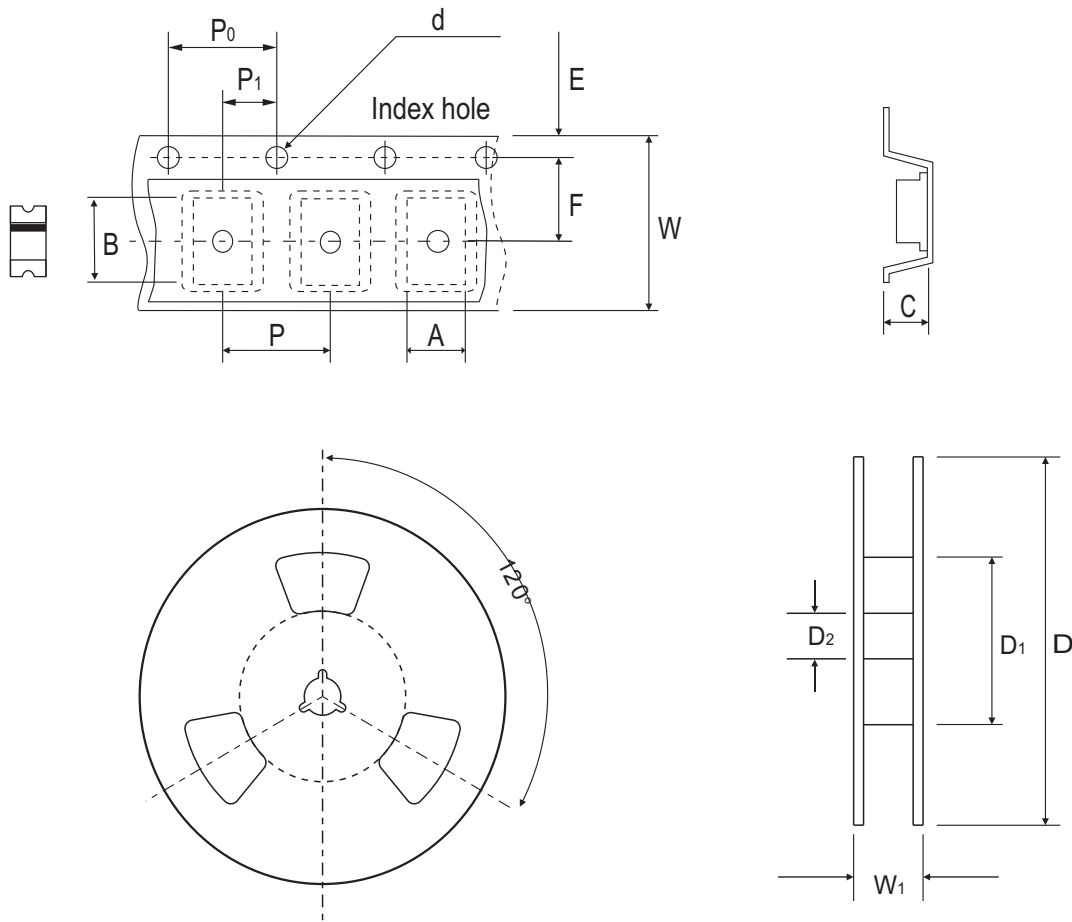

FIG.5 - TYPICAL JUNCTION CAPACITANCE



Reel Taping Specification



2010	SYMBOL	A	B	C	d	D	D ₁	D ₂
	(mm)	4.75 ± 0.10	2.45 ± 0.10	1.30 ± 0.10	1.50 ± 0.10	178.00 ± 2.00	50.00 MIN.	13.00 ± 0.50
	(inch)	0.187 ± 0.004	0.096 ± 0.004	0.051 ± 0.004	0.059 ± 0.004	7.008 ± 0.079	1.969 MIN.	0.512 ± 0.020

2010	SYMBOL	E	F	P	P ₀	P ₁	W	W ₁
	(mm)	1.75 ± 0.10	5.50 ± 0.05	4.00 ± 0.10	4.00 ± 0.10	2.00 ± 0.10	12.00 ± 0.30	18.70 MAX.
	(inch)	0.069 ± 0.004	0.217 ± 0.002	0.157 ± 0.004	0.157 ± 0.004	0.079 ± 0.004	0.472 ± 0.012	0.736 MAX.

Marking Code

Part Number	Marking Code
ACGRAT101L-HF	10D
ACGRAT102L-HF	10G
ACGRAT103L-HF	10J
ACGRAT104L-HF	10K
ACGRAT105L-HF	10M



XXX = Product type marking code

Suggested PAD Layout

SIZE	2010	
	(mm)	(inch)
A	1.47MIN.	0.058MIN.
B	1.27MIN.	0.050MIN.
C	2.60MAX.	0.102MAX.
D	5.14REF.	0.202 REF.

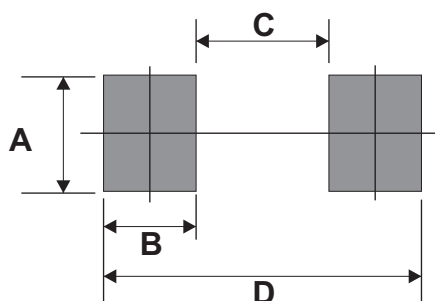

Standard Packaging

Case Type	REEL PACK	
	REEL (pcs)	Reel Size (inch)
2010	3,000	7

X-ON Electronics

Largest Supplier of Electrical and Electronic Components

Click to view similar products for [Rectifiers](#) category:

Click to view products by [Comchip](#) manufacturer:

Other Similar products are found below :

[70HFR40](#) [RL252-TP](#) [150KR30A](#) [1N5397](#) [NTE5841](#) [NTE6038](#) [SCF5000](#) [1N4002G](#) [1N4005-TR](#) [JANS1N6640US](#) [VS-80-7161](#) [481235F](#)
[RRE02VS6SGTR](#) [067907F](#) [MS306](#) [70HF40](#) [T85HFL60S02](#) [US2JFL-TP](#) [A1N5404G-G](#) [CRS04\(T5L,TEMQ\)](#) [ACGRA4007-HF](#)
[ACGRB207-HF](#) [CLH03\(TE16L,Q\)](#) [ACGRC307-HF](#) [ACEFC304-HF](#) [NTE6356](#) [NTE6359](#) [NTE6002](#) [NTE6023](#) [NTE6039](#) [NTE6077](#)
[85HFR60](#) [40HFR60](#) [1N1186RA](#) [70HF120](#) [85HFR80](#) [D126A45C](#) [SCF7500](#) [D251N08B](#) [SCHJ22.5K](#) [SM100](#) [SCPA2](#) [SCH10000](#) [SDHD5K](#)
[VS-12FL100S10](#) [ACGRA4001-HF](#) [D1821SH45T PR](#) [D1251S45T](#) [NTE5990](#) [NTE6358](#)