

ACGRB201-HF Thru. ACGRB207-HF

Reverse Voltage: 50 to 1000 Volts

Forward Current: 2.0 Amp

RoHS Device

Halogen Free

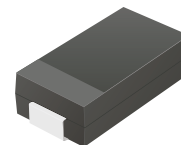

Features

- Glass passivation junction.
- High current capability.
- High surge current capability.
- Low reverse current.
- Comply with AEC-Q101

Mechanical data

- Case: DO-214AA / SMB, molded plastic.
- Epoxy: UL flammability classification rate 94V-0.
- Terminals: Lead free plating (Tin finish).
Solderable per MIL-STD-202, Method 208.
- Polarity: Cathode band.
- Weight: 0.092 grams(approx.).

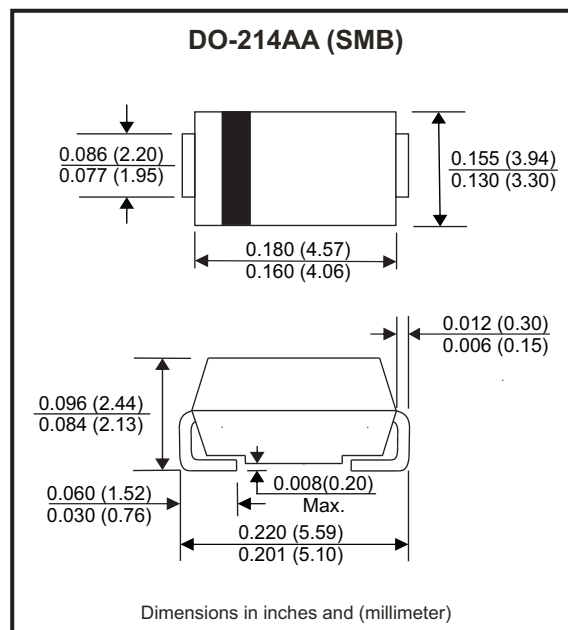

Circuit diagram



Maximum Ratings (at TA=25°C unless otherwise noted)

Parameter	Symbol	ACGRB 201-HF	ACGRB 202-HF	ACGRB 203-HF	ACGRB 204-HF	ACGRB 205-HF	ACGRB 206-HF	ACGRB 207-HF	Units
Max. repetitive peak reverse voltage	V_{RRM}	50	100	200	400	600	800	1000	V
Max. DC blocking voltage	V_{DC}	50	100	200	400	600	800	1000	V
Max. RMS voltage	V_{RMS}	35	70	140	280	420	560	700	V
Peak forward surge current, 8.3ms single half sine-wave superimposed on rated load (JEDEC method)	I_{FSM}	60							A
Max. average forward rectified current	I_F	2.0							A
Max. instantaneous forward voltage $I_F=2.0A @ 25^\circ C$	V_F	1.1							V
Max. DC reverse current at rated	I_R	5							μA
DC blocking voltage	I_R	100							
Typical junction capacitance (Note 1)	C_J	10							pF
Typical thermal resistance	$R_{\theta JC}$	40							$^\circ C/W$
Operating temperature range	T_J	-55 to +150							$^\circ C$
Storage temperature range	T_{STG}	-55 to +150							$^\circ C$

Notes: 1. Measured at 1.0MHZ and applied reverse voltage of 4.0V DC.

Company reserves the right to improve product design , functions and reliability without notice.

REV: B

Rating and Characteristic Curves (ACGRB201-HF Thru. ACGRB207-HF)

Fig.1 - Typical Forward Current Derating Curve

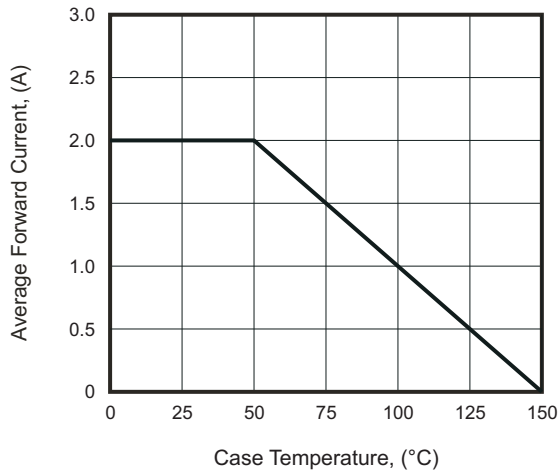

Fig.2 - Typical Forward Characteristics

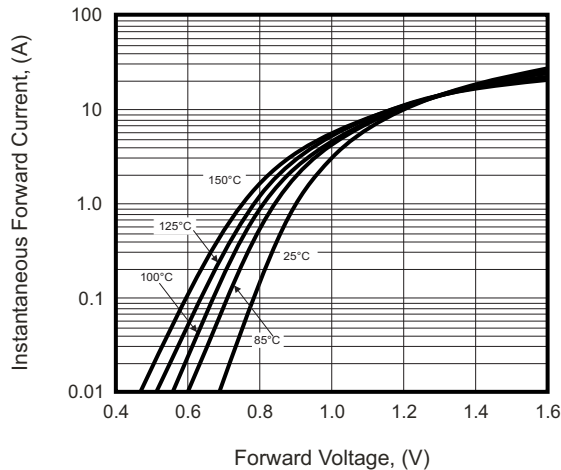

Fig.3 - Maximum Non-Repetitive Forward Surge Current

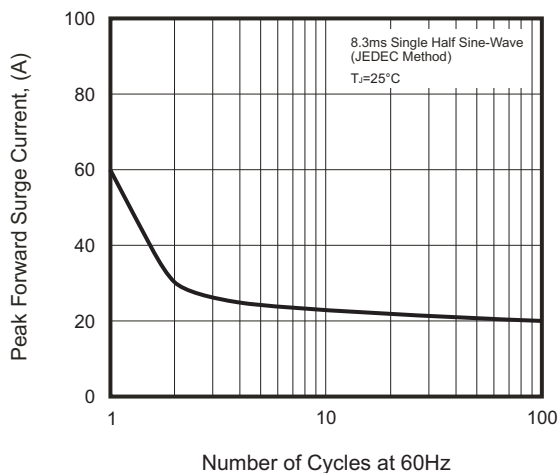

Fig.4 - Typical Reverse Characteristics

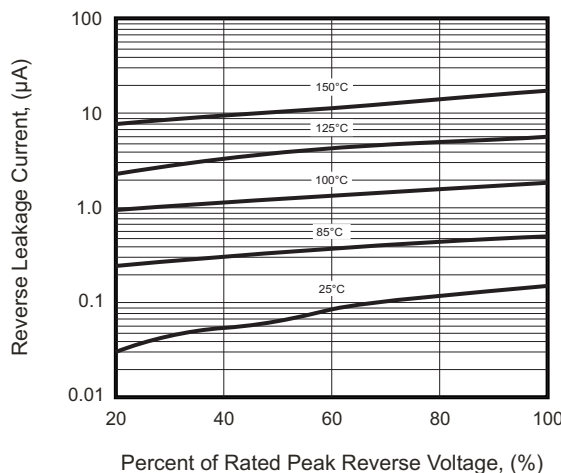
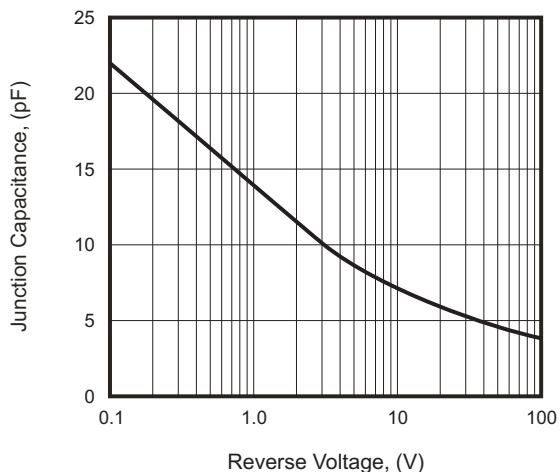

Fig.5 - Typical Junction Capacitance



Company reserves the right to improve product design, functions and reliability without notice.

REV: B

Reel Taping Specification

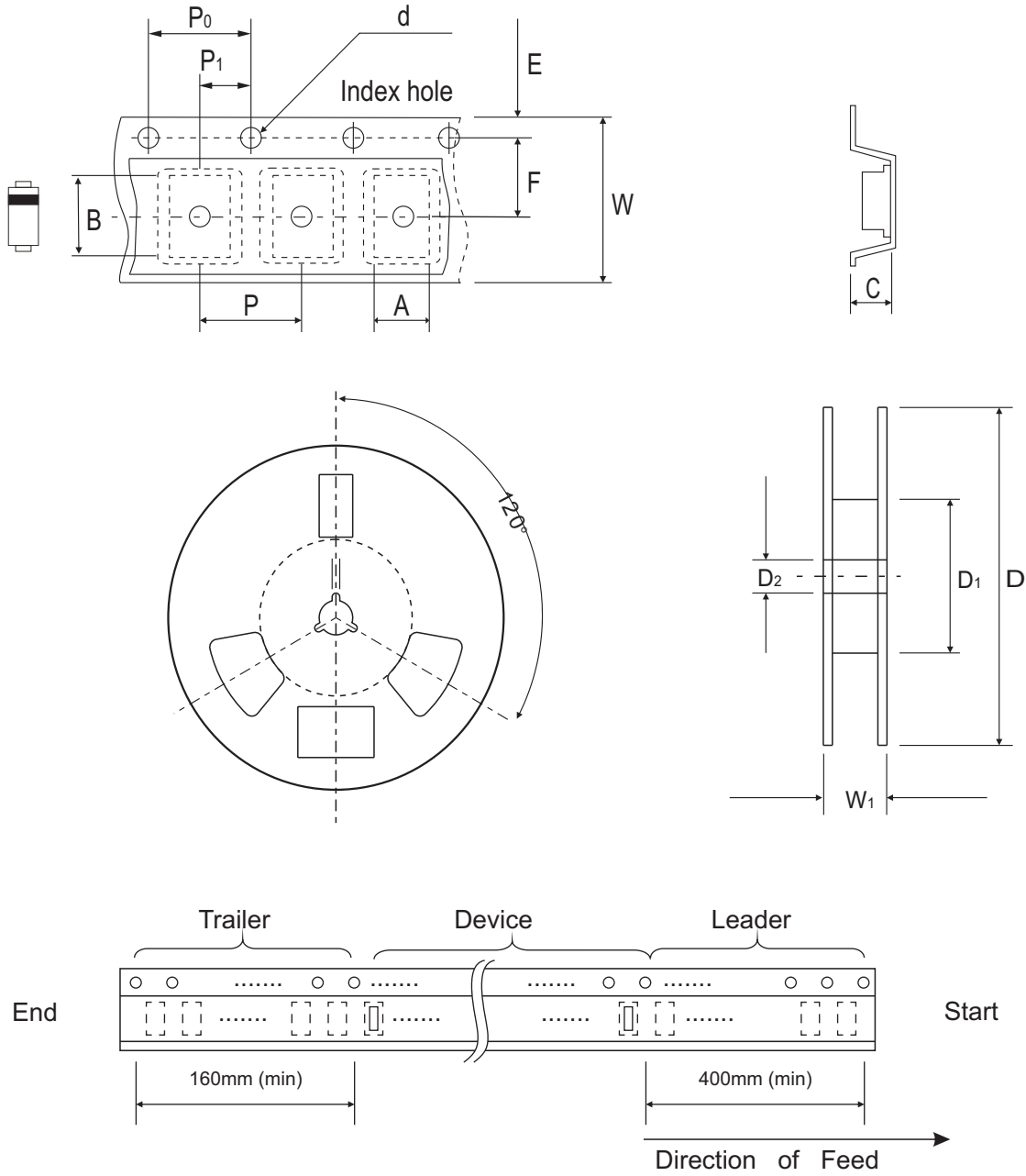

DO-214AA (SMB)	SYMBOL	A	B	C	d	D	D ₁	D ₂
	(mm)	4.00 MAX.	5.90 MAX.	3.00 MAX.	1.50 ± 0.10	330 ± 2.00	50 MIN.	13.50 ± 1.00
	(inch)	0.157 MAX.	0.232 MAX.	0.118 MAX.	0.059 ± 0.004	13.00 ± 0.079	1.969 MIN.	0.531 ± 0.039

DO-214AA (SMB)	SYMBOL	E	F	P	P ₀	P ₁	W	W ₁
	(mm)	1.75 ± 0.10	5.50 ± 0.05	8.00 ± 0.10	4.00 ± 0.10	2.00 ± 0.05	12.00 ± 0.30	18.40 MAX.
	(inch)	0.069 ± 0.004	0.217 ± 0.002	0.315 ± 0.004	0.157 ± 0.004	0.079 ± 0.002	0.472 ± 0.012	0.724 MAX.

Company reserves the right to improve product design, functions and reliability without notice.

REV: B

Marking Code

Part Number	Marking code
ACGRB201-HF	201
ACGRB202-HF	202
ACGRB203-HF	203
ACGRB204-HF	204
ACGRB205-HF	205
ACGRB206-HF	206
ACGRB207-HF	207

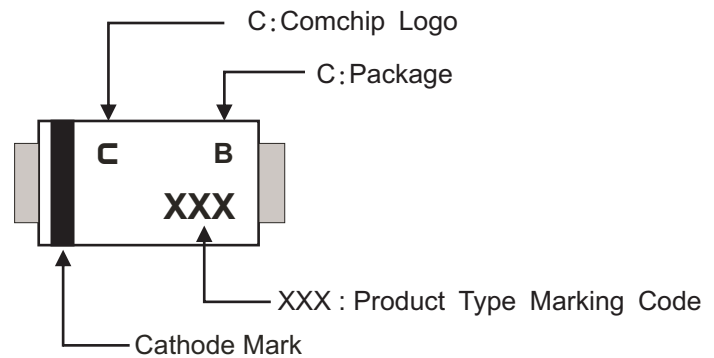

Suggested PAD Layout

SIZE	DO-214AA (SMB)	
	(mm)	(inch)
A	2.30	0.091
B	2.50	0.098
C	1.80	0.071
D	4.30	0.169
E	6.80	0.268

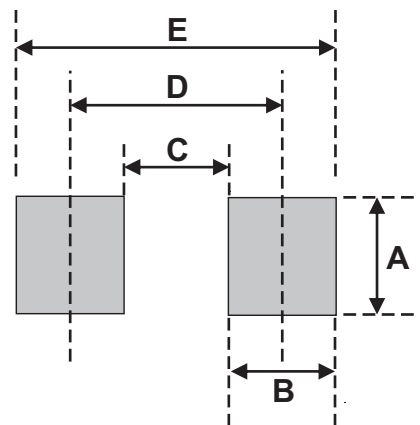

Note:

1. The pad layout is for reference purposes only.

Standard Packaging

Case Type	REEL PACK	
	REEL (pcs)	Reel Size (inch)
DO-214AA (SMB)	3,000	13

X-ON Electronics

Largest Supplier of Electrical and Electronic Components

Click to view similar products for [Rectifiers](#) category:

Click to view products by [Comchip](#) manufacturer:

Other Similar products are found below :

[70HFR40](#) [RL252-TP](#) [150KR30A](#) [1N5397](#) [NTE5841](#) [NTE6038](#) [SCF5000](#) [1N4002G](#) [1N4005-TR](#) [JANS1N6640US](#) [481235F](#)

[RRE02VS6SGTR](#) [067907F](#) [MS306](#) [70HF40](#) [T110HF60](#) [T85HFL60S02](#) [US2JFL-TP](#) [A1N5404G-G](#) [CRS04\(T5L,TEMQ\)](#) [ACGRA4007-HF](#)

[ACGRB207-HF](#) [CLH03\(TE16L,Q\)](#) [ACGRC307-HF](#) [ACEFC304-HF](#) [NTE6356](#) [NTE6359](#) [NTE6002](#) [NTE6023](#) [NTE6039](#) [NTE6077](#)

[85HFR60](#) [40HFR60](#) [1N1186RA](#) [70HF120](#) [85HFR80](#) [D126A45C](#) [SCF7500](#) [D251N08B](#) [SCHJ22.5K](#) [SM100](#) [SCPA2](#) [SCH10000](#) [SDHD5K](#)

[VS-12FL100S10](#) [ACGRA4001-HF](#) [D1821SH45T PR](#) [D1251S45T](#) [NTE5990](#) [NTE6358](#)