

## ATV02W5V0-HF Thru ATV02W191-HF

**Working Peak Reverse Voltage:5.0-190 Volts**

**Peak Pulse Power:200 Watts**

**RoHS Device**

**Halogen Free**

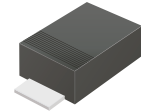

### Features

- Glass passivated chip.
- Low leakage current.
- 200W peak pulse power capability with a 10/1000 $\mu$ s waveform, repetitive rate (duty cycle):0.01%.
- Uni and bidirectional unit.
- Excellent clamping capability.
- Very fast response time.
- Comply with AEC-Q101

### Mechanical data

- Case: Molded plastic.
- Epoxy: UL 94V-0 rate flame retardant.
- Lead: Solderable per MIL-STD-750, method 2026.
- Polarity: Color band denotes cathode end except bipolar.
- Mounting position: Any.
- Weight: 0.016 grams(approx).

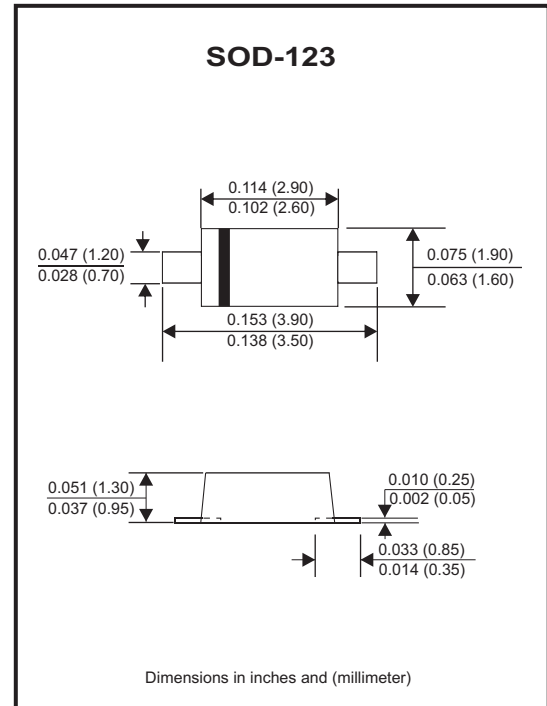

### Circuit Diagram

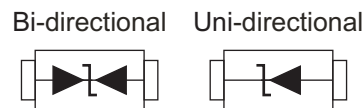

### Maximum Rating and Electrical Characteristics

Ratings at 25°C ambient temperature unless otherwise specified.  
 Single phase, half wave, 60Hz, resistive or inductive load.  
 For capacitive load, derate current by 20%.

| Parameter  | Symbol                           | Value            | Unit |      |
|--|----------------------------------|------------------|------|------|
| Peak power dissipation at 10/1000 $\mu$ s waveform (Note 1)                          | PPP                              | 200              | W    |      |
| Peak power dissipation at 8/20 $\mu$ s waveform (Note 1)                             | PPP                              | 1000             | W    |      |
| Peak pulse current with a 10/1000 $\mu$ s waveform (Note 1)                          | IPP                              | See next table   | A    |      |
| Power dissipation on infinite heatsink at T <sub>L</sub> = 75°C                      | PD                               | 0.4              | W    |      |
| Peak forward surge current, 8.3ms single half sine-wave unidirectional only (Note 2) | IFSM                             | 20               | A    |      |
| Max.instantaneous forward voltage at 25A for unidirectional only                     | V <sub>F</sub>                   | 3.5              | V    |      |
| Typical thermal resistance (Note 3)  | Junction to ambient              | R <sub>θJA</sub> | 200  | °C/W |
|  | Junction to case                 | R <sub>θJC</sub> | 100  |      |
| Operating junction and storage temperature range                                     | T <sub>J</sub> ,T <sub>STG</sub> | -55 to +150      | °C   |      |

Notes: 1. Non-repetitive current pulse, per Fig.3 and derated above T<sub>A</sub>=25°C per Fig.1  
 2. Measured on 8.3ms single half sine-wave or equivalent square wave, duty cycle=4 pulses per minute maximum.  
 3. Thermal resistance from junction to ambient and from junction to case, mounted on 10x10mm copper pad areas.

## Rating and Characteristic Curves (ATV02W5V0-HF Thru. ATV02W191-HF)

Fig. 1 - Pulse Derating Curve

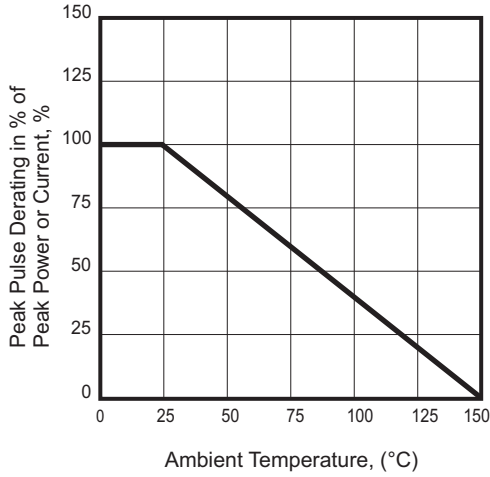

Fig.2 - Steady State Power Derating Curve

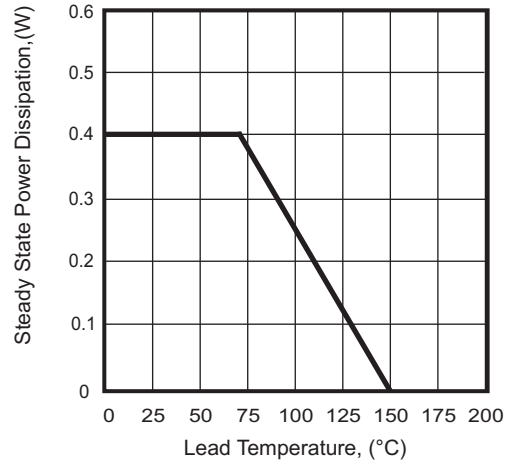

Fig. 3 - Pulse Waveform

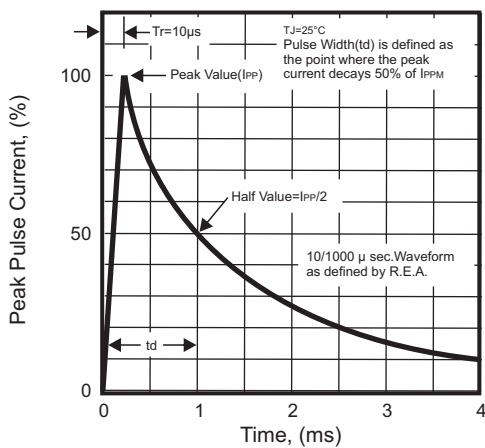

Fig. 4 - Peak Pulse Power Rating Curve

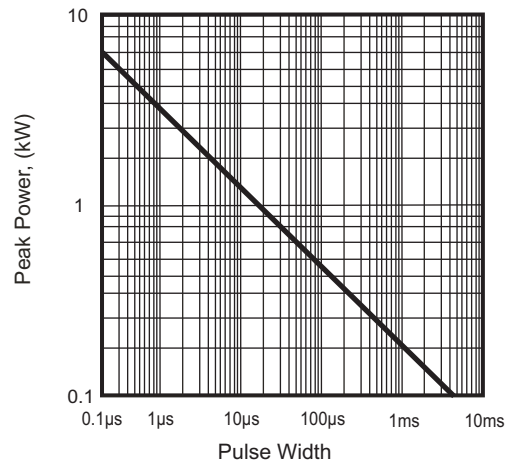

Fig. 5 - Maximum non-repetitive surge current

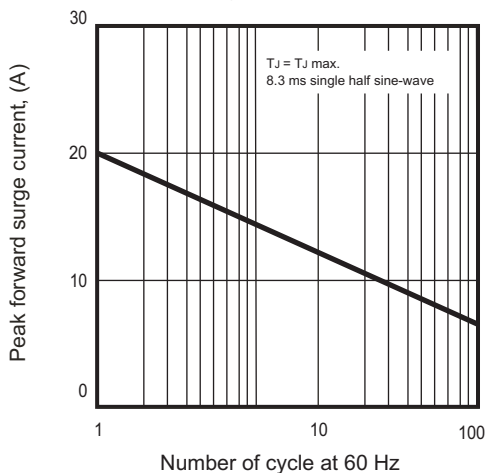
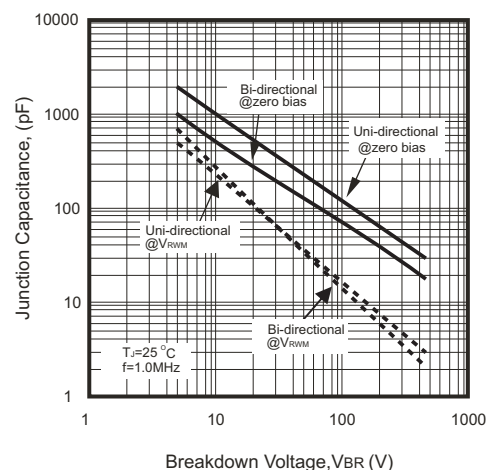

Fig.6 - Typical Junction Capacitance



# SMD Transient Voltage Suppressor

## Electrical Characteristics (ATV02W5V0-HF Thru. ATV02W191-HF)

| Part No         | Absolute Maximum Rating (Ta=25°C) |                      |                      |                | V <sub>C</sub> (Max.)<br>@ IPP | IPP<br>@ 10/1000us | I <sub>R</sub><br>@ V <sub>RWM</sub> | Marking Code |    |
|-----------------|-----------------------------------|----------------------|----------------------|----------------|--------------------------------|--------------------|--------------------------------------|--------------|----|
|                 | V <sub>RWM</sub>                  | V <sub>BR</sub> Min. | V <sub>BR</sub> Max. | I <sub>T</sub> |                                |                    |                                      | Uni          | Bi |
|                 | (V)                               | (V)                  | (V)                  | (mA)           | (V)                            | (A)                | (uA)                                 |              |    |
| ATV02W5V0(B)-HF | 5.0                               | 6.40                 | 7.00                 | 10             | 9.20                           | 21.74              | 400                                  | FE           | KE |
| ATV02W6V0(B)-HF | 6.0                               | 6.67                 | 7.37                 | 10             | 10.3                           | 19.42              | 400                                  | FG           | KG |
| ATV02W6V5(B)-HF | 6.5                               | 7.22                 | 7.98                 | 10             | 11.2                           | 17.86              | 250                                  | FK           | KK |
| ATV02W7V0(B)-HF | 7.0                               | 7.78                 | 8.60                 | 10             | 12.0                           | 16.67              | 100                                  | FM           | KM |
| ATV02W7V5(B)-HF | 7.5                               | 8.33                 | 9.21                 | 1              | 12.9                           | 15.50              | 50                                   | FP           | KP |
| ATV02W8V0(B)-HF | 8.0                               | 8.89                 | 9.83                 | 1              | 13.6                           | 14.71              | 25                                   | FR           | KR |
| ATV02W8V5(B)-HF | 8.5                               | 9.44                 | 10.40                | 1              | 14.4                           | 13.89              | 10                                   | FT           | KT |
| ATV02W9V0(B)-HF | 9.0                               | 10.00                | 11.10                | 1              | 15.4                           | 12.99              | 5                                    | FV           | KV |
| ATV02W100(B)-HF | 10.0                              | 11.10                | 12.30                | 1              | 17.0                           | 11.76              | 2.5                                  | FX           | KX |
| ATV02W110(B)-HF | 11.0                              | 12.20                | 13.50                | 1              | 18.2                           | 10.99              | 2.5                                  | FZ           | KZ |
| ATV02W120(B)-HF | 12.0                              | 13.30                | 14.70                | 1              | 19.9                           | 10.05              | 2.5                                  | HE           | LE |
| ATV02W130(B)-HF | 13.0                              | 14.40                | 15.90                | 1              | 21.5                           | 9.30               | 1                                    | HG           | LG |
| ATV02W140(B)-HF | 14.0                              | 15.60                | 17.20                | 1              | 23.2                           | 8.62               | 1                                    | HK           | LK |
| ATV02W150(B)-HF | 15.0                              | 16.70                | 18.50                | 1              | 24.4                           | 8.20               | 1                                    | HM           | LM |
| ATV02W160(B)-HF | 16.0                              | 17.80                | 19.70                | 1              | 26.0                           | 7.69               | 1                                    | HP           | LP |
| ATV02W170(B)-HF | 17.0                              | 18.90                | 20.90                | 1              | 27.6                           | 7.25               | 1                                    | HR           | LR |
| ATV02W180(B)-HF | 18.0                              | 20.00                | 22.10                | 1              | 29.2                           | 6.85               | 1                                    | HT           | LT |
| ATV02W190(B)-HF | 19.0                              | 21.10                | 23.30                | 1              | 30.6                           | 6.54               | 1                                    | HB           | LB |
| ATV02W200(B)-HF | 20.0                              | 22.20                | 24.50                | 1              | 32.4                           | 6.17               | 1                                    | HV           | LV |
| ATV02W220(B)-HF | 22.0                              | 24.4                 | 26.90                | 1              | 35.5                           | 5.63               | 1                                    | HX           | LX |
| ATV02W240(B)-HF | 24.0                              | 26.70                | 29.50                | 1              | 38.9                           | 5.14               | 1                                    | HZ           | LZ |
| ATV02W260(B)-HF | 26.0                              | 28.90                | 31.90                | 1              | 42.1                           | 4.75               | 1                                    | JE           | ME |
| ATV02W280(B)-HF | 28.0                              | 31.10                | 34.40                | 1              | 45.4                           | 4.41               | 1                                    | JG           | MG |
| ATV02W300(B)-HF | 30.0                              | 33.30                | 36.80                | 1              | 48.4                           | 4.13               | 1                                    | JK           | MK |
| ATV02W330(B)-HF | 33.0                              | 36.70                | 40.60                | 1              | 53.3                           | 3.75               | 1                                    | JM           | MM |
| ATV02W360(B)-HF | 36.0                              | 40.00                | 44.20                | 1              | 58.1                           | 3.44               | 1                                    | JP           | MP |
| ATV02W400(B)-HF | 40.0                              | 44.40                | 49.10                | 1              | 64.5                           | 3.10               | 1                                    | JR           | MR |
| ATV02W430(B)-HF | 43.0                              | 47.80                | 52.80                | 1              | 69.4                           | 2.88               | 1                                    | JT           | MT |
| ATV02W450(B)-HF | 45.0                              | 50.00                | 55.30                | 1              | 72.7                           | 2.75               | 1                                    | JV           | MV |
| ATV02W480(B)-HF | 48.0                              | 53.30                | 58.90                | 1              | 77.4                           | 2.58               | 1                                    | JX           | MX |
| ATV02W510(B)-HF | 51.0                              | 56.70                | 62.70                | 1              | 82.4                           | 2.43               | 1                                    | JZ           | MZ |
| ATV02W540(B)-HF | 54.0                              | 60.00                | 66.30                | 1              | 87.1                           | 2.30               | 1                                    | XE           | NE |
| ATV02W580(B)-HF | 58.0                              | 64.40                | 71.20                | 1              | 93.6                           | 2.14               | 1                                    | XG           | NG |
| ATV02W600(B)-HF | 60.0                              | 66.70                | 73.70                | 1              | 96.8                           | 2.07               | 1                                    | XK           | NK |
| ATV02W640(B)-HF | 64.0                              | 71.10                | 78.60                | 1              | 103.0                          | 1.94               | 1                                    | XM           | NM |
| ATV02W700(B)-HF | 70.0                              | 77.80                | 86.00                | 1              | 113.0                          | 1.77               | 1                                    | XP           | NP |
| ATV02W750(B)-HF | 75.0                              | 83.30                | 92.10                | 1              | 121.0                          | 1.65               | 1                                    | XR           | NR |
| ATV02W780(B)-HF | 78.0                              | 86.70                | 95.80                | 1              | 126.0                          | 1.59               | 1                                    | XT           | NT |
| ATV02W800(B)-HF | 80.0                              | 88.80                | 97.60                | 1              | 129.0                          | 1.55               | 1                                    | XB           | NB |
| ATV02W850(B)-HF | 85.0                              | 94.40                | 104.00               | 1              | 137.0                          | 1.46               | 1                                    | XV           | NV |
| ATV02W900(B)-HF | 90.0                              | 100.00               | 111.00               | 1              | 146.0                          | 1.37               | 1                                    | XX           | NX |
| ATV02W101(B)-HF | 100.0                             | 111.00               | 123.00               | 1              | 162.0                          | 1.23               | 1                                    | XZ           | NZ |
| ATV02W111(B)-HF | 110.0                             | 122.00               | 135.00               | 1              | 177.0                          | 1.13               | 1                                    | TE           | PE |
| ATV02W121(B)-HF | 120.0                             | 133.00               | 147.00               | 1              | 193.0                          | 1.04               | 1                                    | TG           | PG |
| ATV02W131(B)-HF | 130.0                             | 144.00               | 159.00               | 1              | 209.0                          | 0.96               | 1                                    | TK           | PK |
| ATV02W141(B)-HF | 140.0                             | 155.00               | 171.00               | 1              | 224.0                          | 0.89               | 1                                    | TB           | PB |
| ATV02W151(B)-HF | 150.0                             | 167.00               | 185.00               | 1              | 243.0                          | 0.82               | 1                                    | TM           | PM |
| ATV02W161(B)-HF | 160.0                             | 178.00               | 197.00               | 1              | 259.0                          | 0.77               | 1                                    | TP           | PP |
| ATV02W171(B)-HF | 170.0                             | 189.00               | 209.00               | 1              | 275.0                          | 0.73               | 1                                    | TR           | PR |
| ATV02W181(B)-HF | 180.0                             | 200.00               | 220.00               | 1              | 292.0                          | 0.68               | 1                                    | TT           | PT |
| ATV02W191(B)-HF | 190.0                             | 211.00               | 232.00               | 1              | 308.0                          | 0.65               | 1                                    | TV           | PV |

Notes:

1. Suffix B after part number to specify bi-directional devices.
2. For Bi-Directional devices having V<sub>R</sub> of 10 volts and under, the I<sub>R</sub> limit is double.

Company reserves the right to improve product design , functions and reliability without notice.

REV: C

## Reel Taping Specification

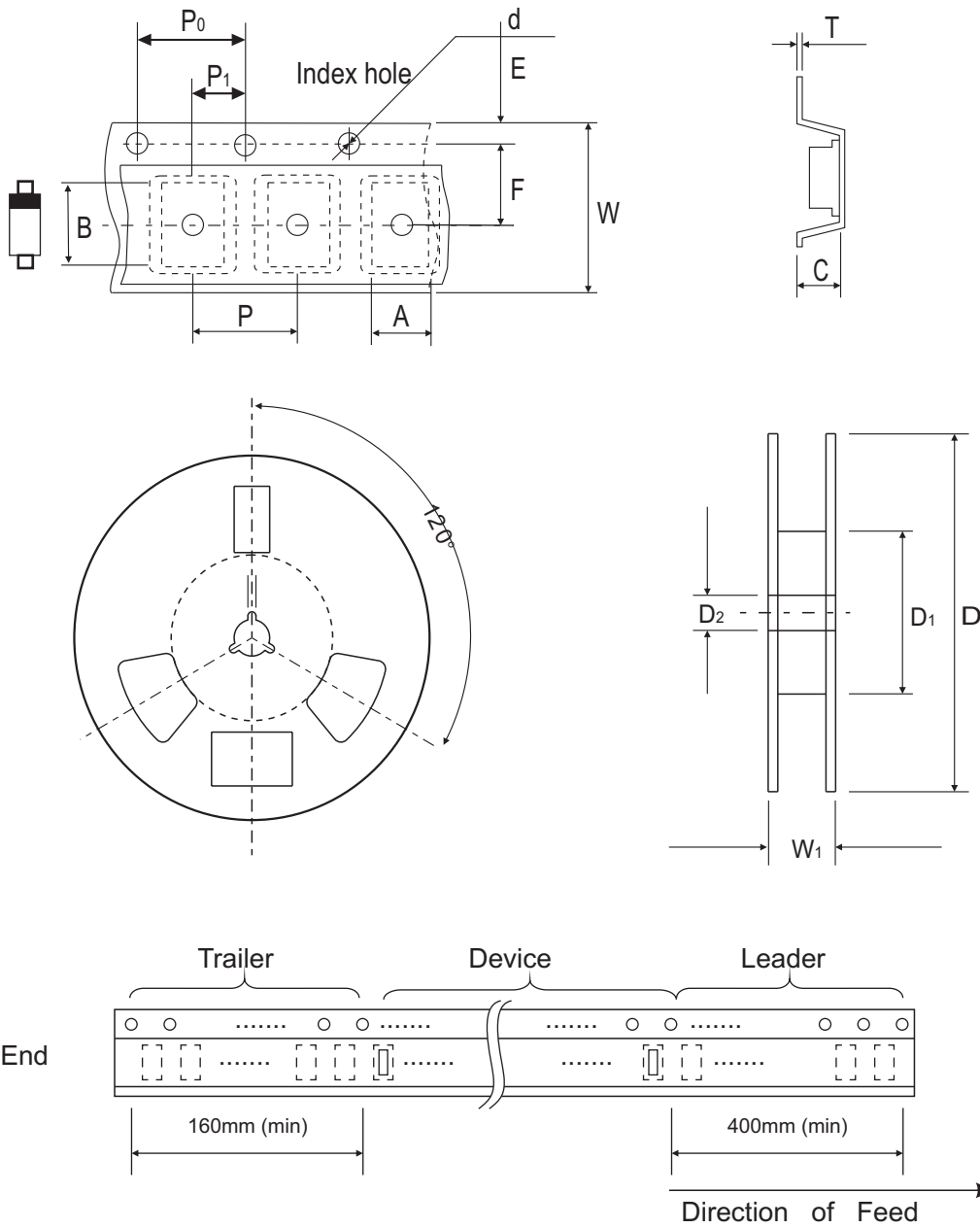

| SOD-123 | SYMBOL | A             | B             | C             | d             | D             | D1         | D2            |
|---------|--------|---------------|---------------|---------------|---------------|---------------|------------|---------------|
|         | (mm)   | 1.85 ± 0.10   | 3.94 ± 0.10   | 1.57 ± 0.10   | 1.55 ± 0.05   | 178.00 ± 1.00 | 50.00 Min. | 13.00 ± 0.20  |
|         | (inch) | 0.073 ± 0.004 | 0.155 ± 0.004 | 0.062 ± 0.004 | 0.061 ± 0.002 | 7.008 ± 0.039 | 1.969 Min. | 0.512 ± 0.008 |

| SOD-123 | SYMBOL | E             | F             | P             | P0            | P1            | W             | W1         |
|---------|--------|---------------|---------------|---------------|---------------|---------------|---------------|------------|
|         | (mm)   | 1.75 ± 0.10   | 3.50 ± 0.05   | 4.00 ± 0.10   | 4.00 ± 0.10   | 2.00 ± 0.05   | 8.00 ± 0.10   | 11.40 Max. |
|         | (inch) | 0.069 ± 0.004 | 0.138 ± 0.002 | 0.157 ± 0.004 | 0.157 ± 0.004 | 0.079 ± 0.002 | 0.315 ± 0.004 | 0.449 Max. |

## Suggested PAD Layout

| SIZE | SOD-123 |        |
|------|---------|--------|
|      | (mm)    | (inch) |
| A    | 2.90    | 0.114  |
| B    | 1.30    | 0.051  |
| C    | 1.40    | 0.055  |
| D    | 4.20    | 0.165  |
| E    | 1.60    | 0.063  |

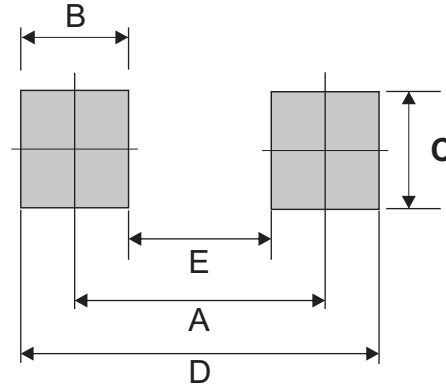

## Standard Packaging

| Case Type | REEL PACK       |                     |
|-----------|-----------------|---------------------|
|           | REEL<br>( pcs ) | Reel Size<br>(inch) |
| SOD-123   | 3,000           | 7                   |

## X-ON Electronics

Largest Supplier of Electrical and Electronic Components

*Click to view similar products for [Comchip manufacturer](#):*

Other Similar products are found below :

[CDBB260-G](#) [CPDA10R5V0P-HF](#) [CDBA340L-HF](#) [ACGRC307-HF](#) [1N5819T-G](#) [P6KE550CA-HF](#) [CDBM140-HF](#) [CDBMT1100-HF](#)  
[CZRU52C5V6](#) [CDBF0245](#) [CDBU0530-HF](#) [CPDU5V0U-HF](#) [CDBB540-HF](#) [CZRU52C3V9](#) [ACDBA1200-HF](#) [CDBHM140L-HF](#)  
[ACGRKM4007-HF](#) [CPDU12V-HF](#) [CDBMT160-HF](#) [CZRER52C2](#) [CPDV5-3V3UP](#) [ACPDQC5V0C-HF](#) [1.5KE36A-G](#) [CDBQR0230L-HF](#)  
[CPDU5V0-HF](#) [CDBHM160L-HF](#) [CZRU52C13-HF](#) [CZRU5V1B](#) [CDBA2200-HF](#) [CDBQR54-HF](#) [ZENER-KIT](#) [CGRA4004-G](#) [CGRM4007-](#)  
[HF](#) [KBPC1501-G](#) [CURMT104-HF](#) [CDBQR70-HF](#) [CDBA140-HF](#) [CDSQR4148-HF](#) [KBPC2504-G](#) [ACGRAS1W-HF](#) [CDBUR0140L-HF](#)  
[ACDBA560-HF](#) [KBPC5004-G](#) [ACGRA4001-HF](#) [CDBUR70](#) [DB106-G](#) [KBPC1502-G](#) [TV02W280B-HF](#) [DF06-G](#) [CDBU0130-HF](#)