

AUSMCJ10(C)A-HF Thru. AUSMCJ190(C)A-HF

Working Peak Reverse Voltage: 10 to 190 Volts

Power Dissipation: 1500Watts

RoHS Device
Halogen Free

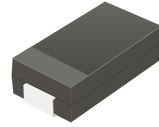

Features

- Low profile package.
- Ideal for automated placement.
- Available in Uni-directional and Bi-directional.
- 1500W peak pulse power capability with a 10/1000µs waveform.
- Excellent clamping capability.
- Very fast response time.
- Low incremental surge resistance.
- Meets MSL level 1, per J-STD-020C, LF maximum peak of 260°C.
- AEC-Q101 Qualified.

Mechanical Data

- Case: DO-214AB/SMC, molded plastic.
- Epoxy: UL 94V-0 rate flame retardant.
- Terminals: Matte tin plated leads, solderable per J-STD-002 and JESD22-B102.
- Polarity: For Uni-directional types the band denotes end, no marking on Bi-directional types.

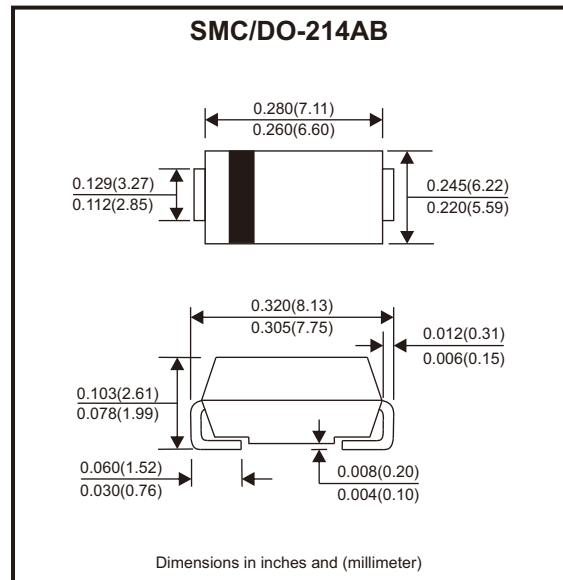

Circuit Diagram

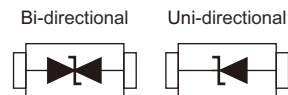

Maximum Ratings and Electrical Characteristics (TA=25°C unless otherwise specified)

Characteristics	Symbol	Value	Units
Peak power dissipation, with a 10/1000µs waveform (Note 1, 2)	P _{PPM}	1500	W
Peak pulse current, with a 10/1000µs waveform (Note 1)	I _{PPM}	See Next Table	A
Power dissipation, on infinite heat sink at T _L = 75°C (Note 2)	P _D	6.5	W
Peak forward surge current, 8.3ms single half sine-wave unidirectional only (Note 3)	I _{FSM}	200	A
Maximum instantaneous forward voltage at 100A for unidirectional only (Note 4)	V _{FM}	3.5	V
Typical thermal resistance, junction to ambient (Note 5)	R _{θJA}	75	°C/W
Typical thermal resistance, junction to lead	R _{θJL}	15	°C/W
Operating junction and storage temperature range	T _J , T _{STG}	-55 to +150	°C

- Notes: 1. Non-repetitive current pulse, per Fig.3 and derated above Ta = 25°C per Fig.2.
 2. Mounted on 0.31 x 0.31" (8.0 x 8.0mm) copper pads to each terminal.
 3. Measured on 8.3ms single half sine-wave or equivalent square wave, duty cycle = 4 pulses per minute maximum.
 4. VF = 3.5V max for devices of VBR ≤ 220V.
 5. Mounted on minimum recommended pad layout.

SMD Transient Voltage Suppressor

Electrical Characteristics (TA=25°C unless otherwise specified)

Part No.	Breakdown Voltage V _{BR} @ I _T			Maximum Reverse Leakage @V _{RWM} I _R (μA)	Working Peak Reverse Voltage V _{RWM} (V)	Maximum Reverse Surge Current (Note 1) I _{PP} (A)	Maximum Clamping Voltage @ I _{PP} V _C (V)	Device Marking Code	
	Min. (V)	Max. (V)	I _T (mA) t _p ≤ 50ms					UNI	BI
AUSMCJ10(C)A-HF	11.10	12.30	1	5.0	10.0	88.2	17.0	10A	10CA
AUSMCJ11(C)A-HF	12.20	13.50	1	5.0	11.0	82.4	18.2	11A	11CA
AUSMCJ12(C)A-HF	13.30	14.70	1	5.0	12.0	75.4	19.9	12A	12CA
AUSMCJ13(C)A-HF	14.40	15.90	1	1.0	13.0	69.8	21.5	13A	13CA
AUSMCJ14(C)A-HF	15.60	17.20	1	1.0	14.0	64.7	23.2	14A	14CA
AUSMCJ15(C)A-HF	16.70	18.50	1	1.0	15.0	61.5	24.4	15A	15CA
AUSMCJ16(C)A-HF	17.80	19.70	1	1.0	16.0	57.7	26.0	16A	16CA
AUSMCJ17(C)A-HF	18.90	20.90	1	1.0	17.0	54.4	27.6	17A	17CA
AUSMCJ18(C)A-HF	20.00	22.10	1	1.0	18.0	51.4	29.2	18A	18CA
AUSMCJ19(C)A-HF	21.10	23.30	1	1.0	19.0	48.7	30.8	19A	19CA
AUSMCJ20(C)A-HF	22.20	24.50	1	1.0	20.0	46.3	32.4	20A	20CA
AUSMCJ22(C)A-HF	24.40	26.90	1	1.0	22.0	42.3	35.5	22A	22CA
AUSMCJ24(C)A-HF	26.70	29.50	1	1.0	24.0	38.6	38.9	24A	24CA
AUSMCJ26(C)A-HF	28.90	31.90	1	1.0	26.0	35.6	42.1	26A	26CA
AUSMCJ28(C)A-HF	31.10	34.40	1	1.0	28.0	33.0	45.4	28A	28CA
AUSMCJ30(C)A-HF	33.30	36.80	1	1.0	30.0	31.0	48.4	30A	30CA
AUSMCJ33(C)A-HF	36.70	40.60	1	1.0	33.0	28.1	53.3	33A	33CA
AUSMCJ36(C)A-HF	40.00	44.20	1	1.0	36.0	25.8	58.1	36A	36CA
AUSMCJ40(C)A-HF	44.40	49.10	1	1.0	40.0	23.3	64.5	40A	40CA
AUSMCJ43(C)A-HF	47.80	52.80	1	1.0	43.0	21.6	69.4	43A	43CA
AUSMCJ45(C)A-HF	50.00	55.30	1	1.0	45.0	20.6	72.7	45A	45CA
AUSMCJ48(C)A-HF	53.30	58.90	1	1.0	48.0	19.4	77.4	48A	48CA
AUSMCJ51(C)A-HF	56.70	62.70	1	1.0	51.0	18.2	82.4	51A	51CA
AUSMCJ54(C)A-HF	60.00	66.30	1	1.0	54.0	17.2	87.1	54A	54CA
AUSMCJ58(C)A-HF	64.40	71.20	1	1.0	58.0	16.0	93.6	58A	58CA
AUSMCJ60(C)A-HF	66.70	73.70	1	1.0	60.0	15.5	96.8	60A	60CA
AUSMCJ64(C)A-HF	71.10	78.60	1	1.0	64.0	14.6	103.0	64A	64CA
AUSMCJ70(C)A-HF	77.80	86.00	1	1.0	70.0	13.3	113.0	70A	70CA
AUSMCJ75(C)A-HF	83.30	92.10	1	1.0	75.0	12.4	121.0	75A	75CA
AUSMCJ78(C)A-HF	86.70	95.80	1	1.0	78.0	11.9	126.0	78A	78CA
AUSMCJ80(C)A-HF	88.80	97.60	1	1.0	80.0	11.6	129.6	80A	80CA
AUSMCJ85(C)A-HF	94.40	104.00	1	1.0	85.0	10.9	137.0	85A	85CA
AUSMCJ90(C)A-HF	100.00	111.00	1	1.0	90.0	10.3	146.0	90A	90CA
AUSMCJ100(C)A-HF	111.00	123.00	1	1.0	100.0	9.3	162.0	100A	100CA
AUSMCJ110(C)A-HF	122.00	135.00	1	1.0	110.0	8.5	177.0	110A	110CA
AUSMCJ120(C)A-HF	133.00	147.00	1	1.0	120.0	7.8	193.0	120A	120CA
AUSMCJ130(C)A-HF	144.0	159.0	1	1.0	130.0	7.2	209.0	130A	130CA
AUSMCJ140(C)A-HF	155.0	171.0	1	1.0	140.0	6.6	226.8	140A	140CA
AUSMCJ150(C)A-HF	167.0	185.0	1	1.0	150.0	6.2	243.0	150A	150CA
AUSMCJ160(C)A-HF	178.0	197.0	1	1.0	160.0	5.8	259.0	160A	160CA
AUSMCJ170(C)A-HF	189.0	209.0	1	1.0	170.0	5.5	275.0	170A	170CA
AUSMCJ180(C)A-HF	200.0	220.0	1	1.0	180.0	5.1	291.6	180A	180CA
AUSMCJ190(C)A-HF	211.0	232.0	1	1.0	190.0	4.9	307.8	190A	190CA

Notes: 1. Surge current waveform per Fig.3 and derated per Fig.2.
2. For Bi-directional devices, use suffix CA.

Ratings and Characteristics Curve (AUSMCJ-HF Series)

Fig.1 - Peak Pulse Power Rating Curve

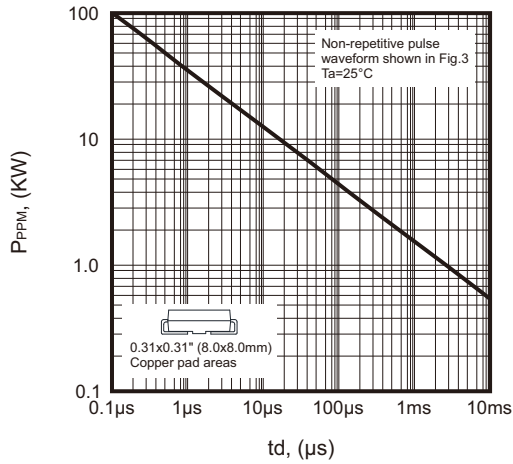

Fig.2 - Pulse Power or Current vs. Junction Temperature

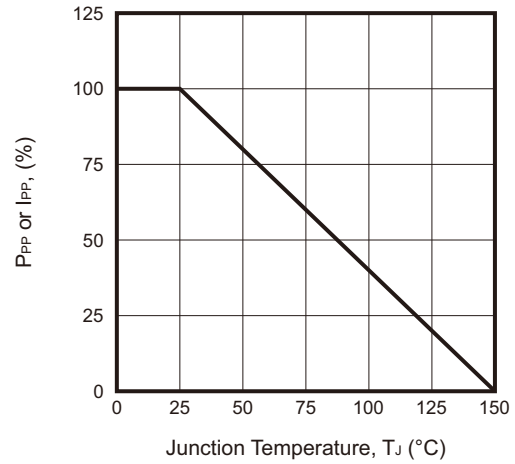

Fig.3 - Pulse Waveform

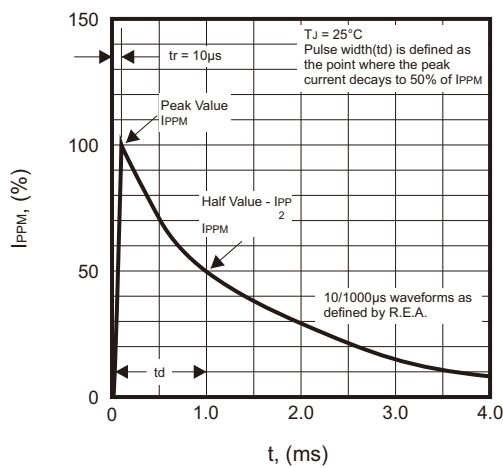

Fig.4 - Typical Transient Thermal Impedance

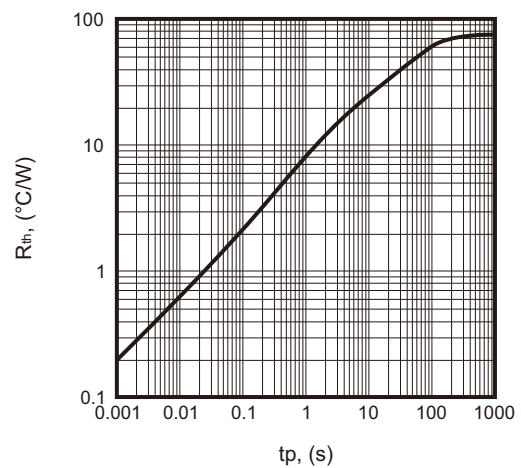

Fig.5 - Maximum Non-Repetitive Surge Current

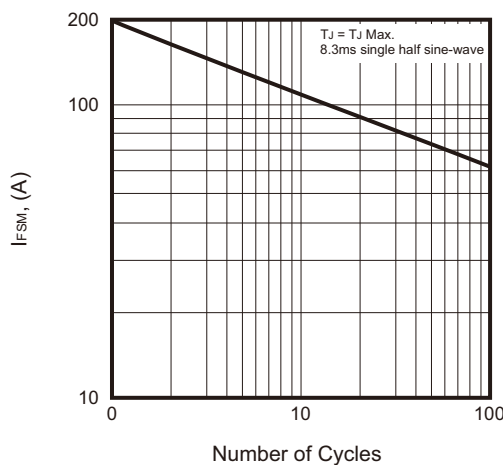
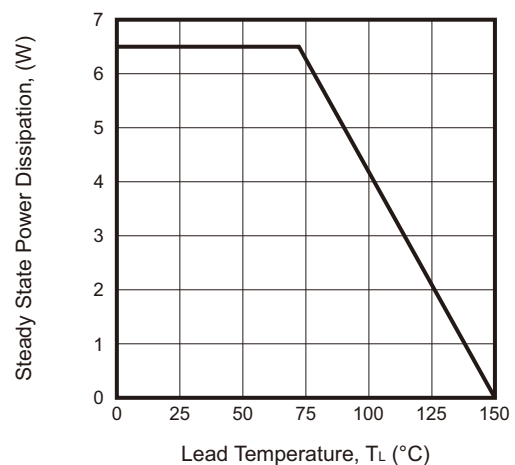
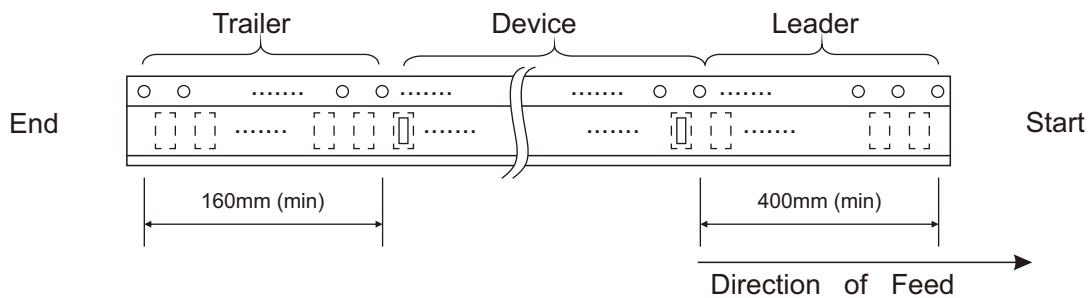
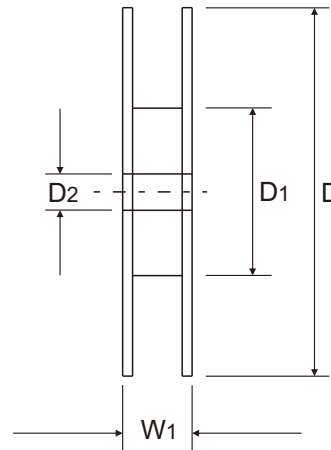
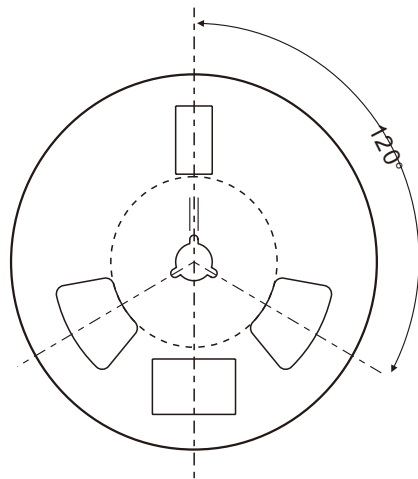
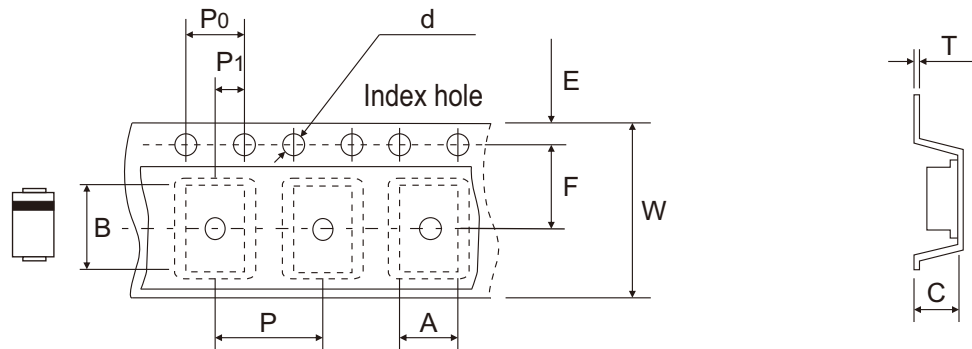

Fig.6 - Steady State Power Derating Curve



Reel Taping Specification



DO-214AB (SMC)	SYMBOL	A	B	C	d	D	D1	D2	
	(mm)	See Note 1				1.55 ± 0.05	330 ± 1.00	75.00 ± 1.00	14.00 ± 1.00
	(inch)	See Note 1				0.061 ± 0.002	12.992 ± 0.039	2.953 ± 0.039	0.551 ± 0.039

DO-214AB (SMC)	SYMBOL	E	F	P	P0	P1	T	W	W1
	(mm)	1.75 ± 0.10	7.50 ± 0.10	8.00 ± 0.10	4.00 ± 0.10	2.00 ± 0.10	0.30 ± 0.02	16.00 ± 0.30	22.00 ± 1.00
	(inch)	0.069 ± 0.004	0.295 ± 0.004	0.315 ± 0.004	0.157 ± 0.004	0.079 ± 0.004	0.012 ± 0.001	0.630 ± 0.012	0.866 ± 0.039

Note: 1. A, B, and C the clearance between the component and the cavity must be within 0.5mm max. for 8mm tape and 12mm tape, 1.0mm max. for 16mm tape and 24mm tape.

Company reserves the right to improve product design, functions and reliability without notice. REV:A

Marking Code

Part Number	Marking Code
AUSMCJ-HF Series	See Page.2



Product type marking code
Cathode band

xxxxx = Marking code (see Page.2)

Suggested P.C.B. PAD Layout

SIZE	DO-214AB(SMC)	
	(mm)	(inch)
A	3.03	0.119
B	3.82	0.150
C	3.84	0.151
D	9.90	0.390

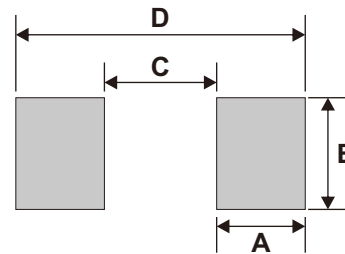

Note: 1. The pad layout is for reference purpose only.

Standard Packaging

Case Type	REEL PACK	
	REEL (pcs)	Reel Size (inch)
DO-214AB (SMC)	3,000	13

X-ON Electronics

Largest Supplier of Electrical and Electronic Components

Click to view similar products for [ESD Suppressors / TVS Diodes](#) category:

Click to view products by [Comchip](#) manufacturer:

Other Similar products are found below :

[60KS200C](#) [D18V0L1B2LP-7B](#) [D5V0F4U5P5-7](#) [NTE4902](#) [P4KE27CA](#) [P6KE11CA](#) [P6KE8.2A](#) [SA60CA](#) [SA64CA](#) [SMBJ12CATR](#)
[SMBJ33CATR](#) [SMBJ6.5A](#) [SMBJ8.0A](#) [ESD101-B1-02ELS](#) [E6327](#) [ESD112-B1-02EL](#) [E6327](#) [ESD7451N2T5G](#) [19180-510](#) [CPDT-5V0USP-](#)
[HF](#) [3.0SMCJ33CA-F](#) [3.0SMCJ36A-F](#) [HSPC16701B02TP](#) [JANTX1N6126A](#) [D3V3Q1B2DLP3-7](#) [D55V0M1B2WS-7](#) [SCM1293A-04SO](#)
[ESD200-B1-CSP0201](#) [E6327](#) [SM12-7](#) [CEN955](#) [W/DATA](#) [VESD12A1A-HD1-GS08](#) [CPDQC5V0-HF](#) [D1213A-01LP4-7B](#) [ESD101-B1-02EL](#)
[E6327](#) [AOZ8808DI-03](#) [5KP15A](#) [5KP48A](#) [5KP90A](#) [ESD3V3D7-TP](#) [15KPA36A-LF](#) [P4KE56CA](#) [P4KE68A](#) [P4KE91CATR](#) [P6KE120A](#)
[P6KE13CA](#) [P6KE43CA](#) [P6KE6.8CA](#) [P6KE8.2](#) [P6SMBJ20CA](#) [JANTX1N6072A](#) [SR2835ESKG](#) [SA90CA](#)