

BAV19WS-HF Thru. BAV21WS-HF

RoHS Device

Halogen Free

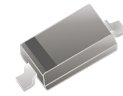

Features

- Fast switching device ($T_{rr} < 50\text{nS}$).
- Power dissipation of 250mW.
- High stability and high reliability.
- Low reverse leakage.

Mechanical data

- Case: SOD-323, molded plastic.
- Polarity: Color band denotes cathode end.
- Epoxy UL: 94V-0.
- Mounting position: Any.

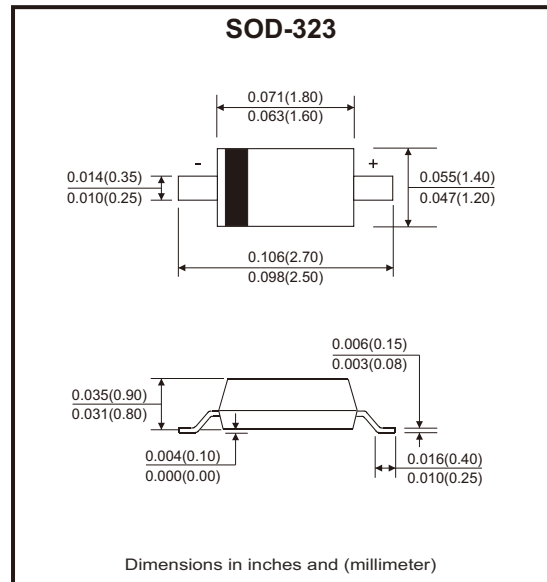

Circuit Diagram



Maximum Rating (at $T_a=25^\circ\text{C}$ unless otherwise noted)

Parameter	Symbol	BAV19WS-HF	BAV20WS-HF	BAV21WS-HF	Unit
Reverse voltage	V_R	120	200	250	V
Peak reverse voltage	V_{RM}	100	150	250	V
Power dissipation	P_D	250			mW
Average rectified current	I_o	200			mA
Non-repetitive peak forward current	I_{FM}	400			mA
Non-repetitive peak forward surge current @ $t=8.3\text{ms}$	I_{FSM}	2			A
Thermal resistance junction to ambient air	$R_{\theta JA}$	500			$^\circ\text{C/W}$
Operating junction temperature	T_J	150			$^\circ\text{C}$
Storage temperature range	T_{STG}	-65 to +150			$^\circ\text{C}$

Note: Valid provided that electrodes are kept at ambient temperature.

Electrical Characteristics (at Ta=25°C unless otherwise noted)

Parameter	Symbol	Conditions	Min	Max	Unit
Reverse voltage	VRB	I _B = 100μA	120 200 250		V
Reverse leakage current	I _R	V _R = 100V V _R = 150V V _R = 200V		0.1	μA
Forward voltage	V _F	I _F = 100mA I _F = 200mA		1.0 1.25	V
Reverse recovery time	t _{rr}	I _F = 30mA, I _R = 30mA, R _L = 100Ω, I _{RR} = 3mA		50	nS
Capacitance	C	V _R = 0V, f = 1MHz		5	pF

Typical Rating and Characteristic Curves (BAV19WS-HF Thru. BAV21WS-HF)

Fig.1 - Forward Characteristics

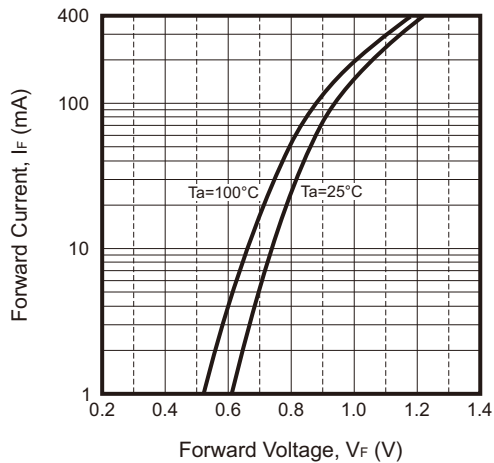

Fig.2 - Reverse Characteristics

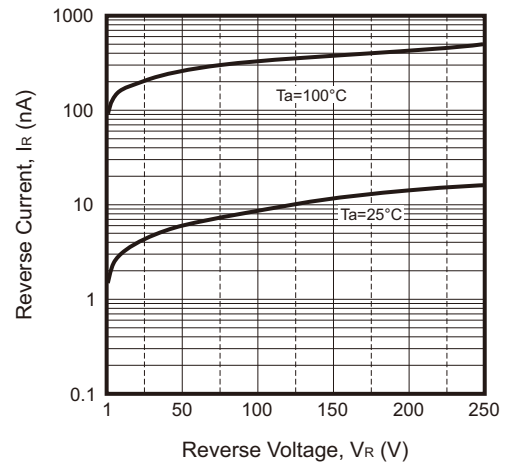

Fig.3 - Capacitance Characteristics

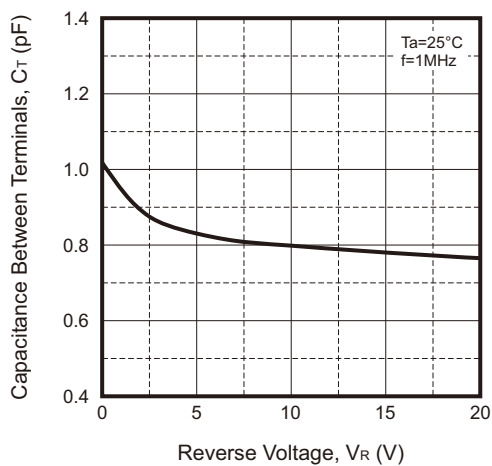
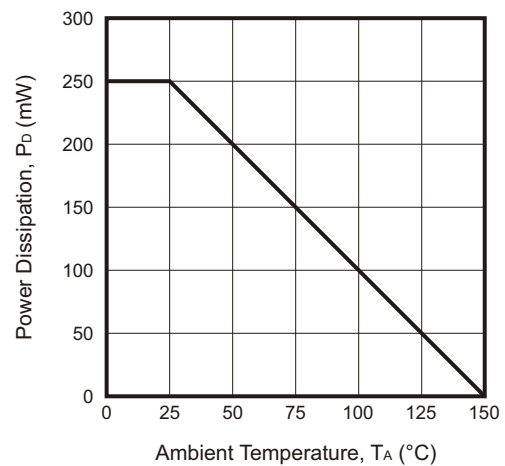
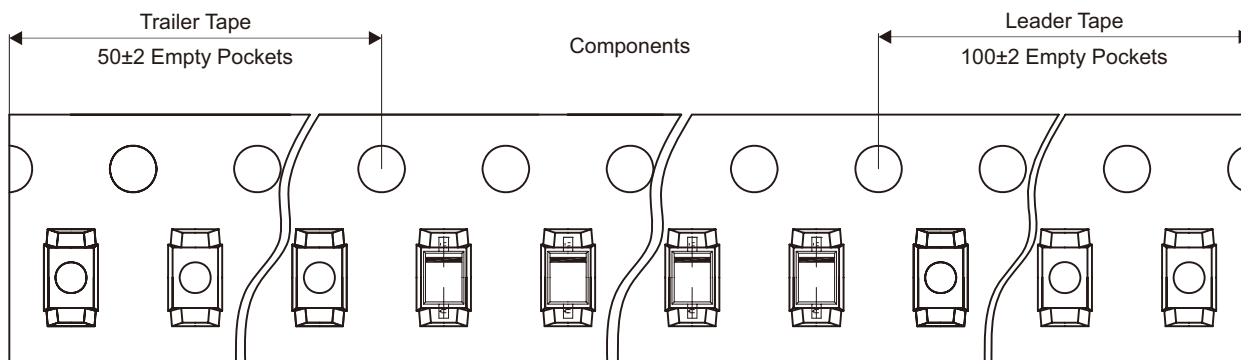
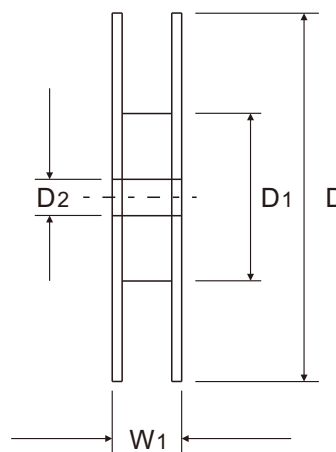
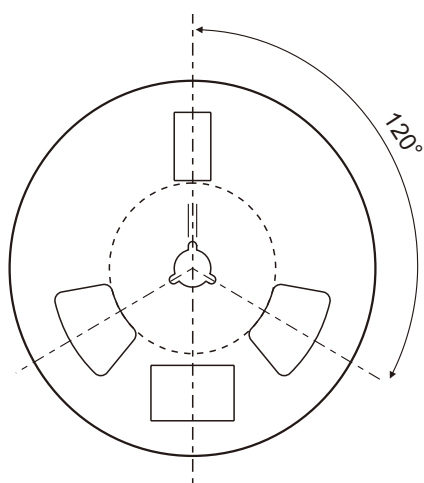
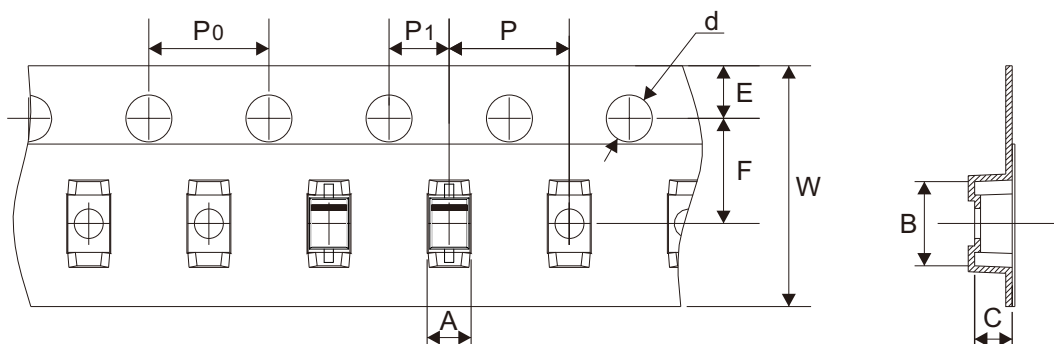

Fig.4 - Power Derating Curve



Reel Taping Specification



SOD-323	SYMBOL	A	B	C	d	D	D1	D2
	(mm)	1.46 ± 0.05	2.90 ± 0.05	1.25 ± 0.05	1.50 ± 0.10	178.00 ± 2.00	54.40 ± 1.00	13.00 ± 1.00
	(inch)	0.057 ± 0.002	0.114 ± 0.002	0.049 ± 0.002	0.059 ± 0.004	7.008 ± 0.079	2.142 ± 0.039	0.512 ± 0.039

SOD-323	SYMBOL	E	F	P	P0	P1	W	W1
	(mm)	1.75 ± 0.10	3.50 ± 0.10	4.00 ± 0.10	4.00 ± 0.10	2.00 ± 0.10	8.00 + 0.30 - 0.10	12.30 ± 1.00
	(inch)	0.069 ± 0.004	0.138 ± 0.004	0.157 ± 0.004	0.157 ± 0.004	0.079 ± 0.004	0.315 + 0.012 - 0.004	0.484 ± 0.039

Marking Code

Part Number	Marking Code
BAV19WS-HF	A8
BAV20WS-HF	T2
BAV21WS-HF	T3



xx = Product type marking code

█ = Cathode band

Suggested P.C.B. PAD Layout

SIZE	SOD-323	
	(mm)	(inch)
A	0.80	0.031
B	0.80	0.031
C	3.00	0.118

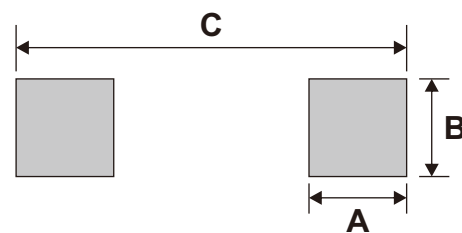

Standard Packaging

Case Type	REEL PACK	
	REEL (pcs)	Reel Size (inch)
SOD-323	3,000	7

X-ON Electronics

Largest Supplier of Electrical and Electronic Components

Click to view similar products for [Small Signal Switching Diodes](#) category:

Click to view products by [Comchip](#) manufacturer:

Other Similar products are found below :

[BAS16E6433HTMA1](#) [SHN2D02FUTW1T1G](#) [BAS 16-02L E6327](#) [BAS 16-02V H6327](#) [BAS 21U E6327](#) [BAS 28 E6327](#) [BAW56DWQ-7-F](#)
[BAW56M3T5G](#) [IDW40E65D1](#) [IDW40E65D2](#) [SMMSD4148T3G](#) [NSVDAN222T1G](#) [CDSZC01100-HF](#) [BAS28-7](#) [JANTX1N6640](#)
[BAW56HDW-13](#) [BAV99TQ-13-F](#) [SMSD1002T1G](#) [LS4148](#) [IDV15E65D2](#) [W0503RH200S0L](#) [M0268SJ200NLF](#) [M0268RJ200NLF](#)
[DAN217U-TP](#) [BAV21W-HE3_A-08](#) [BAV99-HE3_A-08](#) [BAW56-HE3_A-08](#) [BAS16-HE3_A-08](#) [BAS16D-HE3_A-08](#) [BAV19W-HE3_A-08](#)
[BAS20-HE3_A-08](#) [BAL99-HE3_A-08](#) [BAV23C-HE3_A-08](#) [DHVSD3004BRM-7](#) [DLLFSD01LP3Q-7](#) [BAS16VVQ-7](#)
[IDWD100E120D7XKSA1](#) [IDWD120E120D7XKSA1](#) [IDWD140E120D7XKSA1](#) [IDWD30E120D7XKSA1](#) [IDWD40E120D7XKSA1](#)
[IDWD50E120D7XKSA1](#) [IDWD60E120D7XKSA1](#) [IDWD75E120D7XKSA1](#) [BAS21TWQ-7](#) [BAV21WQ-7-F](#) [MMBD4448HADWQ-7-F](#)
[1N4148WSQ-13-F](#) [BAW56WQ-7-F](#) [BAS716-TP](#)