

CDBB3150-HF Thru. CDBB3200-HF

Reverse Voltage: 150 to 200 Volts

Forward Current: 3.0 Amp

RoHS Device

Halogen Free

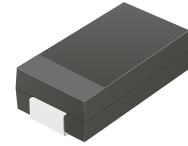

Features

- Low Profile surface mount applications in order to optimize board space.
- Low power loss, high efficiency.
- High current capability, low forward voltage drop.
- High surge capability.
- Guard ring for overvoltage protection.
- Ultra high-speed switching.
- Silicon epitaxial planar chip, metal silicon junction.

Mechanical data

- Epoxy: UL94-V0 rate flame retardant.
- Case: Molded plastic, DO-214AA / SMB
- Terminals: solderable per MIL-STD-750, method 2026.
- Polarity: Indicated by cathode band.
- Weight: 0.091 grams

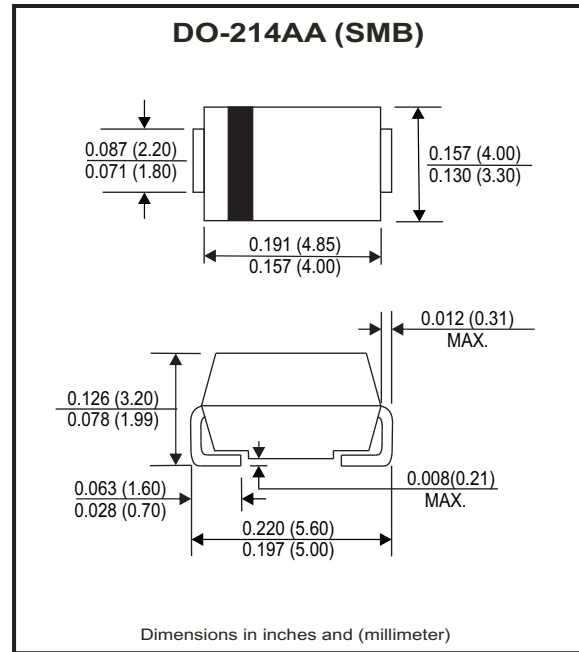

Maximum Ratings and Electrical Characteristics

Ratings at $T_a=25^{\circ}\text{C}$ unless otherwise noted.
Single phase, half wave, 60Hz, resistive or inductive loaded.
For capacitive load, derate current by 20% .

| Parameter | Symbol | CDBB 3150-HF | CDBB 3200-HF | Unit |
|---|-----------|--------------|--------------|--------------------|
| Max. repetitive peak reverse voltage | V_{RRM} | 150 | 200 | V |
| Max. DC blocking voltage | V_{DC} | 150 | 200 | V |
| Max. RMS voltage | V_{RMS} | 105 | 140 | V |
| Max. instantaneous forward voltage @ 3.0A, $T_A=25^{\circ}\text{C}$ | V_F | 0.87 | 0.90 | V |
| Operating Temperature | T_J | -50 to +175 | | $^{\circ}\text{C}$ |

| Parameter | Conditions | Symbol | MIN. | TYP. | MAX. | Unit |
|----------------------------|--|-----------------|------|------|------|-----------------------------|
| Forward rectified current | see Fig.1 | I_o | | | 3.0 | A |
| Forward surge current | 8.3ms single half sine-wave superimposed on rate load (JEDEC method) | I_{FSM} | | | 70 | A |
| Reverse Current | $V_R = V_{RRM}$ $T_A=25^{\circ}\text{C}$ | I_R | | | 0.5 | mA |
| | $V_R = V_{RRM}$ $T_A=100^{\circ}\text{C}$ | I_R | | | 20 | mA |
| Thermal Resistance | Junction to ambient | $R_{\theta JA}$ | | 55 | | $^{\circ}\text{C}/\text{W}$ |
| Diode Junction capacitance | f=1MHz and applied 4V DC reverse Voltage | C_J | | 250 | | pF |
| Storage temperature | | T_{STG} | -50 | | +175 | $^{\circ}\text{C}$ |

Company reserves the right to improve product design , functions and reliability without notice.

REV: C

RATING AND CHARACTERISTIC CURVES (CDBB3150-HF thru. CDBB3200-HF)

Fig.1 - Typical Forward Current Derating Curve

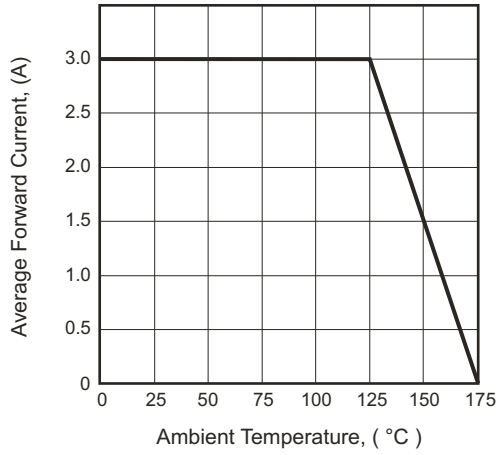

Fig.2 - Typical Forward Characteristics

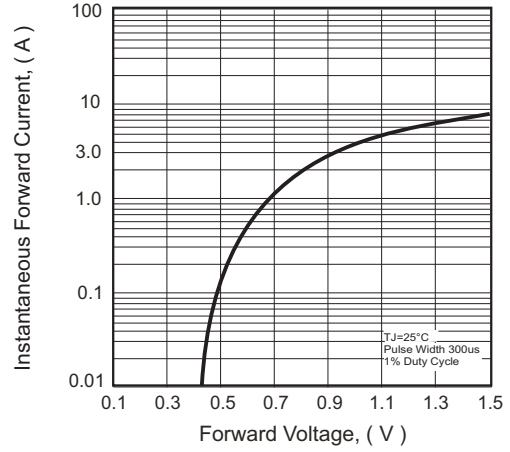

Fig.3 - Maximum Non-repetitive Forward Surge Current

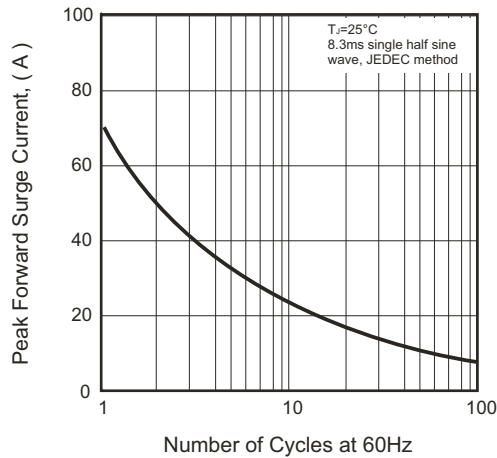

Fig.4 - Typical Junction Capacitance

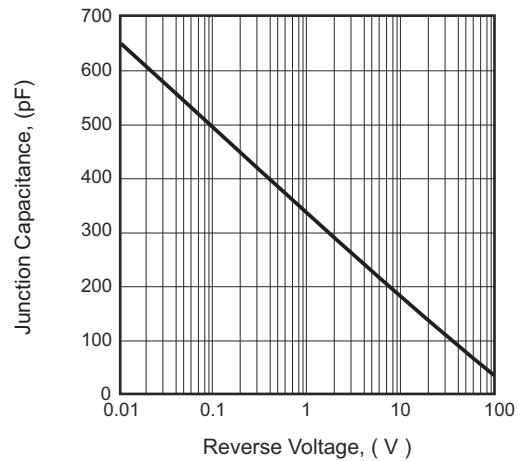
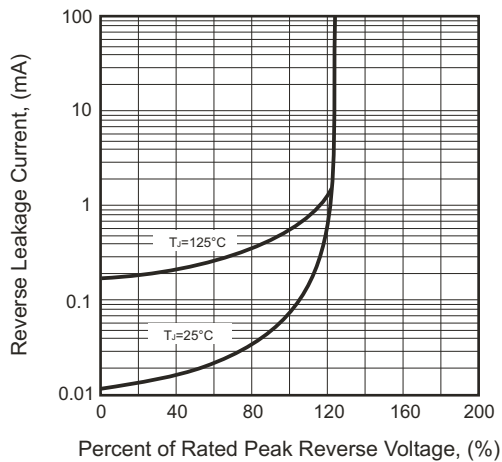
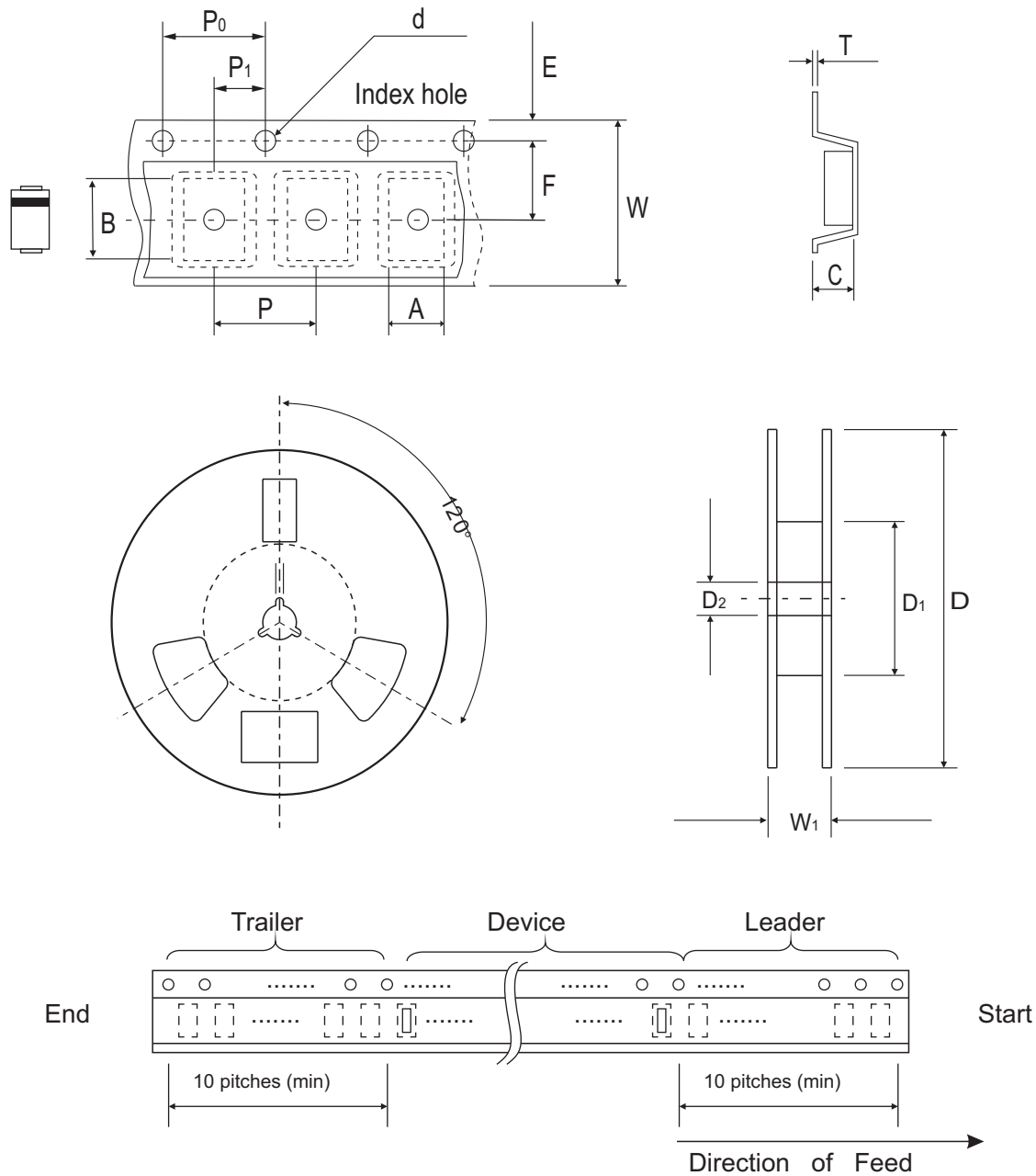

Fig.5 - Typical Reverse Characteristics



Reel Taping Specification



| DO-214AA (SMB) | SYMBOL | A | B | C | d | D | D1 | D2 |
|-------------------|--------|---------------|---------------|---------------|---------------|---------------|------------|---------------|
| | (mm) | 4.00 ± 0.10 | 5.90 ± 0.10 | 3.00 ± 0.10 | 1.50 ± 0.10 | 330 ± 2.00 | 50.0 MIN. | 13.50 ± 0.50 |
| | (inch) | 0.157 ± 0.004 | 0.232 ± 0.004 | 0.118 ± 0.004 | 0.059 ± 0.004 | 12.99 ± 0.079 | 1.969 MIN. | 0.531 ± 0.020 |

| DO-214AA (SMB) | SYMBOL | E | F | P | P0 | P1 | T | W | W1 |
|-------------------|--------|---------------|---------------|---------------|---------------|---------------|---------------|---------------|---------------|
| | (mm) | 1.75 ± 0.10 | 5.50 ± 0.10 | 8.00 ± 0.10 | 4.00 ± 0.10 | 2.00 ± 0.10 | 0.60 ± 0.10 | 12.0 ± 0.30 | 18.4 ± 1.00 |
| | (inch) | 0.069 ± 0.004 | 0.217 ± 0.004 | 0.315 ± 0.004 | 0.157 ± 0.004 | 0.079 ± 0.004 | 0.236 ± 0.004 | 0.472 ± 0.012 | 0.724 ± 0.040 |

Company reserves the right to improve product design, functions and reliability without notice.

REV: C

Marking Code

| Part Number | Marking Code |
|-------------|--------------|
| CDBB3150-HF | SK315 |
| CDBB3200-HF | SK320 |

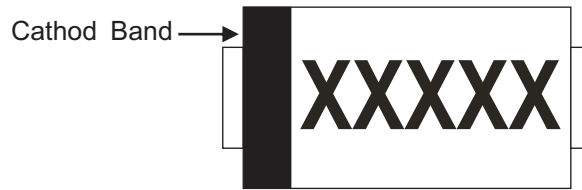

xxxxxx = Product type marking code

Suggested PAD Layout

| SIZE | DO-214AA (SMB) | |
|------|----------------|--------|
| | (mm) | (inch) |
| A | 4.30 | 0.169 |
| B | 2.50 | 0.098 |
| C | 2.30 | 0.091 |
| D | 6.80 | 0.268 |
| E | 1.80 | 0.071 |

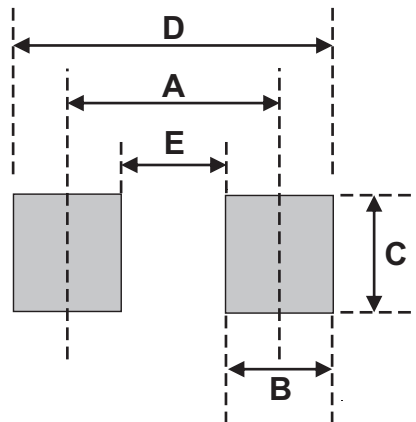

Standard Packaging

| Case Type | REEL PACK | |
|----------------|--------------|------------------|
| | REEL (pcs) | Reel Size (inch) |
| DO-214AA (SMB) | 3,000 | 13 |

X-ON Electronics

Largest Supplier of Electrical and Electronic Components

Click to view similar products for [Schottky Diodes & Rectifiers](#) category:

Click to view products by [Comchip](#) manufacturer:

Other Similar products are found below :

[MA4E2039](#) [D1FH3-5063](#) [MBR10100CT-BP](#) [MBR1545CT](#) [MMBD301M3T5G](#) [RB160M-50TR](#) [RB551V-30](#) [BAS16E6433HTMA1](#) [BAT](#)
[54-02LRH E6327](#) [NSR05F40QNXT5G](#) [NTE555](#) [JANS1N6640](#) [SB07-03C-TB-H](#) [SB1003M3-TL-W](#) [SK310-T](#) [SK32A-LTP](#) [SK33A-TP](#)
[SK34B-TP](#) [SS3003CH-TL-E](#) [GA01SHT18](#) [CRS10I30A\(TE85L,QM](#) [MA4E2501L-1290](#) [MBRA140TRPBF](#) [MBRB30H30CT-1G](#) [SB007-](#)
[03C-TB-E](#) [SK32A-TP](#) [SK33B-TP](#) [SK35A-TP](#) [SK38B-TP](#) [NRVBM120LT1G](#) [NTE505](#) [NTSB30U100CT-1G](#) [SS15E-TP](#) [VS-](#)
[6CWQ10FNHM3](#) [ACDBA1100LR-HF](#) [ACDBA1200-HF](#) [ACDBA140-HF](#) [ACDBA2100-HF](#) [ACDBA3100-HF](#) [CDBQC0530L-HF](#)
[CDBQC0240LR-HF](#) [ACDBA340-HF](#) [ACDBA260LR-HF](#) [ACDBA1100-HF](#) [SK310B-TP](#) [MA4E2502L-1246](#) [MA4E2502H-1246](#)
[NRVBM120ET1G](#) [NSR01L30MXT5G](#) [NTE573](#)