

CDBHD240-G Thru. CDBHD2100-G

Reverse Voltage: 40 to 100 Volts

Forward Current: 2.0 Amp

RoHS Device

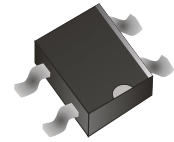

Features

- Schottky barrier chips in TO-269AA bridge.
- Metal semiconductor junction with guard ring.
- Silicon epitaxial planar chips.
- Very low forward drop down voltage.
- For use in low voltage, high efficiency inverters, free wheeling, and polarity protection applications.

Mechanical data

- Case: Molded plastic, TO-269AA(MDS)
- Epoxy: UL94-V0 rated flame retardant
- Terminals: Solder plated, solderable per MIL-STD-750, Method 2026
- Polarity: Marked on body
- Mounting Position: Any
- Weight: 0.13 grams(approx.).

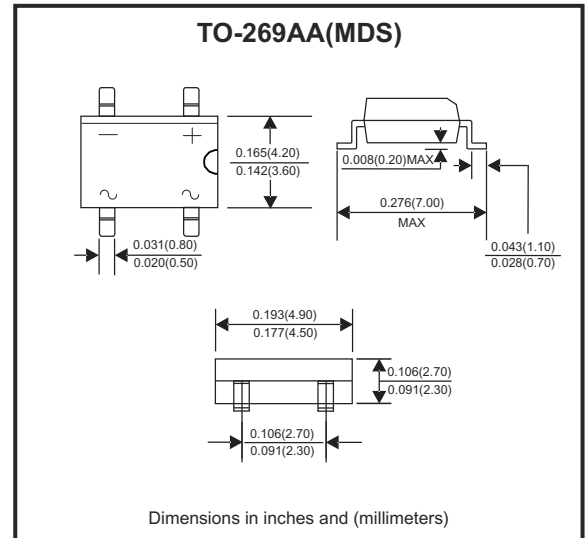

Circuit diagram

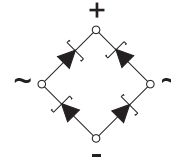

Maximum Ratings and Electrical Characteristics

Parameter	Conditions	Symbol	CDBHD 240-G	CDBHD 260-G	CDBHD 2100-G	Unit
Repetitive peak reverse voltage		V_{RRM}	40	60	100	V
Continuous reverse voltage		V_R	40	60	100	V
RMS voltage		V_{RMS}	28	42	70	V
Peak forward surge current	8.3ms single half sine-wave (JEDEC method)	I_{FSM}	50			A
Average forward rectified current	0.2x0.2"(5.0x5.0mm) copper pad, See fig.1	I_{AV}	2			A
Forward voltage	@ $I_F = 2.0A$ per element	V_F	0.50	0.70	0.85	V
Reverse current	$V_R = V_{RRM}, T_J = 25^\circ C$	I_R	0.5			mA
	$V_R = V_{RRM}, T_J = 100^\circ C$	I_R	20			
Typ. thermal resistance	Junction to ambient	$R_{\theta JA}$	75			$^\circ C/W$
	Junction to lead	$R_{\theta JL}$	20			
Typ. Diode junction capacitance	f=1MHz and applied 4V DC reverse voltage.	C_J	150			pF
Operating junction temperature Range		T_J	-55 to +125	-55 to +150		$^\circ C$
Storage temperature Range		T_{STG}	-65 to +175			$^\circ C$

RATING AND CHARACTERISTIC CURVES (CDBHD240-G Thru. CDBHD2100-G)

Fig.1 - Forward Current Derating Curve

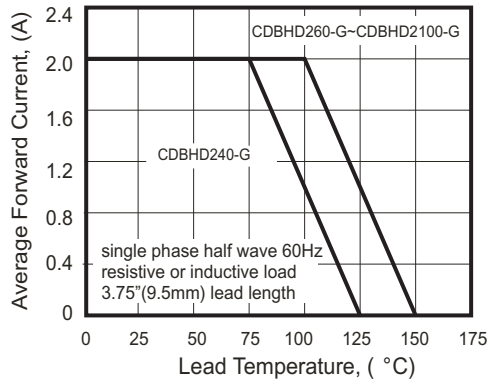

Fig. 2 - Maximum Non-Repetitive Peak Forward Surge Current

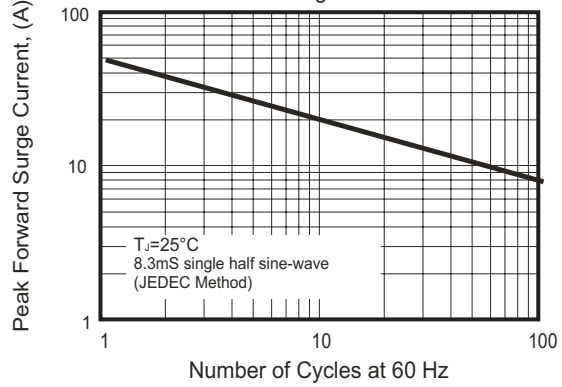

Fig. 3 - Typical Instantaneous Forward Characteristics

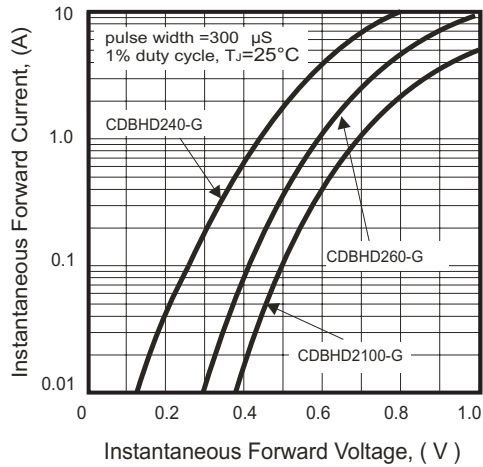

Fig. 4A - Typical Reverse Characteristics

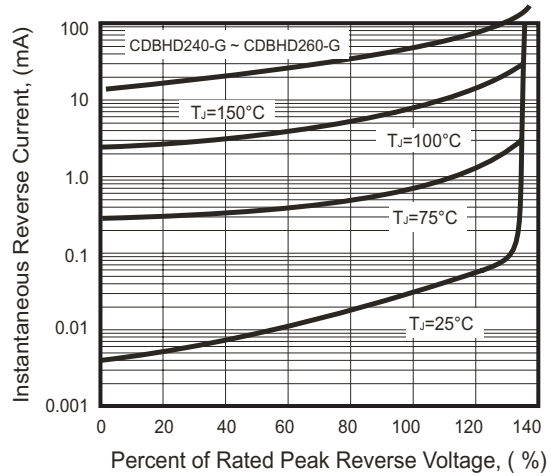

Fig. 5 - Typical Junction Capacitance

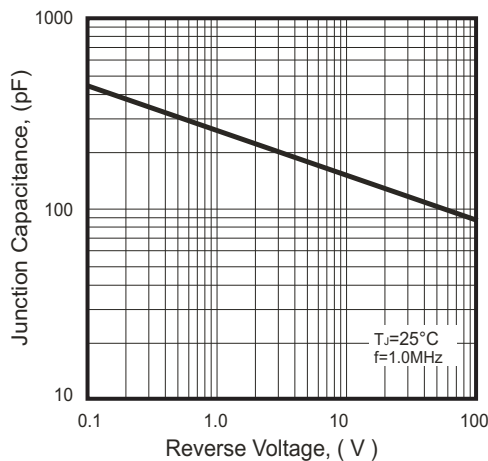
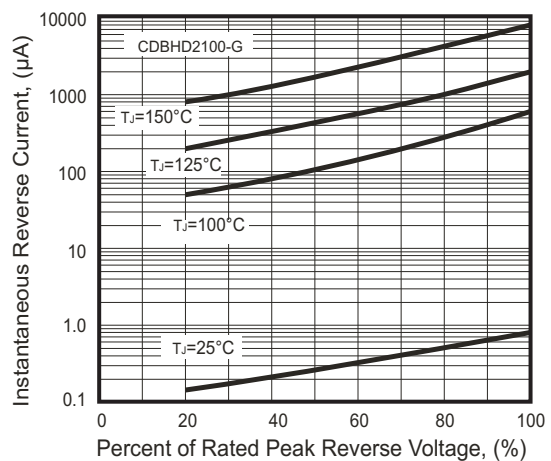
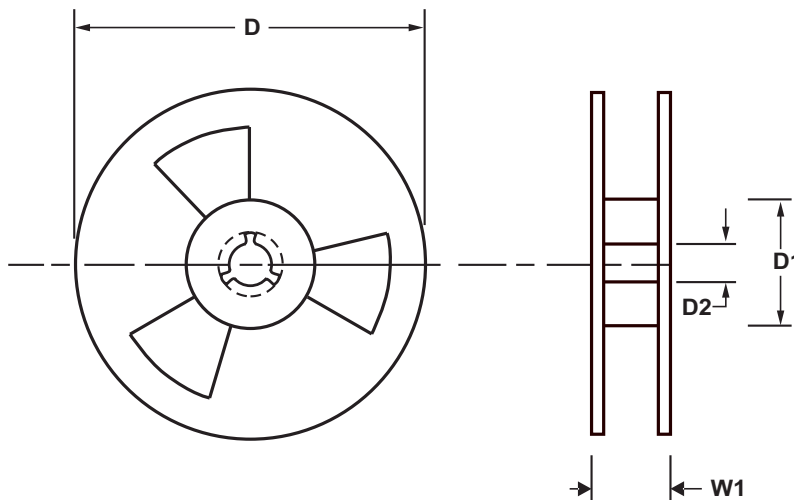
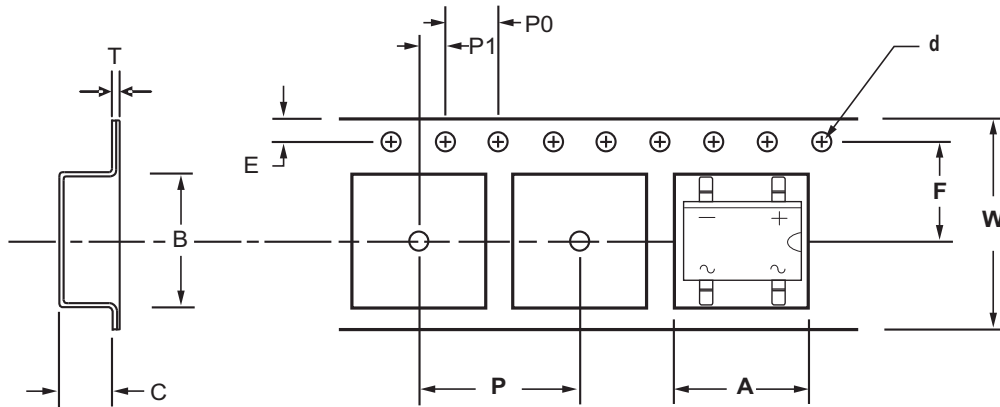

Fig. 4B - Typical Reverse Characteristics



Reel Taping Specification



TO-269AA(MDS)	SYMBOL	A	B	C	d	D	D1	D2
	(mm)	5.00 ± 0.10	7.24 ± 0.10	3.33 ± 0.10	1.50 ± 0.10	330 ± 2.00	50 MIN.	13.00 ± 0.50
	(inch)	0.197 ± 0.004	0.285 ± 0.004	0.131 ± 0.004	0.059 ± 0.004	12.992 ± 0.079	1.969 MIN.	0.512 ± 0.020

TO-269AA(MDS)	SYMBOL	E	F	P	P0	P1	W	W1
	(mm)	1.75 ± 0.10	5.50 ± 0.10	8.00 ± 0.10	4.00 ± 0.10	2.00 ± 0.10	12.00 ± 0.30	18.00 ± 1.00
	(inch)	0.069 ± 0.004	0.138 ± 0.004	0.315 ± 0.004	0.157 ± 0.004	0.079 ± 0.004	0.472 ± 0.012	0.709 ± 0.039

Marking Code

Part Number	Marking Code
CDBHD240-G	MDS24
CDBHD260-G	MDS26
CDBHD2100-G	MDS210

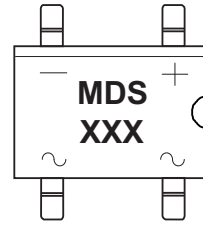

XX / XXX = Product type marking code

Suggested PAD Layout

SIZE	TO-269AA(MDS)	
	(mm)	(inch)
A	0.58	0.023
B	0.76	0.030
C	1.78	0.070
D	5.75	0.226

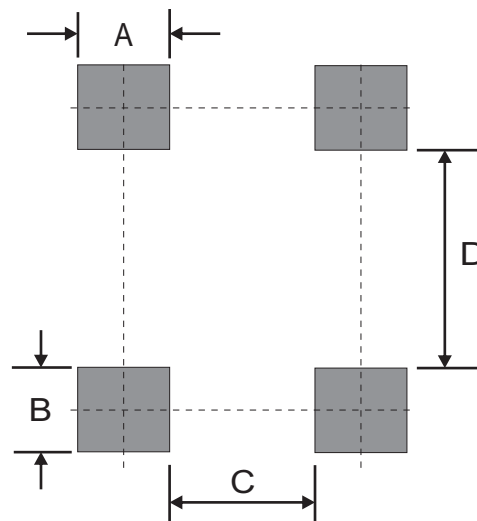

Standard Packaging

Case Type	REEL PACK	
	REEL (pcs)	Reel Size (inch)
TO-269AA(MDS)	2,500	13

X-ON Electronics

Largest Supplier of Electrical and Electronic Components

Click to view similar products for [Bridge Rectifiers](#) category:

Click to view products by [Comchip](#) manufacturer:

Other Similar products are found below :

[MB2510](#) [MB252](#) [MB356G](#) [MB358G](#) [GBJ1504-BP](#) [GBU10B-BP](#) [GBU15K-BP](#) [GBU4A-BP](#) [GBU4D-BP](#) [DB101-BP](#) [DF01](#) [DF10SA-E345](#)
[KBPC50-10S](#) [RS405GL-BP](#) [GBJ1502-BP](#) [GBU6M](#) [TB102M](#) [MB1510](#) [MB86](#) [TL401G](#) [MDA920A2](#) [TU602](#) [TU810](#) [MP5010W-BP](#)
[MP501W-BP](#) [MP502-BP](#) [KBPC25-02](#) [VBO160-12NO7](#) [VS-110MT120KPBF](#) [VS-60MT80KPBF](#) [DB105-BP](#) [DF1510S](#) [VS-](#)
[40MT160PAPBF](#) [GBU4G-BP](#) [GSIB15A80-E3/45](#) [DB104-BP](#) [D3SB60](#) [TB354](#) [GBJ2504-BP](#) [26MB100A](#) [B1S-G](#) [VS-40MT160KPBF](#)
[VUO162-16NO7](#) [ABS10-G](#) [GBU6B-BP](#) [GBJ1508-BP](#) [BR5010-G](#) [ABS6-G](#) [B125C800G-E4/51](#) [MSB15MH-13](#)