

CDBV3-54/S/C/A-HF

Reverse Voltage: 30 Volts

Forward Current: 200 mA

RoHS Device

Halogen free

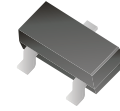

Features

- Design for mounting on small surface.
- High speed switching application, circuit protection.
- Low turn-on voltage.

Mechanical data

- Case: SOT-323, molded plastic.
- Terminals: solderable per MIL-STD-750, method 2026.
- Weight: 0.0055 gram (approx.).

Circuit diagram



CDBV3-54-HF

CDBV3-54S-HF

CDBV3-54C-HF

CDBV3-54A-HF

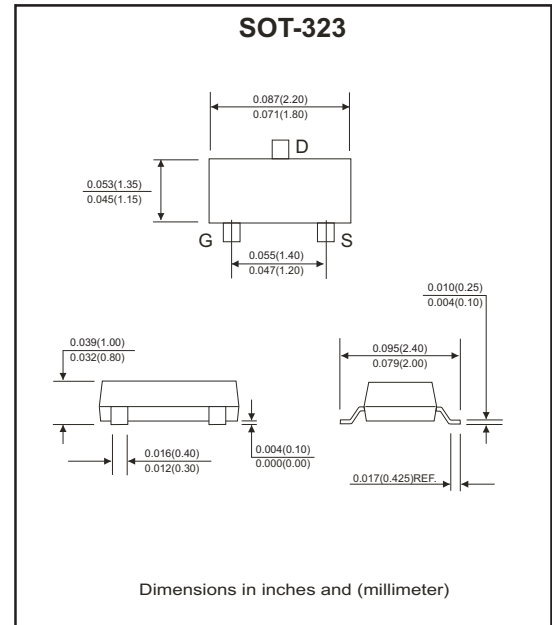

Maximum Ratings and Electrical Characteristics

(at Ta=25°C unless otherwise noted)

Parameter	Symbol	Conditions	Value	Units
Repetitive peak reverse voltage	V_{RRM}		30	V
Reverse voltage	V_R		30	V
Forward current	I_F		200	mA
Peak surge forward current	I_{FSM}	T=1.0 sec	0.6	A
Power dissipation	P_D		200	mW
Maximum forward voltage	V_F	@ $I_F=0.1mA$ @ $I_F=1mA$ @ $I_F=10mA$ @ $I_F=30mA$ @ $I_F=100mA$	0.24 0.32 0.40 0.50 1.00	V
Maximum reverse current	I_R	@ $V_R=25V$	2	μA
Maximum reverse recovery time	T_{rr}	$I_F=I_R=10mA, R_L=100\Omega$	5	nS
Maximum diode capacitance	C_J	$V_R=1V, f=1.0MHz$	10	pF
Maximum junction temperature	T_J		125	°C
Storage temperature	T_{STG}		-55 to +150	°C

Company reserves the right to improve product design, functions and reliability without notice.

REV:C

RATING AND CHARACTERISTIC CURVES (CDBV3-54/S/C/A-HF)

Fig.1 - Forward Characteristics

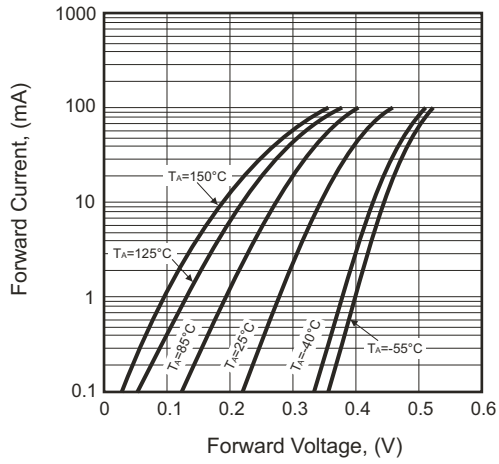

Fig.2 - Leakage Current

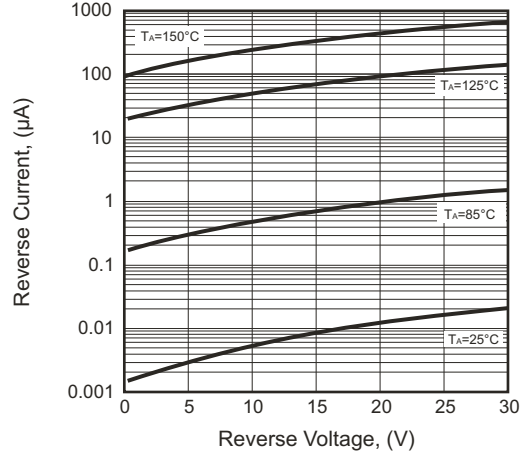

Fig.3 - Total Capacitance

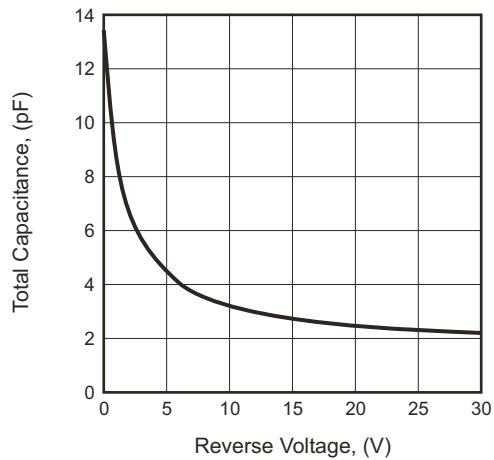
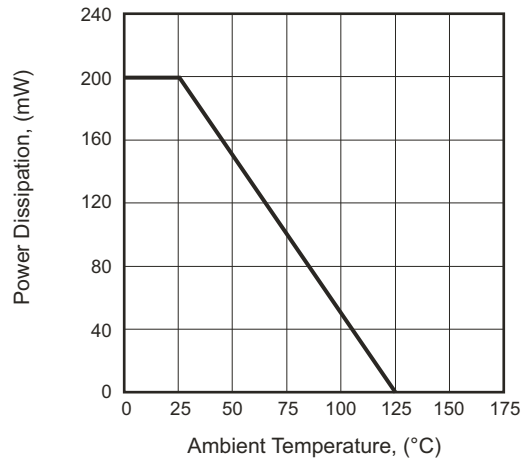
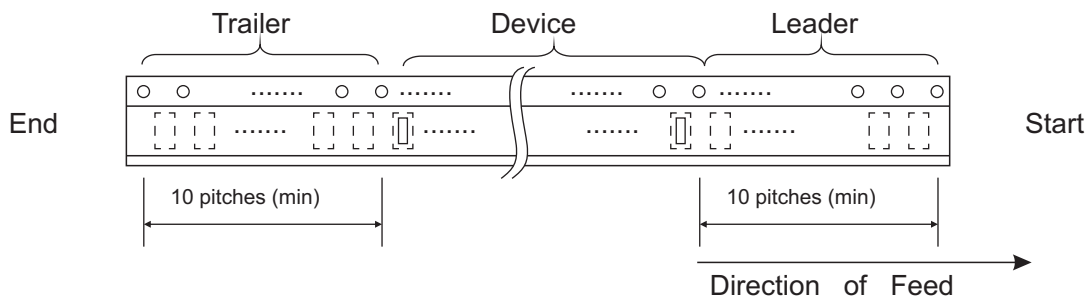
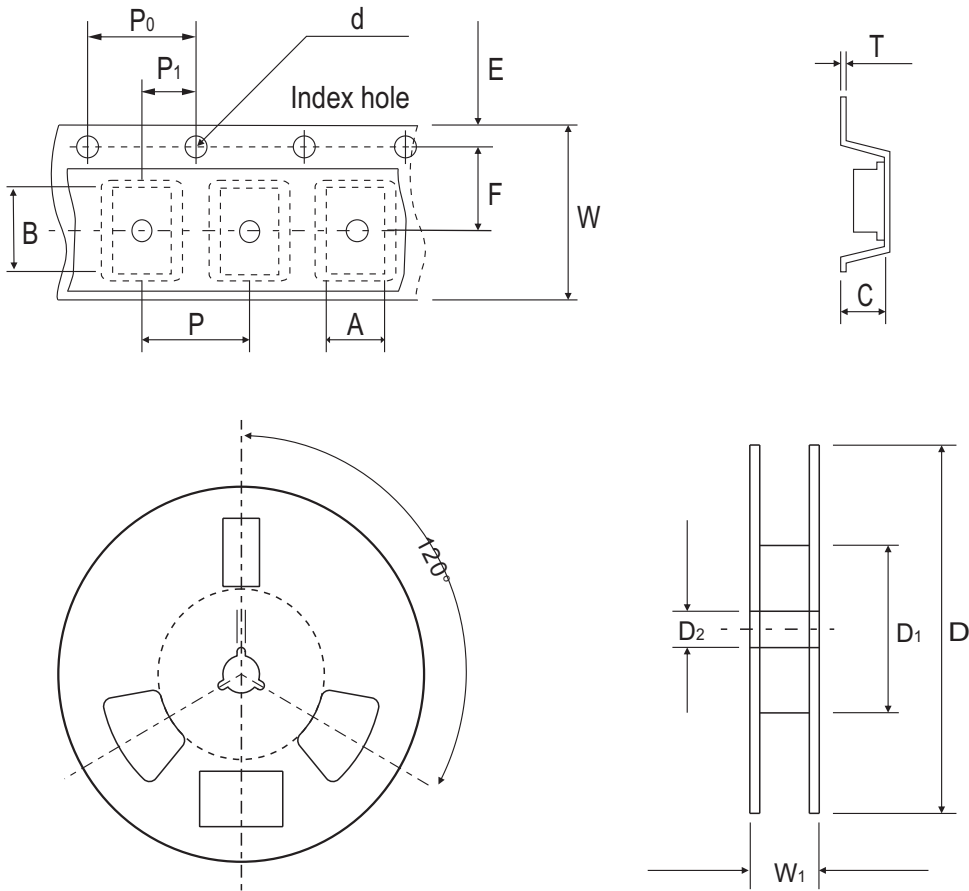

Fig.4 - Power Derating Curve



Company reserves the right to improve product design, functions and reliability without notice.

Reel Taping Specification



SOT-323	SYMBOL	A	B	C	d	D	D1	D2
	(mm)	2.20 ± 0.10	2.40 ± 0.10	1.15 ± 0.10	1.55 ± 0.10	178 ± 1	50.0 MIN.	13.0 ± 0.20
	(inch)	0.087 ± 0.004	0.094 ± 0.004	0.045 ± 0.004	0.061 ± 0.004	7.008 ± 0.040	1.969 MIN.	0.512 ± 0.008

SOT-323	SYMBOL	E	F	P	P0	P1	W	W1
	(mm)	1.75 ± 0.10	3.50 ± 0.05	4.00 ± 0.10	4.00 ± 0.10	2.00 ± 0.05	8.00 ± 0.30	14.4 MAX.
	(inch)	0.069 ± 0.004	0.138 ± 0.002	0.157 ± 0.004	0.157 ± 0.004	0.079 ± 0.002	0.315 ± 0.012	0.567 MAX.

Marking Code

Part Number	Marking Code
CDBV3-54-HF	KL5 , B4
CDBV3-54A-HF	KL6 , B7
CDBV3-54C-HF	KL7 , 5C
CDBV3-54S-HF	KL8 , B8

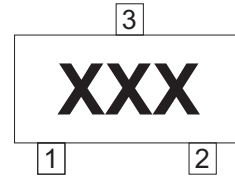

xxx = Product type marking code

Suggested PAD Layout

SIZE	SOT-323	
	(mm)	(inch)
A	0.70	0.028
B	0.90	0.035
C	0.65	0.025
D	1.90	0.075
E	2.80	0.110

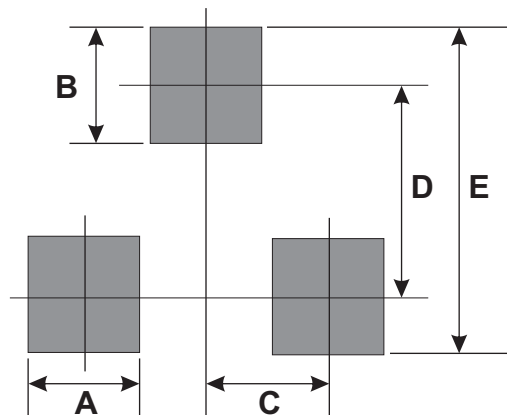

Standard Packaging

Case Type	REEL PACK	
	REEL (pcs)	Reel Size (inch)
SOT-323	3,000	7

X-ON Electronics

Largest Supplier of Electrical and Electronic Components

Click to view similar products for [Schottky Diodes & Rectifiers](#) category:

Click to view products by [Comchip](#) manufacturer:

Other Similar products are found below :

[MA4E2039](#) [MA4E2508M-1112](#) [MBR1545CT](#) [MMBD301M3T5G](#) [RB160M-50TR](#) [D83C](#) [BAS16E6433HTMA1](#) [BAT 54-02LRH E6327](#)
[NRVBAF360T3G](#) [NSR05F40QNXT5G](#) [NTE555](#) [JANS1N6640](#) [SK310-T](#) [SK34B-TP](#) [SS3003CH-TL-E](#) [GA01SHT18](#)
[CRS10I30A\(TE85L,QM](#) [MA4E2501L-1290](#) [MBRA140TRPBF](#) [MBRB30H30CT-1G](#) [BAT 15-04R E6152](#) [JANTX1N5712-1](#) [DMJ3940-000](#)
[SB007-03C-TB-E](#) [SK33B-TP](#) [NRVBB20100CTT4G](#) [NRVBM120LT1G](#) [NTSB30U100CT-1G](#) [VS-6CWQ10FNHM3](#) [CRG04\(T5L,TEMQ\)](#)
[ACDBA1100LR-HF](#) [ACDBA1200-HF](#) [ACDBA240-HF](#) [ACDBA3100-HF](#) [CDBQC0530L-HF](#) [CDBQC0240LR-HF](#) [ACDBA260LR-HF](#)
[ACDBA1100-HF](#) [MA4E2502L-1246](#) [10BQ015-M3/5BT](#) [NRVBM120ET1G](#) [CRS08TE85LQM](#) [PMAD1108-LF](#) [B120Q-13-F](#) [1N5819T-G](#)
[B0530WSQ-7-F](#) [PDS1040Q-13](#) [B160BQ-13-F](#) [SDM05U20CSP-7](#) [B140S1F-7](#)