

CGRMT4001-HF Thru. CGRMT4007-HF

Reverse Voltage: 50 to 1000 Volts

Forward Current: 1.0 Amp

RoHS Device

Halogen Free

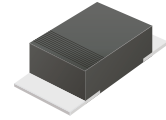

Features

- Excellent power dissipation offers better reverse leakage current and thermal resistance.
- Low profile package is 40% thinner than standards SOD-123 .
- Tiny plastic SMD package.
- High current capability.
- High surge capability.
- Glass passivated chip junction.
- Lead-free parts meet environmental standards of MIL-STD-19500/228

Mechanical data

- Epoxy: UL94-V0 rated flame retardant.
- Case: Molded plastic, SOD-123H/MINI SMA
- Terminals: Solderable per MIL-STD-750, Method 2026.
- Polarity: Indicated by cathode band.
- Mounting Position: any
- Weight: 0.011 grams approx.

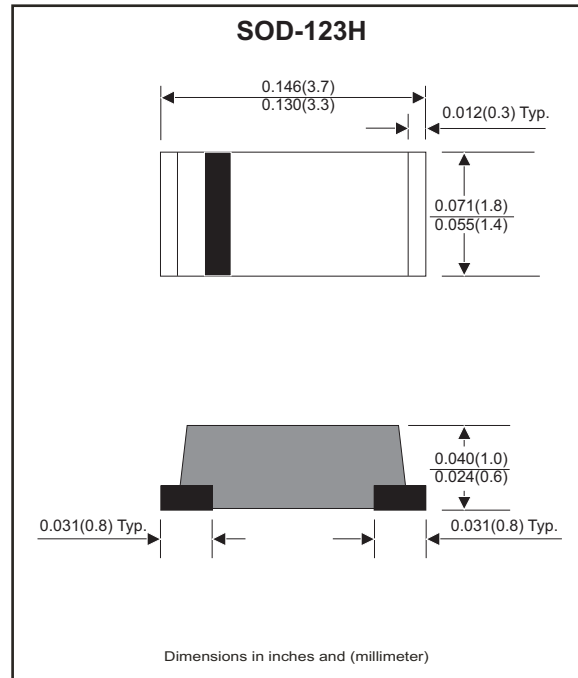

Maximum Ratings (at T_A=25°C unless otherwise noted)

Parameter	Symbol	CGRMT 4001-HF	CGRMT 4002-HF	CGRMT 4003-HF	CGRMT 4004-HF	CGRMT 4005-HF	CGRMT 4006-HF	CGRMT 4007-HF	Unit
Max. repetitive peak reverse voltage	V _{RRM}	50	100	200	400	600	800	1000	V
Max. Continuous reverse voltage	V _R	50	100	200	400	600	800	1000	V
Max. RMS voltage	V _{RMS}	35	70	140	280	420	560	700	V
Max. averaged forward current	I _o	1.0							A
Max. Forward voltage @ I _F =1.0A	V _F	1.1							V
Max. Forward surge current 8.3ms single half sine-wave superimposed on rated load (JEDEC method)	I _{FSM}	25							A
Max. Reverse current	V _R =V _{RRM} T _J =25°C	5.0							μA
	V _R =V _{RRM} T _J =100°C	50							
Typ. Thermal resistance, junction to ambient air	R _{θJA}	60							°C/W
Typ. Junction capacitance f=1MHz and applied 4V DC reverse voltage	C _J	15							pF
Operating junction temperature	T _J	-55 to +150							°C
Storage temperature range	T _{STG}	-65 to +175							°C

Rating and Characteristic Curves (CGRMT4001-HF Thru. CGRMT4007-HF)

Fig.1- Typical Forward Current Derating Curve

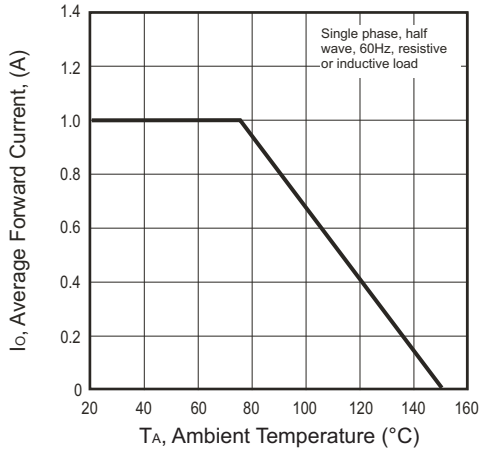

Fig.1- Typical Forward Characteristics

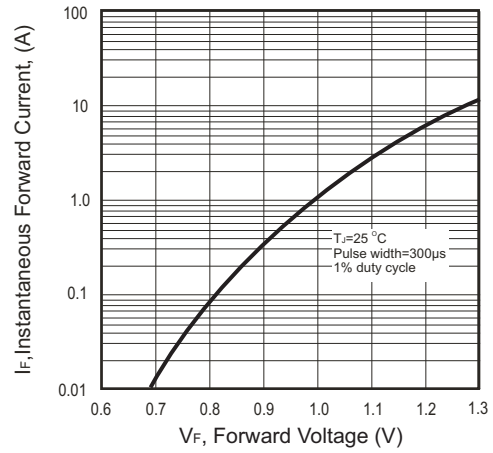

Fig.3- Typical Reverse Characteristics Forward Surge Current

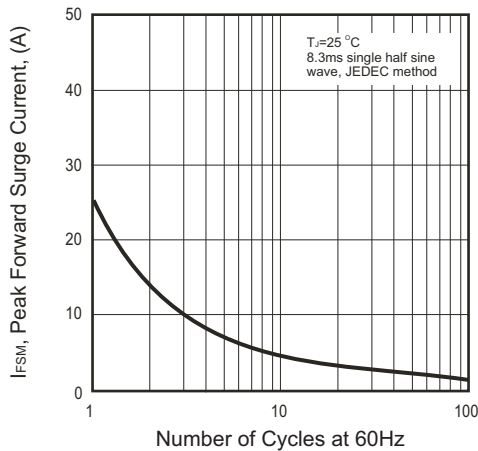

Fig.4- Typical Junction Capacitance

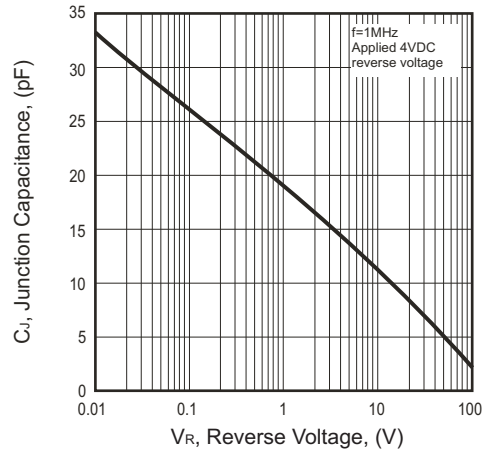
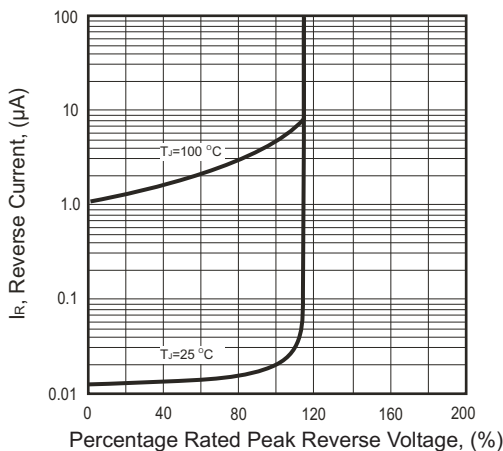
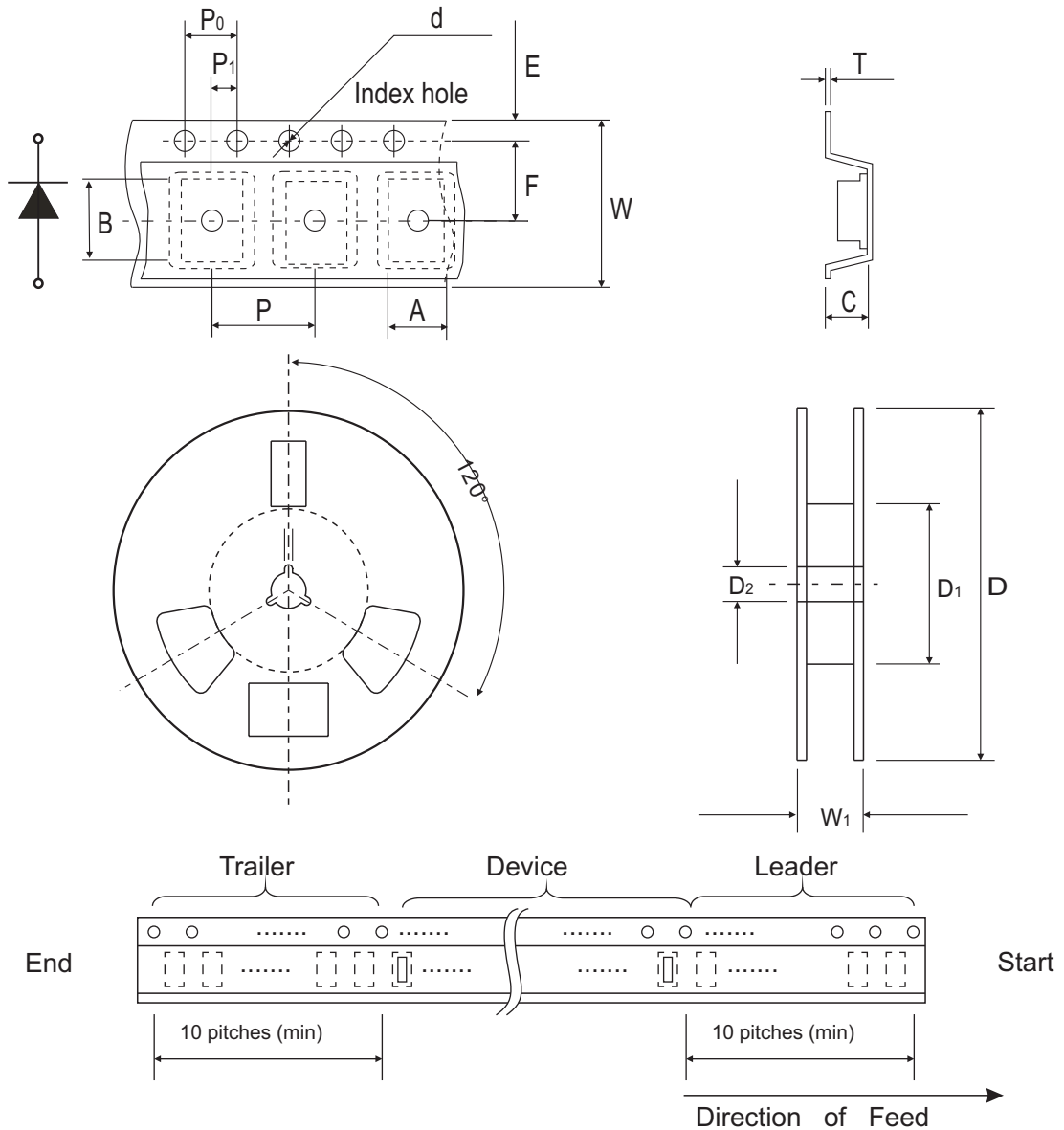

Fig.5- Maximum Non-repetitive





Reel Taping Specification



SOD-123H	SYMBOL	A	B	C	d	D	D1	D2
	(mm)	2.00 ± 0.10	3.85 ± 0.10	1.10 ± 0.10	1.50 ± 0.10	178 ± 2.00	62.0 MIN.	13.0 ± 0.50
	(inch)	0.079 ± 0.004	0.152 ± 0.004	0.043 ± 0.004	0.059 ± 0.004	7.00 ± 0.079	2.440 MIN.	0.512 ± 0.020

SOD-123H	SYMBOL	E	F	P	P0	P1	T	W	W1
	(mm)	1.75 ± 0.10	3.50 ± 0.10	4.00 ± 0.10	4.00 ± 0.10	2.00 ± 0.10	0.23 ± 0.10	8.00 ± 0.30	11.40 ± 1.0
	(inch)	0.069 ± 0.004	0.138 ± 0.004	0.157 ± 0.004	0.157 ± 0.004	0.079 ± 0.004	0.009 ± 0.004	0.315 ± 0.012	0.449 ± 0.039

Pinning information

Pin	Simplified outline	Symbol
PIN 1 Cathode PIN 2 Anode		

Marking Code

Part Number	Marking Code
CGRMT4001-HF	A1
CGRMT4002-HF	A2
CGRMT4003-HF	A3
CGRMT4004-HF	A4
CGRMT4005-HF	A5
CGRMT4006-HF	A6
CGRMT4007-HF	A7



xx = Product type marking code

Suggested PAD Layout

SIZE	SOD-123H	
	(mm)	(inch)
A	3.00	0.118
B	1.30	0.051
C	1.80	0.071
D	4.30	0.169
E	1.70	0.067

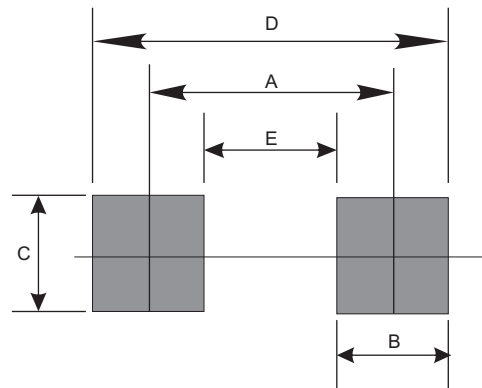

Standard Package

Case Type	REEL PACK (T/R)				
	REEL (EA)	BOX (EA)	CARTON (EA)	Reel Size (inch)	Type Mat'l
SOD-123H	3000	30000	240000	7	Plastic

X-ON Electronics

Largest Supplier of Electrical and Electronic Components

Click to view similar products for [Rectifiers](#) category:

Click to view products by [Comchip](#) manufacturer:

Other Similar products are found below :

[70HFR40](#) [RL252-TP](#) [150KR30A](#) [1N5397](#) [NTE5841](#) [NTE6038](#) [SCF5000](#) [1N4002G](#) [1N4005-TR](#) [JANS1N6640US](#) [481235F](#)
[RRE02VS6SGTR](#) [067907F](#) [MS306](#) [70HF40](#) [T110HF60](#) [T85HFL60S02](#) [US2JFL-TP](#) [A1N5404G-G](#) [CRS04\(T5L,TEMQ\)](#) [ACGRA4007-HF](#)
[ACGRB207-HF](#) [CLH03\(TE16L,Q\)](#) [ACGRC307-HF](#) [ACEFC304-HF](#) [NTE6356](#) [NTE6359](#) [NTE6002](#) [NTE6023](#) [NTE6039](#) [NTE6077](#)
[85HFR60](#) [40HFR60](#) [1N1186RA](#) [70HF120](#) [85HFR80](#) [D126A45C](#) [SCF7500](#) [D251N08B](#) [SCHJ22.5K](#) [SM100](#) [SCPA2](#) [SCH10000](#) [SDHD5K](#)
[VS-12FL100S10](#) [ACGRA4001-HF](#) [D1821SH45T PR](#) [D1251S45T](#) [NTE5990](#) [NTE6358](#)