

MMBT5401-HF (PNP)

RoHS Device

Halogen Free

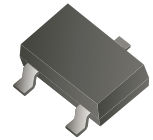

Features

- Power dissipation of 300mW.
- High stability and high reliability.

Mechanical data

- Case: SOT-23, molded plastic.
- Epoxy UL: 94V-0.
- Mounting position: Any.

Circuit Diagram

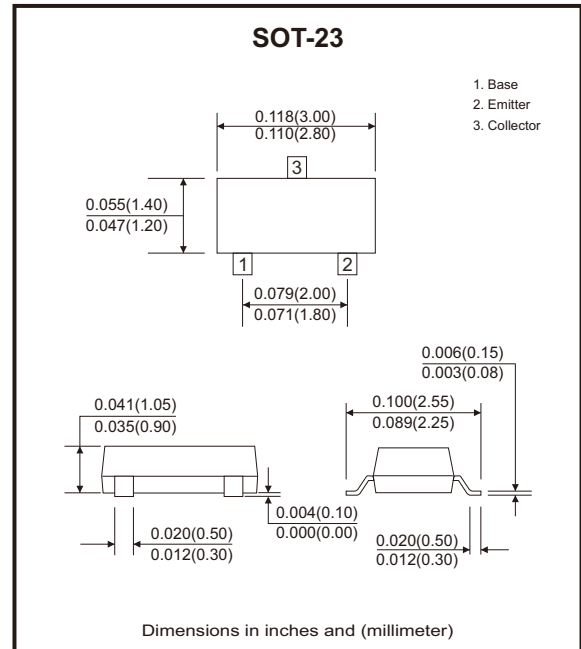
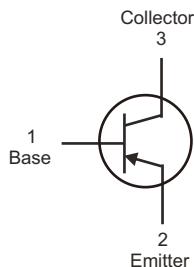

Maximum Ratings (at TA=25°C unless otherwise noted)

Parameter	Symbol	Value	Unit
Collector-base voltage	V _{CB0}	-160	V
Collector-emitter voltage	V _{CE0}	-150	V
Emitter-base voltage	V _{EB0}	-5	V
Collector current-continuous	I _c	-600	mA
Collector power dissipation	P _c	300	mW
Junction temperature	T _J	150	°C
Storage temperature range	T _{STG}	-55 to +150	°C
Thermal resistance from junction to ambient	R _{θJA}	416	°C/W

Electrical Characteristics (at TA=25°C unless otherwise noted)

Parameter	Symbol	Conditions	Min.	Typ.	Max.	Unit
Collector-base breakdown voltage	$V_{(BR)CBO}$	$I_C = -100\mu A, I_E = 0$	-160			V
Collector-emitter breakdown voltage (Note 1)	$V_{(BR)CEO}$	$I_C = -1mA, I_B = 0$	-150			V
Emitter-base breakdown voltage	$V_{(BR)EBO}$	$I_E = -10\mu A, I_C = 0$	-5			V
Collector cut-off current	I_{CBO}	$V_{CB} = -120V, I_E = 0$			-100	nA
Emitter cut-off current	I_{EBO}	$V_{EB} = -4V, I_C = 0$			-100	nA
DC current gain (Note 1)	$h_{FE(1)}$	$V_{CE} = -5V, I_C = -1mA$	80			
	$h_{FE(2)}$	$V_{CE} = -5V, I_C = -10mA$	100		300	
	$h_{FE(3)}$	$V_{CE} = -5V, I_C = -50mA$	30			
Collector-emitter saturation voltage (Note 1)	$V_{CE(sat)}$	$I_C = -10mA, I_B = -1mA$			-0.2	V
		$I_C = -50mA, I_B = -5mA$			-0.5	V
Base-emitter saturation voltage (Note 1)	$V_{BE(sat)}$	$I_C = -10mA, I_B = -1mA$			-1.00	V
		$I_C = -50mA, I_B = -5mA$			-1.00	V
Transition frequency	f_T	$V_{CE} = -5V, I_C = 10mA, f = 30MHz$	100			MHz

Notes: 1. Pulse test: pulse width $\leq 300\mu s$, duty cycle $\leq 2\%$.

Classification of $h_{FE(2)}$

h_{FE}	100-300	
Rank	L	H
Range	100-200	200-300

Rating and Characteristic Curves (MMBT5401-HF)

Fig.1 - Static Characteristic

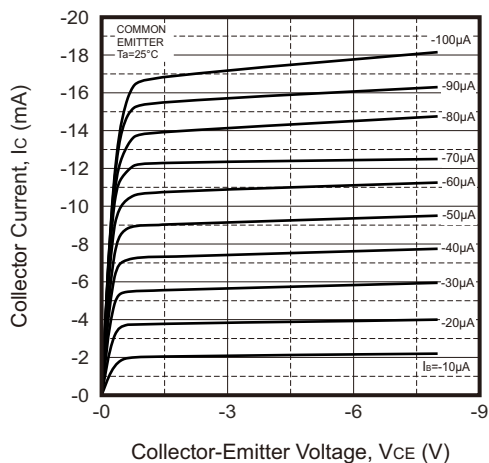
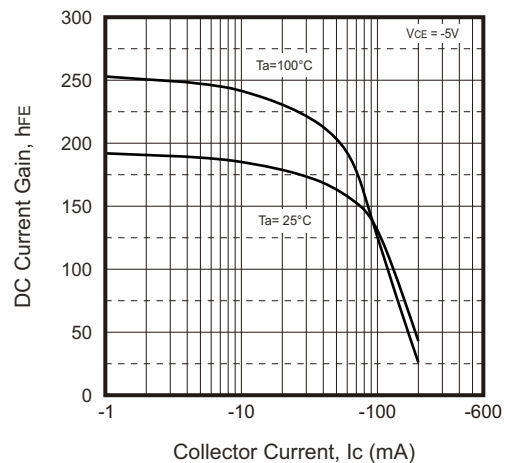

Fig.2 - $h_{FE} - I_C$



Rating and Characteristic Curves (MMBT5401-HF)

Fig.3 - V_{BEsat} — I_c

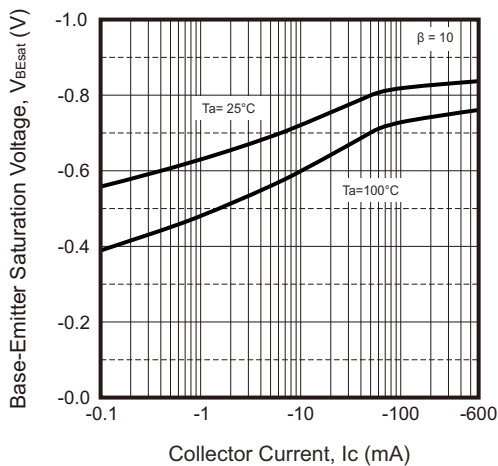

Fig.4 - V_{CEsat} — I_c

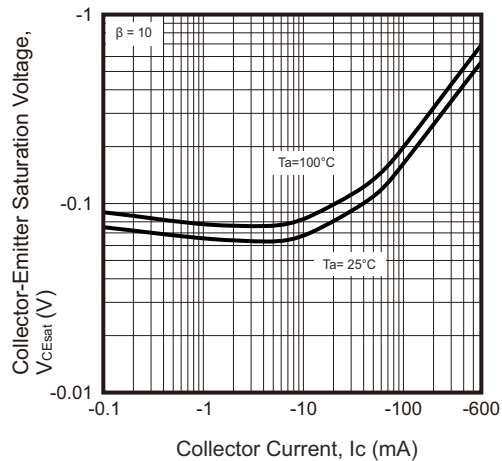

Fig.5 - I_c — V_{BE}

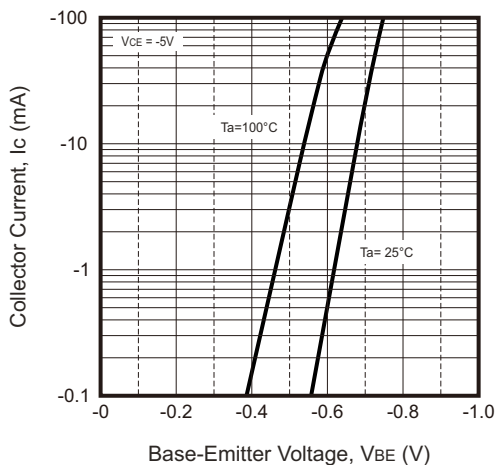

Fig.6 - C_{ob}/C_{ib} — V_{CB}/V_{EB}

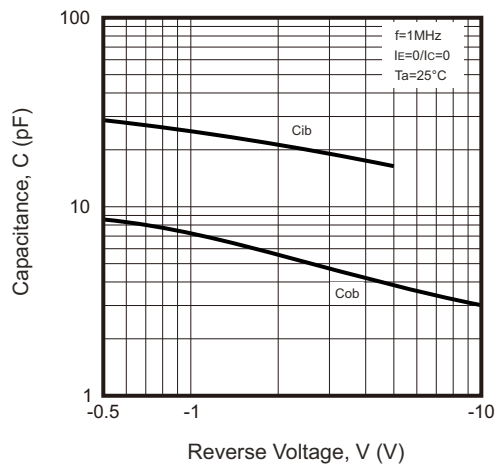

Fig.7 - f_T — I_c

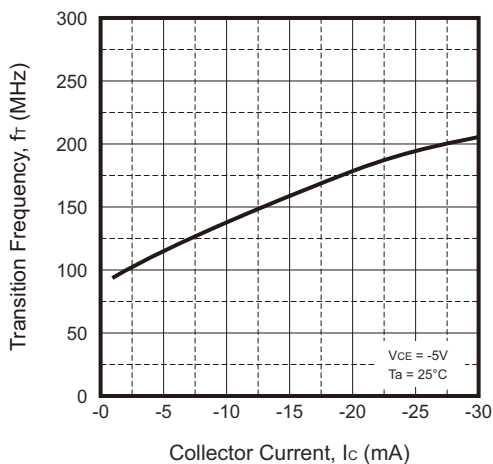
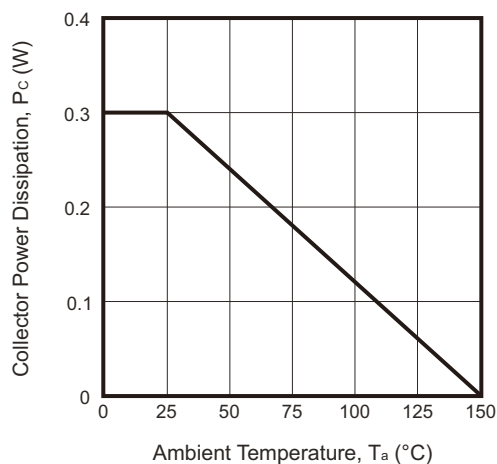
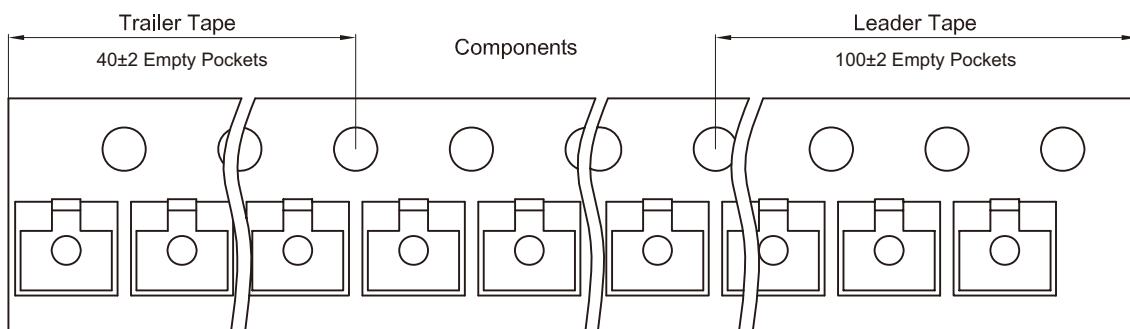
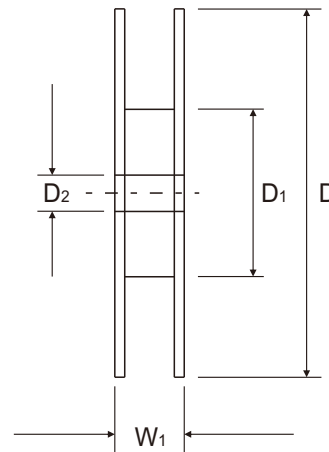
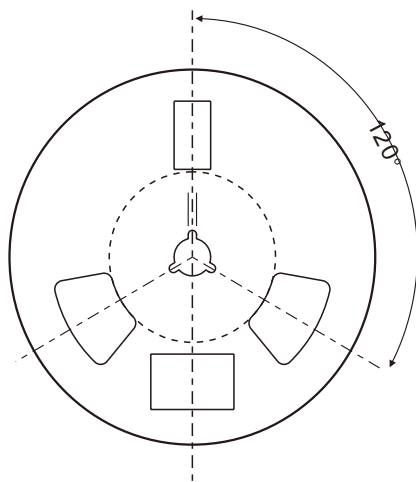
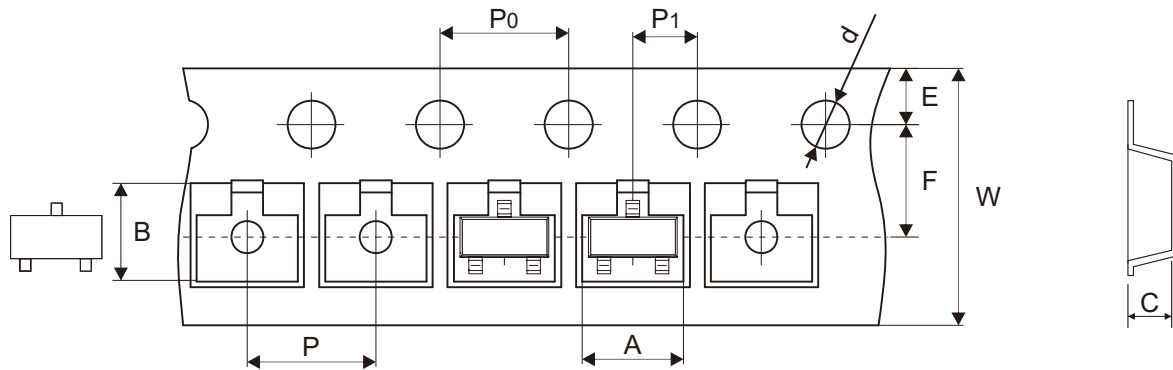

Fig.8 - P_c — T_a



Reel Taping Specification



SOT-23	SYMBOL	A	B	C	d	D	D1	D2
	(mm)	3.15 ± 0.10	2.77 ± 0.10	1.22 ± 0.10	1.50 ± 0.10	178.00 ± 2.00	54.40 ± 1.00	13.00 ± 1.00
	(inch)	0.124 ± 0.004	0.109 ± 0.004	0.048 ± 0.004	0.059 ± 0.004	7.008 ± 0.079	2.142 ± 0.039	0.512 ± 0.039

SOT-23	SYMBOL	E	F	P	P0	P1	W	W1
	(mm)	1.75 ± 0.10	3.50 ± 0.10	4.00 ± 0.10	4.00 ± 0.10	2.00 ± 0.10	8.00 ± 0.10	12.30 ± 1.00
	(inch)	0.069 ± 0.004	0.138 ± 0.004	0.157 ± 0.004	0.157 ± 0.004	0.079 ± 0.004	0.315 ± 0.004	0.484 ± 0.039

Marking Code

Part Number	Marking Code
MMBT5401-HF	2L

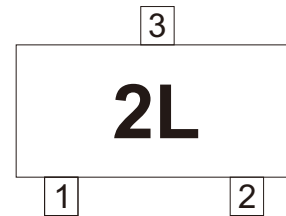

Suggested PAD Layout

SIZE	SOT-23	
	(mm)	(inch)
A	0.90	0.035
B	0.80	0.031
C	0.95	0.037
D	2.00	0.079
E	2.90	0.114

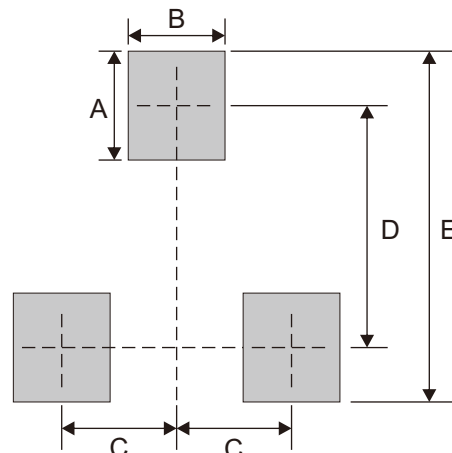

Note: 1. The pad layout is for reference purposes only.

Standard Packaging

Case Type	REEL PACK	
	REEL (pcs)	Reel Size (inch)
SOT-23	3,000	7

X-ON Electronics

Largest Supplier of Electrical and Electronic Components

Click to view similar products for [Bipolar Transistors - BJT category](#):

Click to view products by [Comchip manufacturer](#):

Other Similar products are found below :

[619691C](#) [MCH4017-TL-H](#) [BC546/116](#) [BC557/116](#) [BSW67A](#) [NTE158](#) [NTE187A](#) [NTE195A](#) [NTE2302](#) [NTE2330](#) [NTE63](#) [C4460](#)
[2SA1419T-TD-H](#) [2SA1721-O\(TE85L,F\)](#) [2SA2126-E](#) [2SB1204S-TL-E](#) [2SD2150T100R](#) [SP000011176](#) [FMMTA92QTA](#) [2N2369ADCSM](#)
[2N5769](#) [2SC2412KT146S](#) [2SC5490A-TL-H](#) [2SD1816S-TL-E](#) [2SD1816T-TL-E](#) [CMXT2207 TR](#) [CPH6501-TL-E](#) [MCH4021-TL-E](#)
[US6T6TR](#) [NJL0281DG](#) [732314D](#) [CMXT3906 TR](#) [CPH3121-TL-E](#) [CPH6021-TL-H](#) [873787E](#) [IMZ2AT108](#) [UMX21NTR](#) [MCH6102-TL-E](#)
[NJL0302DG](#) [2N3583](#) [2SA1434-TB-E](#) [2SC3143-4-TB-E](#) [2SD1621S-TD-E](#) [NTE103](#) [30A02MH-TL-E](#) [NSV40301MZ4T1G](#) [NTE101](#) [NTE13](#)
[NTE15](#) [NTE16001](#)