

## S1T-HF Thru. S1Y-HF

Reverse Voltage: 1300 to 2000 V

Forward Current: 1.0 A

RoHS Device  
Halogen Free



### Features

- Glass Passivated Die Construction
- Low Forward Voltage Drop and High Current Capability
- Surge Overload Rating to 30A Peak
- Ideally Suited for Automated Assembly
- Available in Lead Free Version

### Circuit diagram

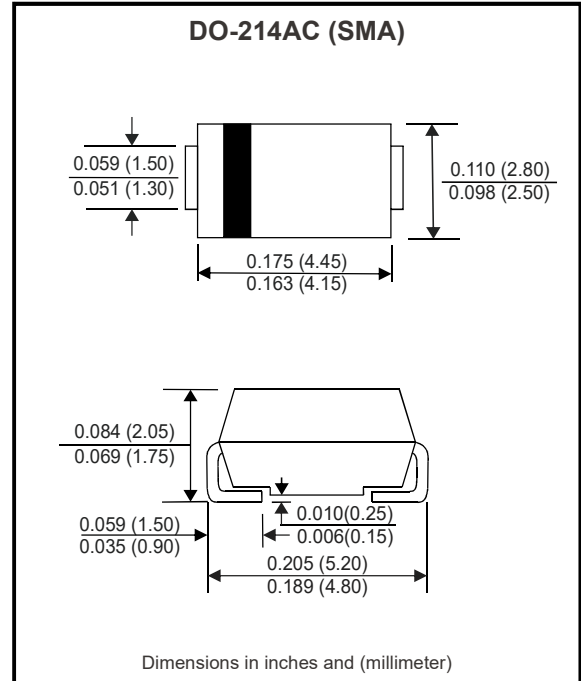

### Maximum Ratings and Electrical Characteristics

Parameter	Symbol	S1T-HF	S1W-HF	S1Y-HF	Units
Repetitive peak reverse voltage	$V_{RRM}$	1300	1600	2000	V
DC blocking voltage	$V_R$	1300	1600	2000	V
RMS voltage	$V_{RMS}$	910	1120	1400	V
Peak forwardsurge current: 8.3ms single half sine-wave superimposed on rated load	$I_{FSM}$		30.0		A
Average forward current	$I_{F(AV)}$		1.0		A
Forward voltage at 1.0A	$V_F$		1.1		V
DC reverse current	$I_R$	$T_J=25^{\circ}C$	5		$\mu A$
DC blocking voltage		$T_J=125^{\circ}C$	100		
Typical thermal resistance	$R_{\theta JC}$		30		$^{\circ}C/W$
Operating temperature range	$T_J$		-65 to +150		$^{\circ}C$
Storage temperature range	$T_{STG}$		-65 to +150		$^{\circ}C$

Notes: 1. P.C.B mounted with 0.2x0.2" (5.0x5.0mm) copper pad areas.  
2. Measured at 1.0 MHz and applied reverse voltage of 4.0 V DC.

Fig.1 - Forward Current Derating Curve

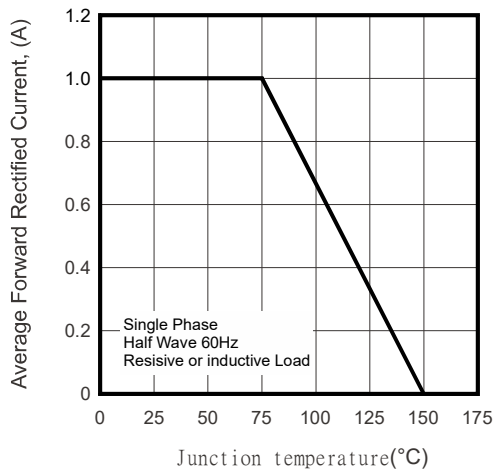
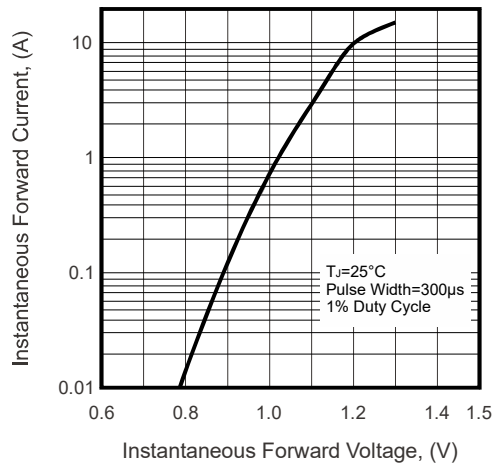
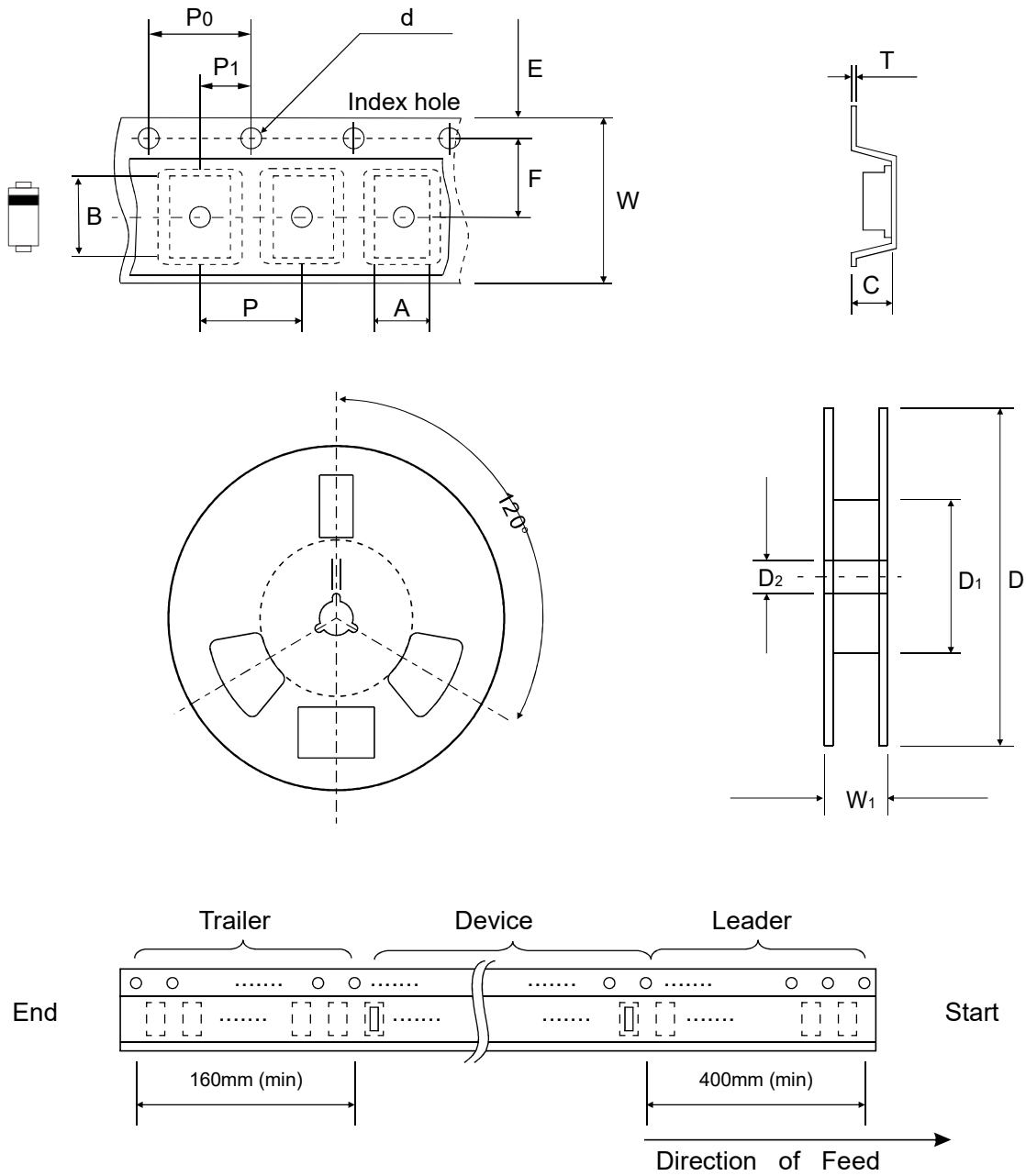

Fig.2 - Typical Instantaneous Forward Characteristics



## Reel Taping Specification



DO-214AC (SMA)	SYMBOL	A	B	C	d	D	D1	D2
	(mm)	2.80 ± 0.10	5.33 ± 0.10	2.36 ± 0.10	1.55 ± 0.10	330 ± 2.00		13.50 ± 2.00
	(inch)	0.110 ± 0.004	0.210 ± 0.004	0.093 ± 0.004	0.061 ± 0.004	12.992 ± 0.079		0.531 ± 0.079

DO-214AC (SMA)	SYMBOL	E	F	P	P0	P1	W	W1	T
	(mm)	1.75 ± 0.10	5.50 ± 0.10	4.00 ± 0.10	4.00 ± 0.10	2.00 ± 0.10	12.00 ± 0.10		0.25 ± 0.10
	(inch)	0.069 ± 0.004	0.217 ± 0.004	0.157 ± 0.004	0.157 ± 0.004	0.079 ± 0.004	0.472 ± 0.004		0.010 ± 0.004

Company reserves the right to improve product design , functions and reliability without notice.

REV:A

## Marking Code

Part Number	Marking code
S1T-HF	S1T
S1W-HF	S1W
S1Y-HF	S1Y

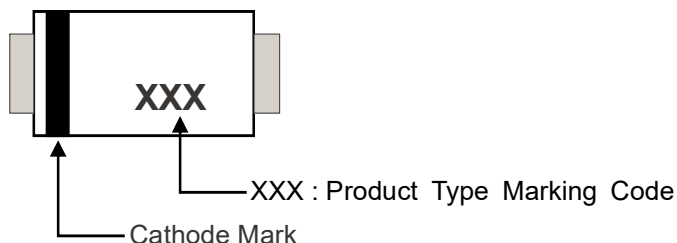

## Suggested PAD Layout

SIZE	DO-214AC (SMA)	
	(mm)	(inch)
A	4.00	0.157
B	2.50	0.100
C	1.80	0.071
D	6.50	0.256
E	1.50	0.060

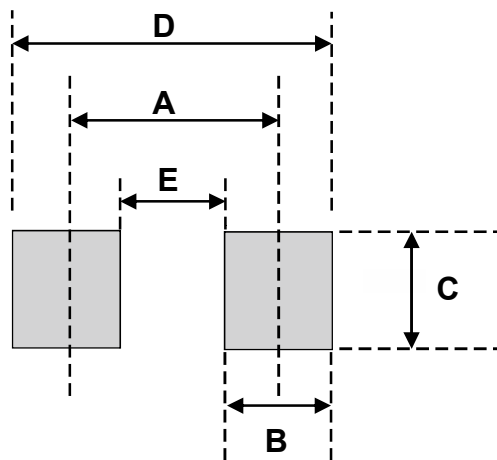

## Standard Packaging

Case Type	REEL PACK	
	REEL ( pcs )	Reel Size (inch)
DO-214AC (SMA)	5,000	13

## X-ON Electronics

Largest Supplier of Electrical and Electronic Components

*Click to view similar products for [Rectifiers](#) category:*

*Click to view products by [Comchip](#) manufacturer:*

Other Similar products are found below :

[70HFR40](#) [FR105 R0](#) [RL252-TP](#) [1N5397](#) [JANTX1N5634A](#) [1N4005-TR](#) [1N4007-BP](#) [UFS120Je3/TR13](#) [20ETS12S](#) [RRE02VS6SGTR](#)  
[MS306](#) [A1N5404G-G](#) [CRF02\(T5L,TEMQ\)](#) [ACGRB207-HF](#) [CLH07\(TE16L,Q\)](#) [CLH03\(TE16L,Q\)](#) [1N5395-TP](#) [UES1302](#) [ACGRC307-HF](#)  
[ACEFC304-HF](#) [DZ-1380](#) [85HFR60](#) [40HFR60](#) [70HF120](#) [85HFR80](#) [SCF7500](#) [SM100](#) [ACGRA4001-HF](#) [SKN70/08](#) [SKR70/08](#) [NTE5819](#)  
[NTE5827](#) [NTE5828](#) [NTE5911](#) [NTE5915](#) [NTE6104](#) [NTE6163](#) [NTE6164](#) [NTE6165](#) [NTE6364](#) [TSD3G](#) [SET130312](#) [NRVUS110VT3G](#)  
[UES1106](#) [UES1306](#) [NRVUS240VT3G](#) [D5FE60-5063](#) [R4000GPS-TP](#) [D4015L56TP](#) [UES1306HR2](#)