

TV04A5V0-HF Thru. TV04A441-HF

Working Peak Reverse Voltage: 5.0 to 440 Volts

Power Dissipation: 400 Watts

RoHS Device
Halogen Free

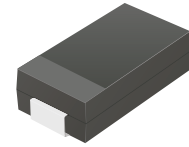

Features

- Glass passivated chip.
- 400W peak pulse power capability with a 10/1000 μ s waveform, repetitive rate (duty cycle):0.01%
- Low leakage.
- Uni and Bidirectional unit.
- Excellent clamping capability.
- Very fast response time.
- UL recognized file # E349157  Range: TV04A5V0J(B) thru. TV04A240J(B)

Mechanical data

- Epoxy: UL 94V-0 rate flame retardant.
- Case: SMA/DO-214AC, molded plastic.
- Terminals: solderable per MIL-STD-750, method 2026.
- Polarity: Color band denotes cathode end except bipolar.
- Weight: 0.069 gram (approx.)

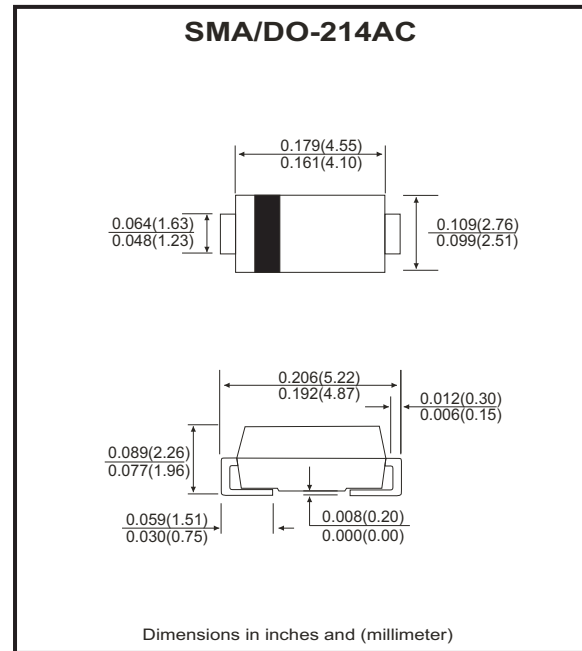

Maximum Ratings and Electrical Characteristics

Ratings at 25 °C ambient temperature unless otherwise specified.
Single phase, half wave, 60Hz, resistive or inductive load.
For capacitive load, derate current by 20%.

| Characteristics | Symbol | Value | Units |
|--|-----------------------------------|----------------|-------|
| Peak power dissipation on 10/1000 μ S waveform (Note1) | P _{PP} | 400 | W |
| Peak pulse current on 10/1000 μ S waveform (Note 1) | I _{PP} | See Next Table | A |
| Steady state power dissipation at T _L =75°C | P _D | 1.0 | W |
| Peak forward surge current, 8.3mS single half sine-wave unidirectional only (Note 2) | I _{FSM} | 40 | A |
| Maximum instantaneous forward voltage at 25.0A for unidirectional only (Note 3) | V _F | 3.5/5.0 | V |
| Operating junction and storage temperature | T _J , T _{STG} | -55 to +150 | °C |

Notes: 1. Non-repetitive current pulse, per Fig. 5 and derated above T_A=25°C, per Fig. 1.
2. Measured on 8.3mS single half sine-wave or equare wave,duty cycle=4 pulses per minute maximum.
3. V_F<3.5V for devices of V_{BR}<200V and V_F<5.0V for devices of V_{BR}>201V

RATING AND CHARACTERISTIC CURVES (TV04A5V0-HF thru TV04A441-HF)

Fig.1 - Pulse Derating Curve

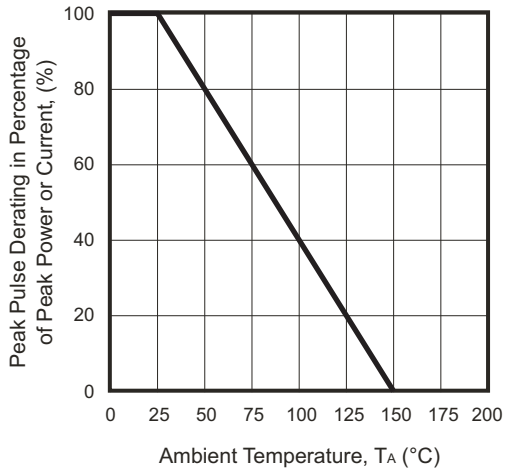

Fig.2 - Maximum Non-Repetitive Surge Current

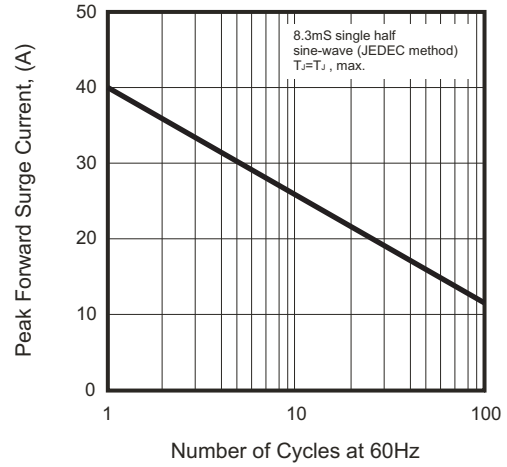

Fig.3 - Steady State Power Derating Curve

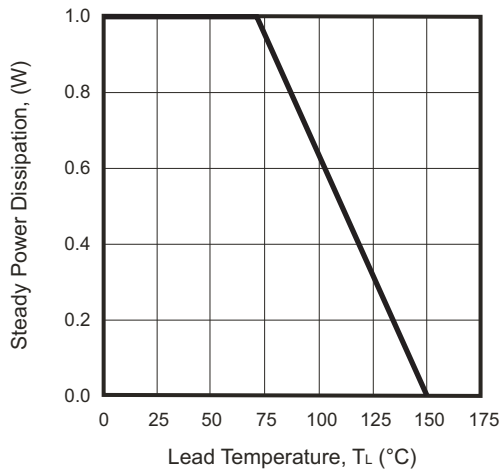

Fig.4 - Peak Pulse Power Rating Curve

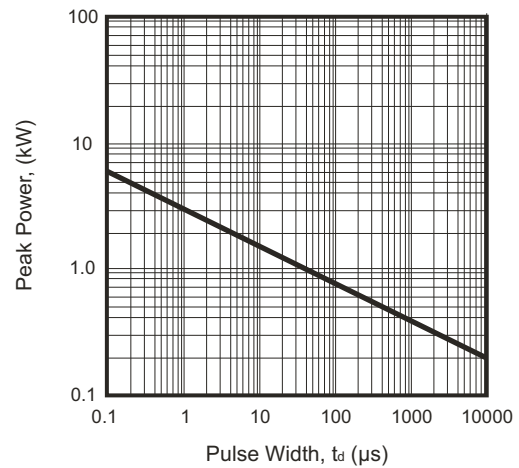

Fig.5 - Pulse Waveform

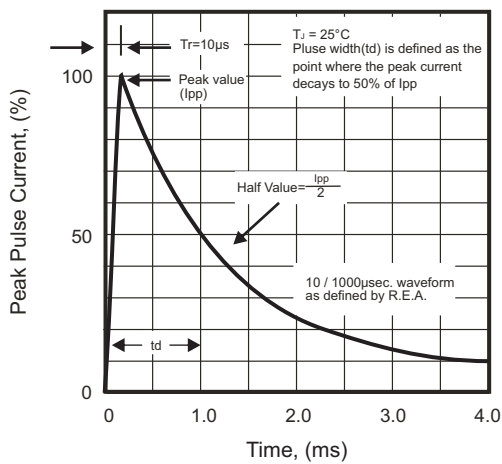
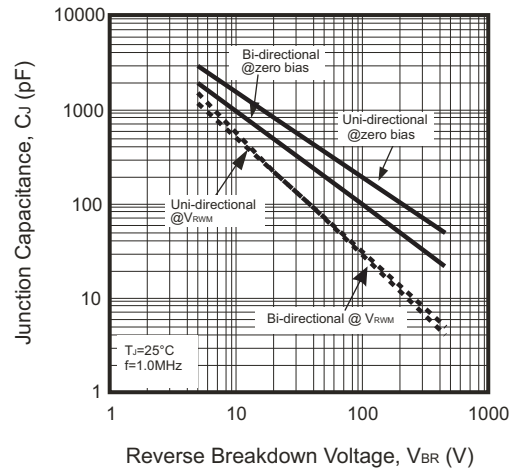

Fig.6 - Typical Junction Capacitance



SMD Transient Voltage Suppressor

Electrical Characteristics (TV04A5V0-HF Thru. TV04A441-HF)

| Part No. | Breakdown voltage V _{BR} @ I _T | | | Maximum Reverse Leakage @VRWM I _R (uA) | Working Peak Reverse Voltage VRWM (V) | Maximum Reverse Surge Current I _{PP} (A) | Maximum Clamping Voltage @I _{PP} V _c (V) | Device Marking Code | |
|-----------------|---|----------|---------------------|---|--|--|--|---------------------|----|
| | Min. (V) | Max. (V) | I _T (mA) | | | | | UNI | BI |
| TV04A5V0J(B)-HF | 6.40 | 7.00 | 10 | 800 | 5.0 | 43.48 | 9.2 | AE | WE |
| TV04A6V0J(B)-HF | 6.67 | 7.37 | 10 | 800 | 6.0 | 38.83 | 10.3 | AG | WG |
| TV04A6V5J(B)-HF | 7.22 | 7.98 | 10 | 500 | 6.5 | 35.71 | 11.2 | AK | WK |
| TV04A7V0J(B)-HF | 7.78 | 8.60 | 10 | 200 | 7.0 | 33.33 | 12.0 | AM | WM |
| TV04A7V5J(B)-HF | 8.33 | 9.21 | 1 | 100 | 7.5 | 31.01 | 12.9 | AP | WP |
| TV04A8V0J(B)-HF | 8.89 | 9.83 | 1 | 50 | 8.0 | 29.41 | 13.6 | AR | WR |
| TV04A8V5J(B)-HF | 9.44 | 10.40 | 1 | 10 | 8.5 | 27.78 | 14.4 | AT | WT |
| TV04A9V0J(B)-HF | 10.00 | 11.10 | 1 | 5 | 9.0 | 25.97 | 15.4 | AV | WV |
| TV04A100J(B)-HF | 11.10 | 12.30 | 1 | 5 | 10.0 | 23.53 | 17.0 | AX | WX |
| TV04A110J(B)-HF | 12.20 | 13.50 | 1 | 1 | 11.0 | 21.98 | 18.2 | AZ | WZ |
| TV04A120J(B)-HF | 13.30 | 14.70 | 1 | 1 | 12.0 | 20.10 | 19.9 | BE | XE |
| TV04A130J(B)-HF | 14.40 | 15.90 | 1 | 1 | 13.0 | 18.60 | 21.5 | BG | XG |
| TV04A140J(B)-HF | 15.60 | 17.20 | 1 | 1 | 14.0 | 17.24 | 23.2 | BK | XK |
| TV04A150J(B)-HF | 16.70 | 18.50 | 1 | 1 | 15.0 | 16.39 | 24.4 | BM | XM |
| TV04A160J(B)-HF | 17.80 | 19.70 | 1 | 1 | 16.0 | 15.38 | 26.0 | BP | XP |
| TV04A170J(B)-HF | 18.90 | 20.90 | 1 | 1 | 17.0 | 14.49 | 27.6 | BR | XR |
| TV04A180J(B)-HF | 20.00 | 22.10 | 1 | 1 | 18.0 | 13.70 | 29.2 | BT | XT |
| TV04A190J(B)-HF | 21.10 | 23.30 | 1 | 1 | 19.0 | 13.00 | 30.8 | BB | XB |
| TV04A200J(B)-HF | 22.20 | 24.50 | 1 | 1 | 20.0 | 12.35 | 32.4 | BV | XV |
| TV04A220J(B)-HF | 24.40 | 26.90 | 1 | 1 | 22.0 | 11.27 | 35.5 | BX | XX |
| TV04A240J(B)-HF | 26.70 | 29.50 | 1 | 1 | 24.0 | 10.28 | 38.9 | BZ | XZ |
| TV04A260J(B)-HF | 28.90 | 31.90 | 1 | 1 | 26.0 | 9.50 | 42.1 | CE | YE |
| TV04A280J(B)-HF | 31.10 | 34.40 | 1 | 1 | 28.0 | 8.81 | 45.4 | CG | YG |
| TV04A300J(B)-HF | 33.30 | 36.80 | 1 | 1 | 30.0 | 8.26 | 48.4 | CK | YK |
| TV04A330J(B)-HF | 36.70 | 40.60 | 1 | 1 | 33.0 | 7.50 | 53.3 | CM | YM |
| TV04A360J(B)-HF | 40.00 | 44.20 | 1 | 1 | 36.0 | 6.88 | 58.1 | CP | YP |
| TV04A400J(B)-HF | 44.40 | 49.10 | 1 | 1 | 40.0 | 6.20 | 64.5 | CR | YR |
| TV04A430J(B)-HF | 47.80 | 52.80 | 1 | 1 | 43.0 | 5.76 | 69.4 | CT | YT |
| TV04A450J(B)-HF | 50.00 | 55.30 | 1 | 1 | 45.0 | 5.50 | 72.7 | CV | YV |
| TV04A480J(B)-HF | 53.30 | 58.90 | 1 | 1 | 48.0 | 5.17 | 77.4 | CX | YX |
| TV04A510J(B)-HF | 56.70 | 62.70 | 1 | 1 | 51.0 | 4.85 | 82.4 | CZ | YZ |
| TV04A540J(B)-HF | 60.00 | 66.30 | 1 | 1 | 54.0 | 4.59 | 87.1 | RE | ZE |
| TV04A580J(B)-HF | 64.40 | 71.20 | 1 | 1 | 58.0 | 4.27 | 93.6 | RG | ZG |
| TV04A600J(B)-HF | 66.70 | 73.70 | 1 | 1 | 60.0 | 4.13 | 96.8 | RK | ZK |
| TV04A640J(B)-HF | 71.10 | 78.60 | 1 | 1 | 64.0 | 3.88 | 103.0 | RM | ZM |
| TV04A700J(B)-HF | 77.80 | 86.00 | 1 | 1 | 70.0 | 3.54 | 113.0 | RP | ZP |
| TV04A750J(B)-HF | 83.30 | 92.10 | 1 | 1 | 75.0 | 3.31 | 121.0 | RR | ZR |
| TV04A780J(B)-HF | 86.70 | 95.80 | 1 | 1 | 78.0 | 3.17 | 126.0 | RT | ZT |
| TV04A800J(B)-HF | 88.80 | 97.60 | 1 | 1 | 80.0 | 3.09 | 129.6 | RB | ZB |
| TV04A850J(B)-HF | 94.40 | 104.00 | 1 | 1 | 85.0 | 2.92 | 137.0 | RV | ZV |

Company reserves the right to improve product design , functions and reliability without notice.

REV:F

Electrical Characteristics (TV04A5V0-HF Thru. TV04A441-HF)

| Part No. | Breakdown voltage V _{BR} @ I _T | | | Maximum Reverse Leakage @V _{RWM} I _R (uA) | Working Peak Reverse Voltage V _{RWM} (V) | Maximum Reverse Surge Current I _{PP} (A) | Maximum Clamping Voltage @I _{PP} V _C (V) | Device Marking Code | |
|-----------------|---|-------------|------------------------|---|---|---|--|---------------------------|----|
| | Min. (V) | Max. (V) | I _T (mA) | | | | | UNI | BI |
| TV04A900J(B)-HF | 100.0 | 111.0 | 1 | 1 | 90.0 | 2.74 | 146.0 | RX | ZX |
| TV04A101J(B)-HF | 111.0 | 123.0 | 1 | 1 | 100.0 | 2.47 | 162.0 | RZ | ZZ |
| TV04A111J(B)-HF | 122.0 | 135.0 | 1 | 1 | 110.0 | 2.26 | 177.0 | SE | VE |
| TV04A121J(B)-HF | 133.0 | 147.0 | 1 | 1 | 120.0 | 2.07 | 193.0 | SG | VG |
| TV04A131J(B)-HF | 144.0 | 159.0 | 1 | 1 | 130.0 | 1.91 | 209.0 | SK | VK |
| TV04A141J(B)-HF | 155.0 | 171.0 | 1 | 1 | 140.0 | 1.76 | 226.8 | SB | VB |
| TV04A151J(B)-HF | 167.0 | 185.0 | 1 | 1 | 150.0 | 1.65 | 243.0 | SM | VM |
| TV04A161J(B)-HF | 178.0 | 197.0 | 1 | 1 | 160.0 | 1.54 | 259.0 | SP | VP |
| TV04A171J(B)-HF | 189.0 | 209.0 | 1 | 1 | 170.0 | 1.45 | 275.0 | SR | VR |
| TV04A181J(B)-HF | 200.0 | 220.0 | 1 | 1 | 180.0 | 1.37 | 291.6 | ST | VT |
| TV04A191J(B)-HF | 211.0 | 232.0 | 1 | 1 | 190.0 | 1.30 | 307.8 | SV | VV |
| TV04A201J(B)-HF | 224.0 | 247.0 | 1 | 1 | 200.0 | 1.23 | 324.0 | SW | VW |
| TV04A221J(B)-HF | 246.0 | 272.0 | 1 | 1 | 220.0 | 1.12 | 356.0 | SX | VX |
| TV04A251J(B)-HF | 279.0 | 309.0 | 1 | 1 | 250.0 | 0.99 | 405.0 | SZ | VZ |
| TV04A301J(B)-HF | 335.0 | 371.0 | 1 | 1 | 300.0 | 0.82 | 486.0 | DE | HE |
| TV04A351J(B)-HF | 391.0 | 432.0 | 1 | 1 | 350.0 | 0.71 | 567.0 | DG | HG |
| TV04A401J(B)-HF | 447.0 | 494.0 | 1 | 1 | 400.0 | 0.62 | 648.0 | DK | HK |
| TV04A441J(B)-HF | 492.0 | 543.0 | 1 | 1 | 440.0 | 0.56 | 713.0 | DM | HM |

Note:

- 1) Suffix J denotes 5% tolerance devices.
- 2) Suffix B after part number to specify Bi-directional devices.
- 3) For Bi-Directional devices having V_R of 10 volts and under, the I_R limit is double.

Reel Taping Specification

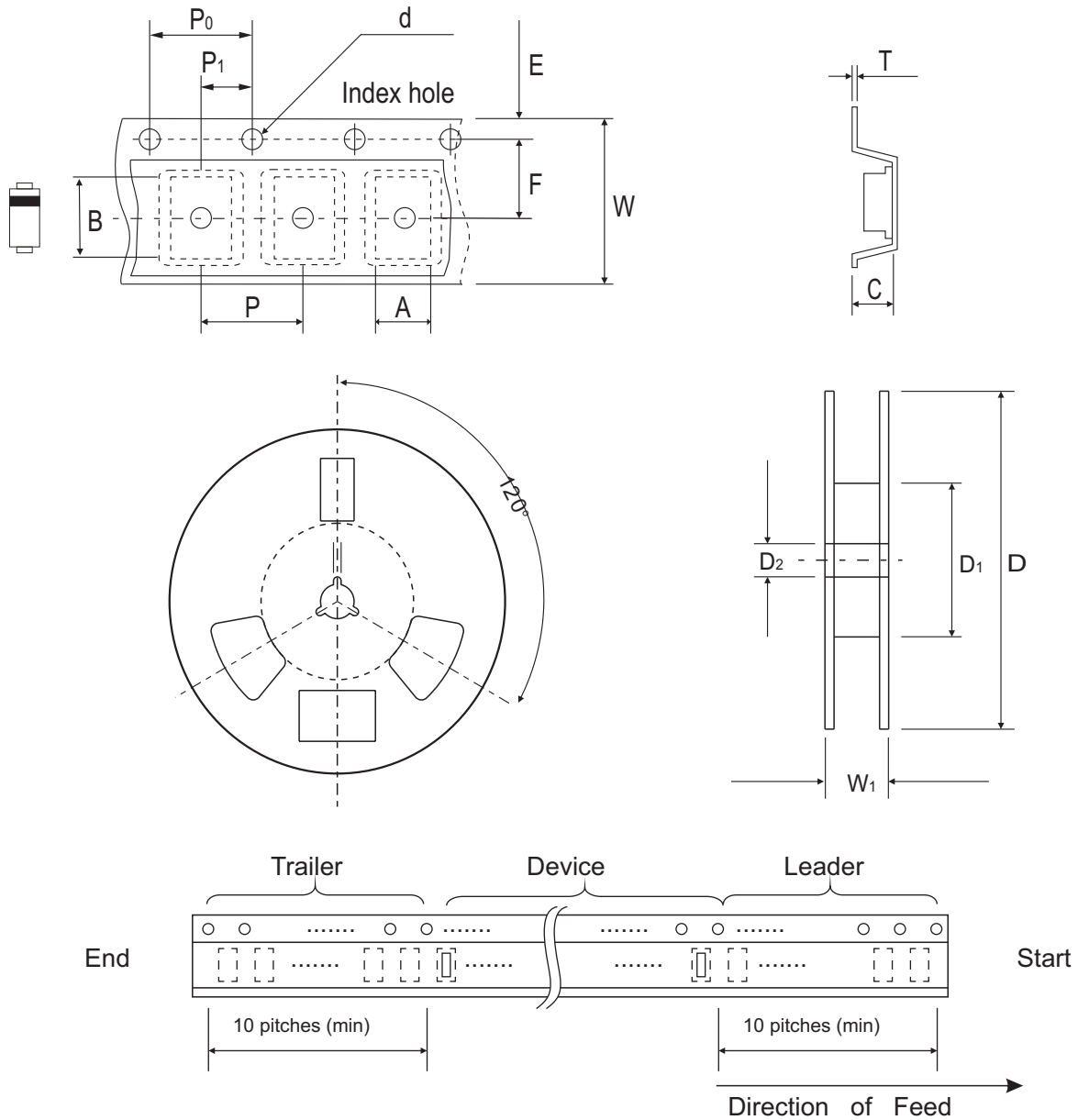

| SMA/DO-214AC | SYMBOL | A | B | C | d | D | D1 | D2 |
|--------------|--------|---------------|---------------|-------------|---------------|----------|------------|---------------|
| | (mm) | 2.79 ± 0.10 | 5.33 ± 0.10 | 4.50 (max) | 1.75 ± 0.10 | 330MAX | 50.0 MIN. | 13.0 ± 0.2 |
| | (inch) | 0.110 ± 0.004 | 0.210 ± 0.004 | 0.177 (max) | 0.069 ± 0.004 | 13.00MAX | 1.969 MIN. | 0.512 ± 0.008 |

| SMA/DO-214AC | SYMBOL | E | F | P | P0 | P1 | W | W1 |
|--------------|--------|---------------|---------------|---------------|---------------|---------------|---------------|------------|
| | (mm) | 1.75 ± 0.10 | 5.50 ± 0.05 | 4.00 ± 0.10 | 4.00 ± 0.10 | 2.00 ± 0.05 | 12.0 ± 0.30 | 18.4 MAX. |
| | (inch) | 0.069 ± 0.004 | 0.216 ± 0.002 | 0.157 ± 0.004 | 0.157 ± 0.004 | 0.079 ± 0.002 | 0.472 ± 0.012 | 0.724 MAX. |

Company reserves the right to improve product design, functions and reliability without notice.

REV:F

Marking Code

1. **C**: COMCHIP

2. ○: Package

| | |
|---|-----|
| ○ | PKG |
| A | SMA |
| B | SMB |
| C | SMC |

3. **XX**: Marking code (see Page. 3~4)

4. **█**: Cathod Band

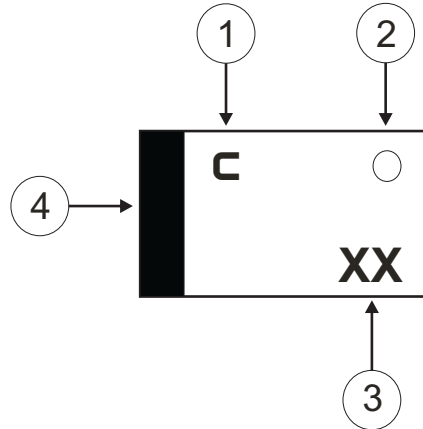

Suggested PAD Layout

| SIZE | DO-214AC(SMA) | |
|------|---------------|-----------|
| | (mm) | (inch) |
| A | 5.28 | 0.208 |
| B | 1.88 MAX | 0.074 MAX |
| C | 1.52 MIN | 0.060 MIN |
| D | 1.68 MIN | 0.066 MIN |

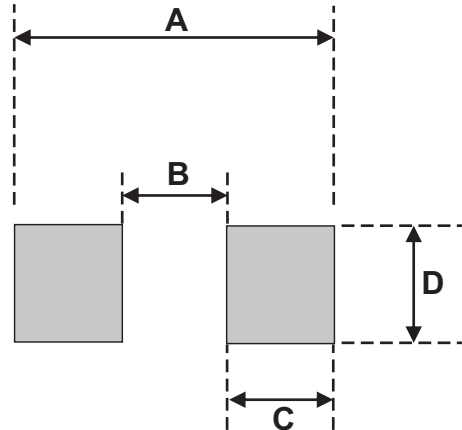

Standard Packaging

| Case Type | REEL PACK | |
|--------------|--------------|------------------|
| | REEL (pcs) | Reel Size (inch) |
| SMA/DO-214AC | 5,000 | 13 |

X-ON Electronics

Largest Supplier of Electrical and Electronic Components

Click to view similar products for [ESD Suppressors / TVS Diodes](#) category:

Click to view products by [Comchip](#) manufacturer:

Other Similar products are found below :

[60KS200C](#) [D12V0H1U2WS-7](#) [D18V0L1B2LP-7B](#) [82356050220](#) [D5V0M5U6V-7](#) [NTE4902](#) [P4KE27CA](#) [P6KE11CA](#) [P6KE39CA-TP](#)
[P6KE8.2A](#) [SA110CA](#) [SA60CA](#) [SA64CA](#) [SMBJ12CATR](#) [SMBJ8.0A](#) [SMLJ30CA-TP](#) [ESD101-B1-02ELS E6327](#) [ESD112-B1-02EL E6327](#)
[ESD119B1W01005E6327XTSA1](#) [ESD5V0L1B02VH6327XTSA1](#) [ESD7451N2T5G](#) [19180-510](#) [CPDT-5V0USP-HF](#) [3.0SMCJ33CA-F](#)
[3.0SMCJ36A-F](#) [HSPC16701B02TP](#) [D3V3Q1B2DLP3-7](#) [D55V0M1B2WS-7](#) [DESD5V0U1BL-7B](#) [DRTR5V0U4SL-7](#) [SCM1293A-04SO](#)
[ESD200-B1-CSP0201 E6327](#) [ESD203-B1-02EL E6327](#) [SM12-7](#) [SMF8.0A-TP](#) [SMLJ45CA-TP](#) [CEN955 W/DATA](#) [82350120560](#)
[82356240030](#) [VESD12A1A-HD1-GS08](#) [CPDUR5V0R-HF](#) [CPDUR24V-HF](#) [CPDQC5V0U-HF](#) [CPDQC5V0USP-HF](#) [CPDQC5V0-HF](#)
[D1213A-01LP4-7B](#) [D1213A-02WL-7](#) [ESDLIN1524BJ-HQ](#) [5KP100A](#) [5KP15A](#)