

NOTES:

1. RECOMMENDED SOLDER INSTRUCTION SEE SHEET 2
2. IP RATING: IP 67
3. SEALED TO WITHSTAND PRESSURE UP TO 1,45 PSI FOR 30 MINUTES AFTER SOLDERING
4. METALSHELL: ZINC DIE CAST; min. 50µin NICKEL PLATING over COPPER
5. INSULATORS: PBT GF UL 94 V-0, BLACK
6. O-RING: SILICONE PER ASTM D2000 70 SHORE A
7. RUBBER GASKET: TPE
8. SEALING COMPOUND: EPOXY RESIN UL 94 V-0; BLACK
9. CONTACTS: COPPER ALLOY
PLATING (SEE PART NO):
 PLEASE ADD 1 for 30µin HARD GOLD over min. 50µin NICKEL
 PLEASE ADD 3 for 8µin HARD GOLD over min. 50µin NICKEL
 SOLDER CUP ACCEPTS CABLE AWG 22
10. HEXLOCKING SCREWS: STAINLESS STEEL
11. RECOMMENDED PANEL CUT-OUT ON SHEET 2
12. RECOMMENDED TORQUE FOR MOUNTING SCREW
35Ncm (3.1 in.LB) / max.67Ncm (6 in.LB)
13. CONNECTOR IS PART MARKED: 15-00065 CONEC ABC

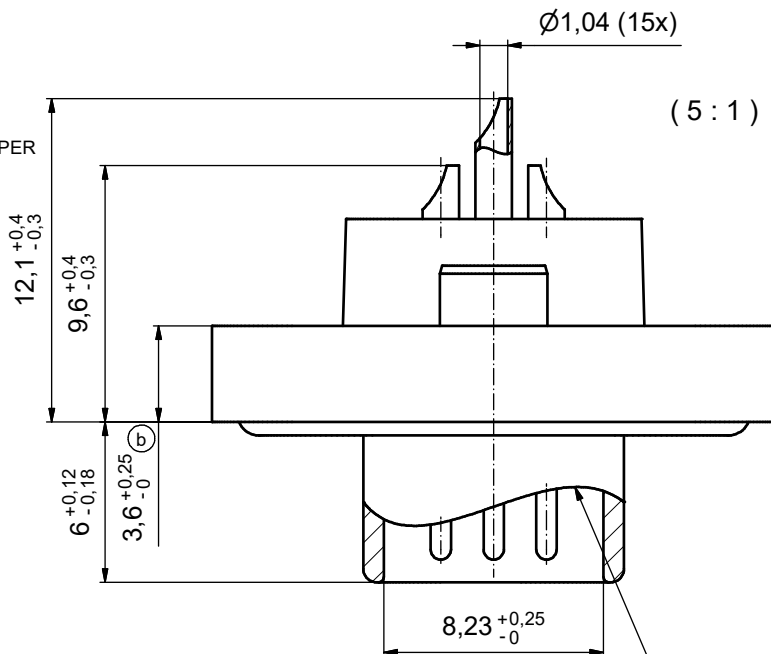

RUBBER GASKET
PLACED ON TOP SURFACE
OF MALE INSULATOR

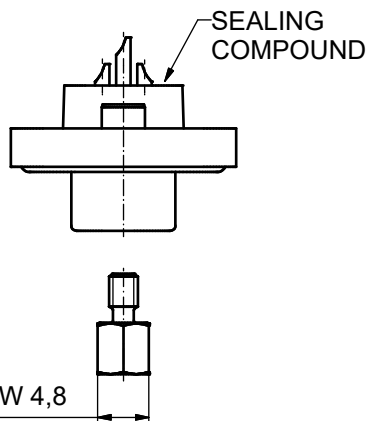
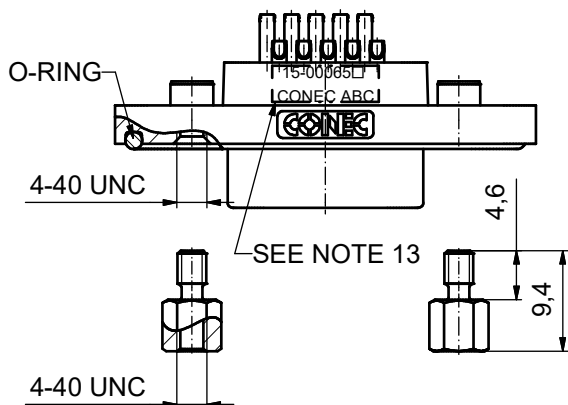
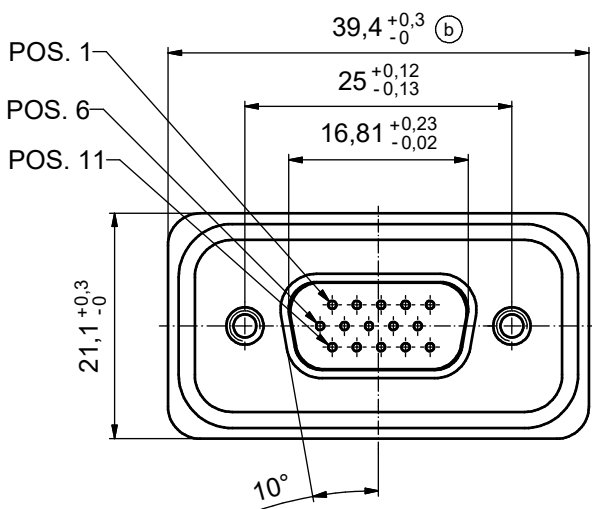
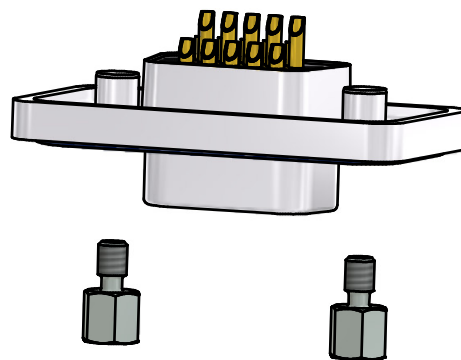

(b) AT ALL TIMES WATER RESISTANT CONNECTORS NOT IN USE SHOULD BE COVERED WITH A CONEC WATER RESISTANT CAP OR WATER TIGHT HOOD.

Directive 2002/95/EC RoHS compliant

APPROVAL # FREIGABE # DEBLOCAGE # AUTORIZACION # APPROVAL	
CUSTOMER APPROVAL DATE:	
NAME:	TITLE:
COMPANY NAME:	
APPROVAL # FREIGABE # DEBLOCAGE # AUTORIZACION # APPROVAL	

THIS DRAWING MAY NOT BE COPIED OR REPRODUCED IN ANY WAY, AND MAY NOT BE PASSED ON TO A THIRD PARTY WITHOUT WRITTEN PERMISSION. OWNERSHIP AND COPYRIGHT OF CONEC GmbH				tolerance		dim. in mm	
DO NOT ALTER CAD DRAWING BY HAND				date	name	scale: 2:1 (5:1)	
3 x b	A 3435	30.09.09	HS	drawn	17.10.08	Petker	material: see notes
a	Origin			appd.	23.10.08	Fischer	title: D-SUB MALE HD 15pos. SOLDER CUP with hexlocking screw
rev.	description	date	name	norm			dwg no: Inventor 10
				d-old			DIN-A3
				CONEC		part no: 15K1A280	
						part no: 15-00065 (see note 9)	

title: D-SUB MALE HD 15pos. SOLDER CUP with hexlocking screw	
dwg no: Inventor 10	DIN-A3
sh: 1	
part no: 15-00065 (see note 9)	

Solder Instruction

1. Cable should be prepared for soldering. The cable/wires must be pretinned.
2. Insert cable/wire into solder cup.
3. Operate the soldering iron at 350°C, 50 Watt max. and use a pencil tip.
4. Put tip to wire in solder cup.
5. After 1 second bring in solder.
6. Heat for 3 seconds longer. Do not heat contact more than 4 seconds in total.
7. Remove soldering iron.
8. Wait until solder gets rigid again.
9. Do not solder adjacent contacts consecutively, alternate position within the connector to minimize heat build up.

RECOMMENDED PANEL CUT-OUT

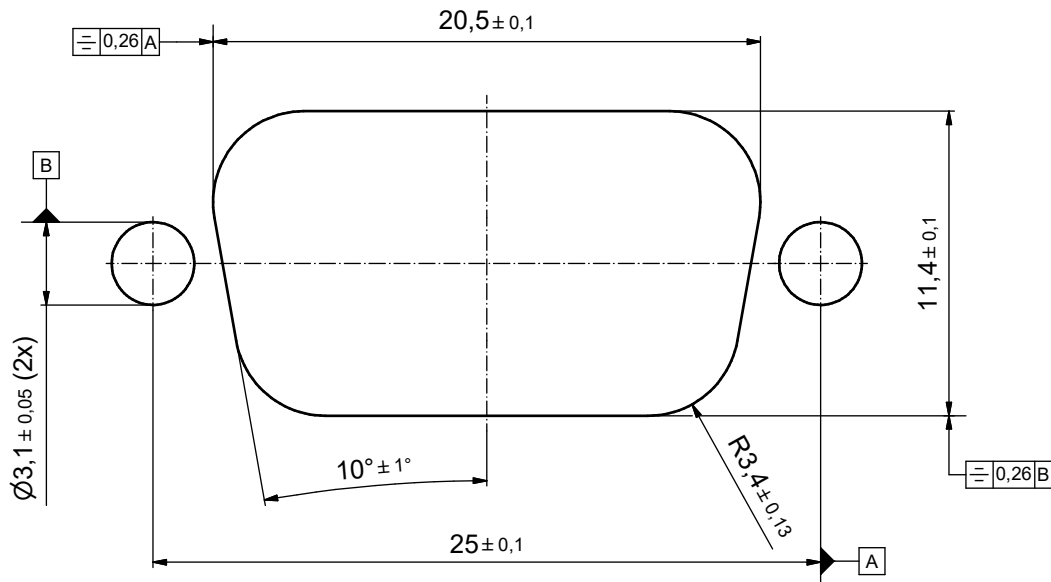

APPROVAL # FREIGABE # DEBLOCAGE # AUTORIZACION # APPROVAL	
CUSTOMER APPROVAL DATE:	
NAME:	TITLE:
COMPANY NAME:	
APPROVAL # FREIGABE # DEBLOCAGE # AUTORIZACION # APPROVAL	

THIS DRAWING MAY NOT BE COPIED OR REPRODUCED IN ANY WAY, AND MAY NOT BE PASSED ON TO A THIRD PARTY WITHOUT WRITTEN PERMISSION. OWNERSHIP AND COPYRIGHT OF CONEC GmbH				tolerance		dim. in mm	
DO NOT ALTER CAD DRAWING BY HAND				date		name	
a Origin				17.10.08		Petker	
rev. description				23.10.08		Fischer	
date				norm		d-old	
name				date		name	
				17.10.08		Petker	
				23.10.08		Fischer	
				norm			
				d-old			

scale: 5:1	
material: see sheet 1	
title: PANEL CUT-OUT D-SUB MALE HD 15pos. SOLDER CUP with hexlocking screw	
dwg no: Inventor 10	DIN-A3
15K1A280	
sh: 2	
part no: see sheet 1	



X-ON Electronics

Largest Supplier of Electrical and Electronic Components

Click to view similar products for [D-Sub High Density Connectors](#) category:

Click to view products by [CONEC](#) manufacturer:

Other Similar products are found below :

[97-3250-11](#) [163A17089X](#) [164A17199X](#) [164C18629X](#) [L717HDB44POL2R210](#) [L717HDEH15POL2](#) [L777HDE15P](#) [L77HDE15SC309](#)
[163A16759X](#) [163A16839X](#) [163A16989X](#) [163A17079X](#) [164A17329X](#) [164A18219X](#) [241A16440X](#) [241A16550X](#) [241A16680X](#)
[241A20810X](#) [241A25740X](#) [CT25-44P](#) [MDBE15PE766](#) [L177HDE15SOL2RM23](#) [L177HRC62SVFM](#) [L177HRCG62S](#)
[L717HDEG15POL2RM5](#) [L77HDA26SVF](#) [L77HDE15SD1CO](#) [L77HDEH15SOL2RM832](#) [DAMA-15S-WS](#) [443895-3](#) [106698-1](#) [280-](#)
[012K2C](#) [DBMV13H3SNA197](#) [L177HRB44S](#) [164A17039X](#) [09562004701510](#) [L777HRC62P](#) [241A17960X](#) [164A18269X](#) [280-019S1S9MEN](#)
[L777HDEG15P](#) [280-018P3S25MEGN](#) [206504-2](#) [40-9415HDSP](#) [40-9515HDSP](#) [2057140-1](#) [C115370-6002](#) [DFMA104SNMBFR172FR022](#)
[HDC9F200E2S](#) [L717HDAG26POL2RM8](#)