

(b) (d)

NOTES:

1. RECOMMENDED SOLDER INSTRUCTION SEE SHEET 2
2. IP RATING: IP 67
3. SEALED TO WITHSTAND PRESSURE UP TO 1,45 PSI FOR 30 MINUTES AFTER SOLDERING
4. METALSHELL: ZINC DIE CAST; min. 50µin NICKEL PLATING over COPPER
5. INSULATORS: PBT GF UL 94 V-0; BLACK
6. O-RING: SILICONE PER ASTM D2000 70 SHORE A
7. SEALING COMPOUND: EPOXY RESIN UL 94 V-0; BLACK
8. CONTACTS: COPPER ALLOY
PLATING (SEE PART NO.):
 PLEASE ADD 1 for 30µin HARD GOLD over min. 50µin NICKEL
 PLEASE ADD 3 for 8µin HARD GOLD over min. 50µin NICKEL
 SOLDER CUP ACCEPTS CABLE AWG 22
9. HEXLOCKING SCREWS: STAINLESS STEEL
10. RECOMMENDED PANEL CUT-OUT ON SHEET 2
11. RECOMMENDED TORQUE FOR MOUNTING SCREW
35Ncm (3.1 in.LB) / max. 67Ncm (6 in.LB)
12. OPERATING TEMPERATURE: -40°C to +105°C
13. CONNECTOR IS PART MARKED: 15-00070 CONEC ABC

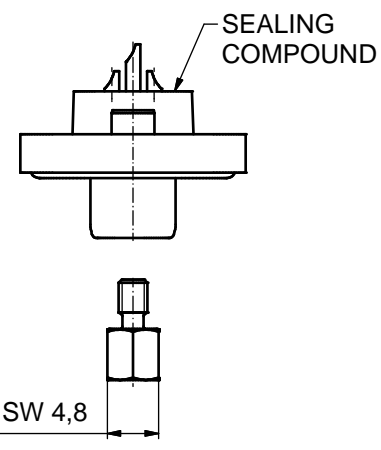
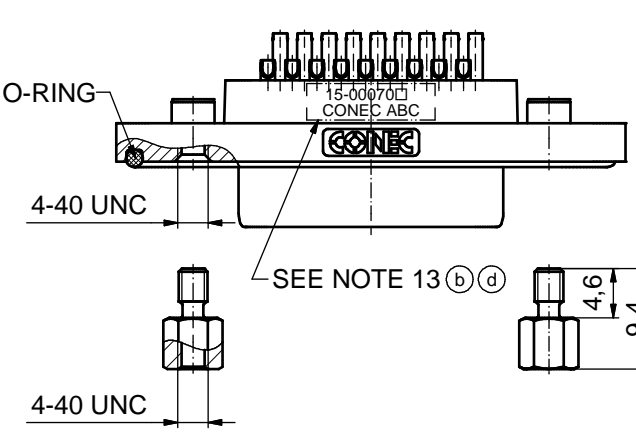
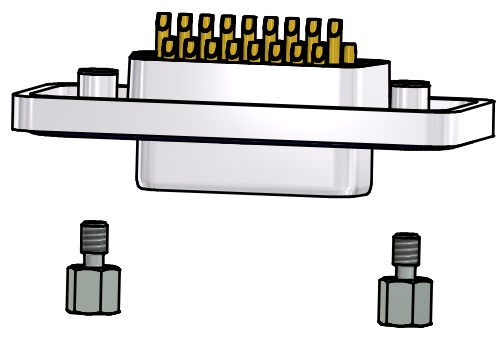
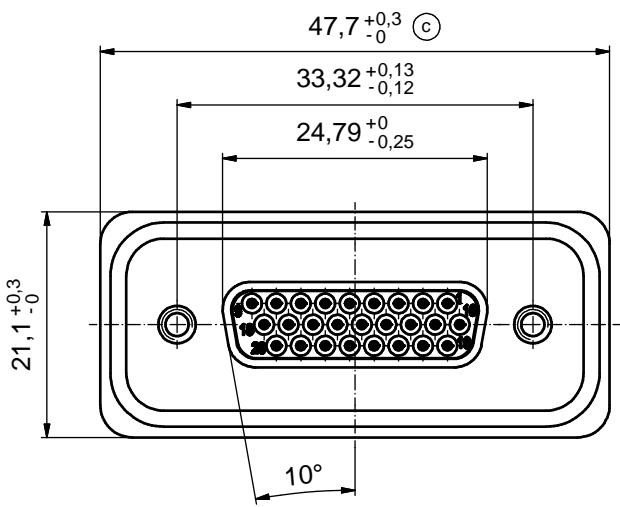
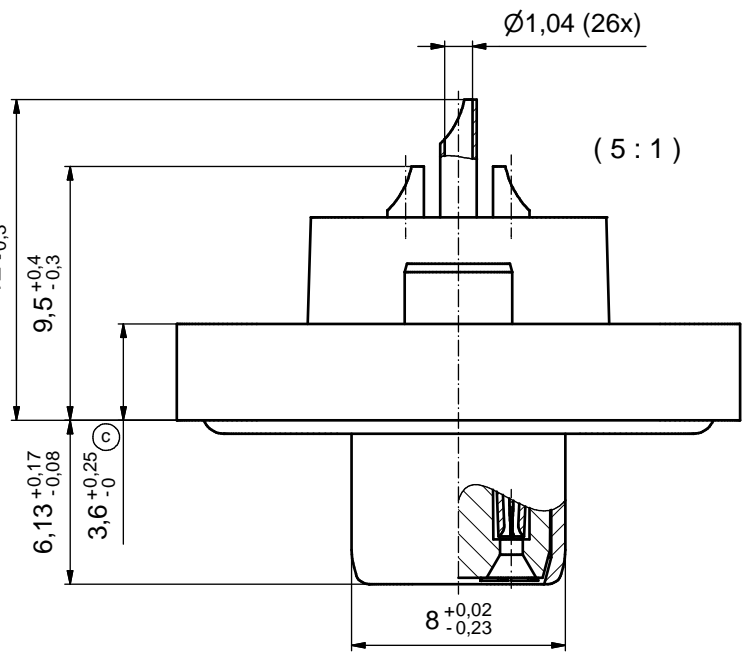

(c) AT ALL TIMES WATER RESISTANT CONNECTORS NOT IN USE SHOULD BE COVERED WITH A CONEC WATER RESISTANT CAP OR WATER TIGHT HOOD.

RoHS compliant

THIS DRAWING MAY NOT BE COPIED OR REPRODUCED IN ANY WAY, AND MAY NOT BE PASSED ON TO A THIRD PARTY WITHOUT WRITTEN PERMISSION. OWNERSHIP AND COPYRIGHT OF CONEC GmbH DO NOT ALTER CAD DRAWING BY HAND	tolerance		dim. in mm		scale:	2:1 (5:1)		
					material:	see notes		
					title:	D-SUB HD FEMALE		
					26pos. SOLDER CUP			DIN-A3
					with hexlocking screw			
2 x d	Ä 5445	03.12.14	Lehm.	norm	dwg no:	15K1A273		
3 x c	Ä 3435	01.10.09	HS	d-old				
3 x b	Ä 3129	26.09.08	Petker		part no:	15-00070 (see note 8) (b)		
a	Original							
rev.	description	date	name	CONEC				

ⓑ Solder Instruction

1. Cable should be prepared for soldering. The cable/wires must be pretinned.
2. Insert cable/wire into solder cup.
3. Operate the soldering iron at 350°C, 50 Watt max. and use a pencil tip.
4. Put tip to wire in solder cup.
5. After 1 second bring in solder.
6. Heat for 3 seconds longer. Do not heat contact more than 4 seconds in total.
7. Remove soldering iron.
8. Wait until solder gets rigid again.
9. Do not solder adjacent contacts consecutively, alternate position within the connector to minimize heat build up.

RECOMMENDED PANEL CUT-OUT ⓑ

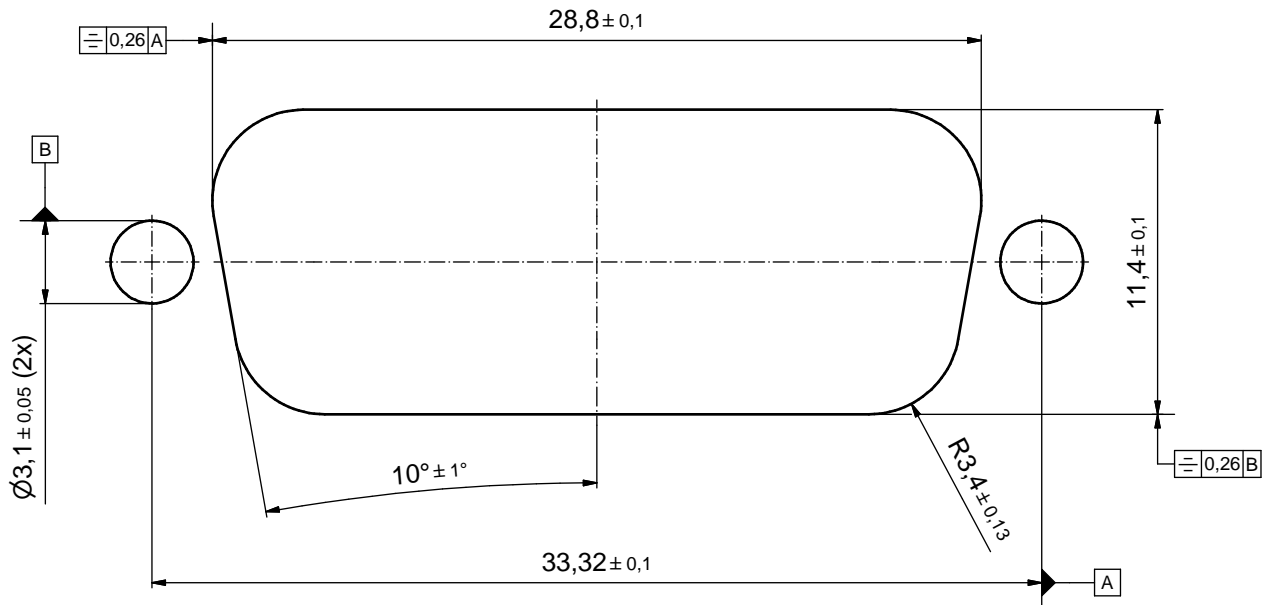

THIS DRAWING MAY NOT BE COPIED OR REPRODUCED IN ANY WAY, AND MAY NOT BE PASSED ON TO A THIRD PARTY WITHOUT WRITTEN PERMISSION. OWNERSHIP AND COPYRIGHT OF CONEC GmbH DO NOT ALTER CAD DRAWING BY HAND				tolerance		scale: 5:1
				date	name	material: SEE SHEET 1
				drawn	08.09.08	Schmidt
				appd.	15.09.08	Fischer
				norm		
			d-old			
2 x b	Ä 3129	26.09.08	Petker	CONEC [®] title: RECOMMENDED PANEL CUT-OUT D-SUB HD FEMALE 26pos. SOLDER CUP with hexlocking screw		
a	Original					
rev.	description	date	name	15K1A273		sh: 2
				part no: SEE SHEET 1		

X-ON Electronics

Largest Supplier of Electrical and Electronic Components

Click to view similar products for [D-Sub High Density Connectors](#) category:

Click to view products by [CONEC](#) manufacturer:

Other Similar products are found below :

[97-3250-11](#) [163A17089X](#) [164A17199X](#) [164C18629X](#) [L717HDB44POL2R210](#) [L717HDEH15POL2](#) [L777HDE15P](#) [L77HDE15SC309](#)
[163A16759X](#) [163A16839X](#) [163A16989X](#) [163A17079X](#) [164A17329X](#) [164A18219X](#) [241A16440X](#) [241A16550X](#) [241A16680X](#)
[241A20810X](#) [241A25740X](#) [CT25-44P](#) [MDBE15PE766](#) [L177HDE15SOL2RM23](#) [L177HRC62SVFM](#) [L177HRCG62S](#)
[L717HDEG15POL2RM5](#) [L77HDA26SVF](#) [L77HDE15SD1CO](#) [L77HDEH15SOL2RM832](#) [DAMA-15S-WS](#) [443895-3](#) [106698-1](#) [280-](#)
[012K2C](#) [DBMV13H3SNA197](#) [L177HRB44S](#) [164A17039X](#) [09562004701510](#) [L777HRC62P](#) [241A17960X](#) [164A18269X](#) [280-019S1S9MEN](#)
[L777HDEG15P](#) [280-018P3S25MEGN](#) [206504-2](#) [40-9415HDSP](#) [40-9515HDSP](#) [2057140-1](#) [C115370-6002](#) [DFMA104SNMBFR172FR022](#)
[HDC9F200E2S](#) [L717HDAG26POL2RM8](#)