

used for: D-SUB FILTER

POS.	A -0.76	B -0.25	C	PART-NO.
9	31.19	16.46	25.00 $+0.12$ -0.13	242A17660X
15	39.52	24.79	33.30 $+0.15$ -0.1	242A17670X
25	53.42	38.50	47.04 ± 0.13	242A17680X
37	69.70	54.96	63.50 ± 0.13	242A17690X

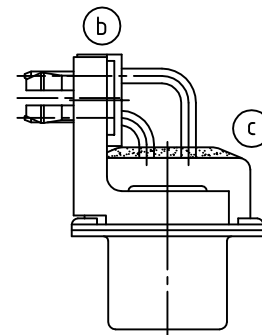
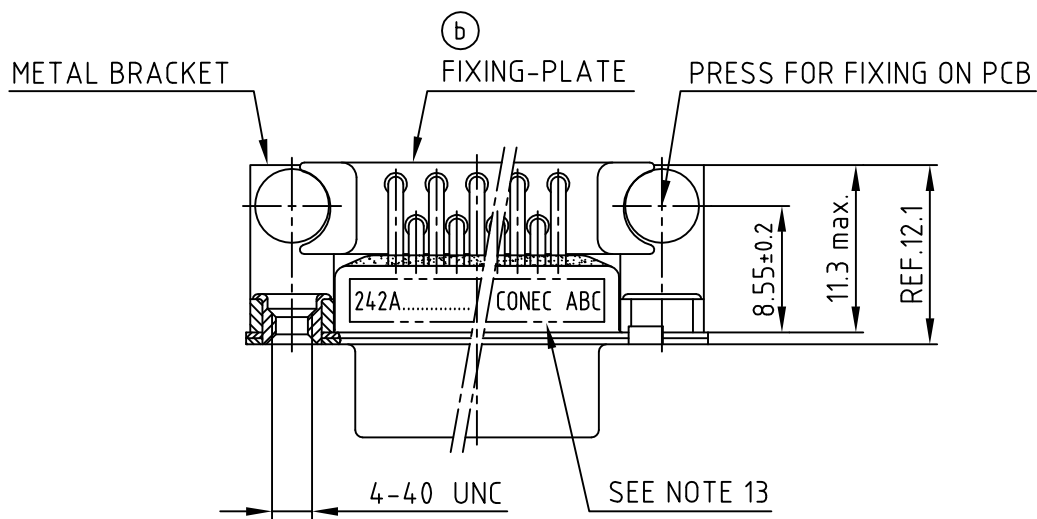
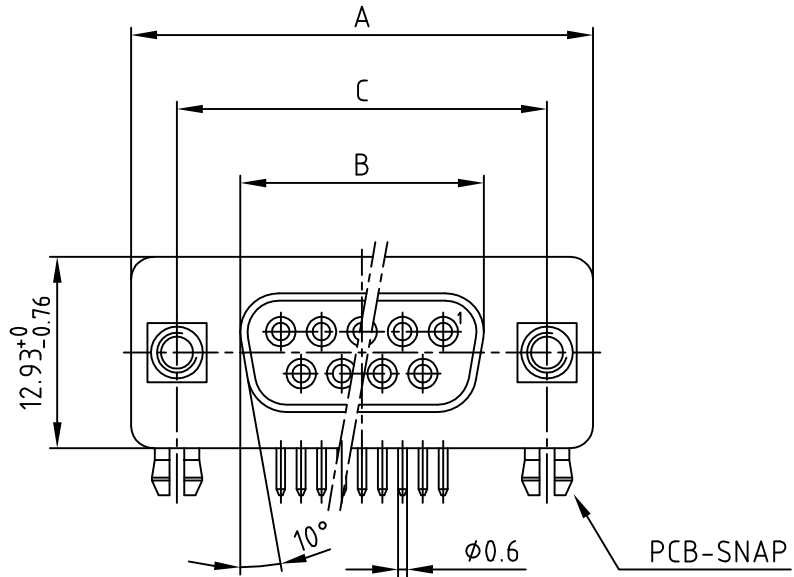
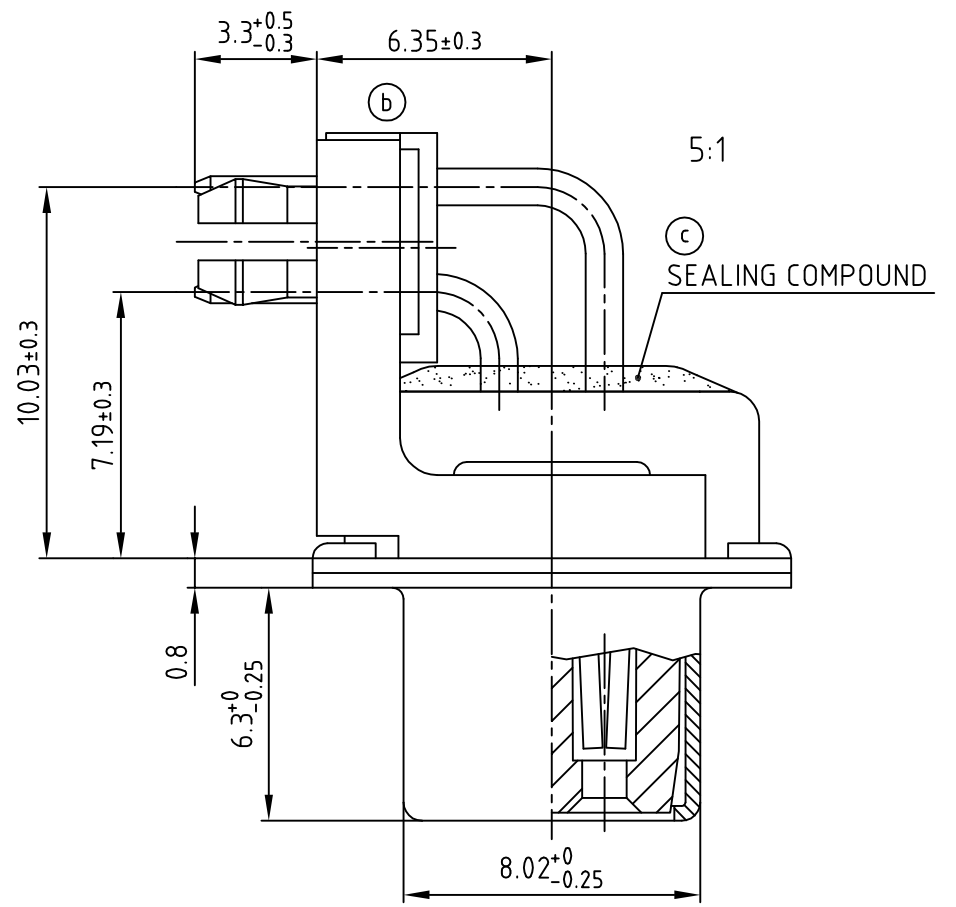

(b) NOTES:

1. RoHS COMPLIANT
2. SUITABLE FOR WAVESOLDERING
3. METAL SHELLS: STEEL; min. 315µm TIN over 40-80µm NICKEL
4. INSULATORS: HIGH TEMPERATURE PLASTIC UL 94 V-0, BLACK
5. CONTACTS: COPPER ALLOY
PLATING: 8µm HARD GOLD OVER min. 50µm NICKEL
6. METAL BRACKET: ZINC DIE CAST; 300µm COPPER/40-120µm NICKEL/120-200µm TIN
7. THREADED INSERT: COPPER ALLOY; min. 200µm TIN over 80µm NICKEL
8. FIXING-PLATE: PBT GF UL 94 V-0, BLACK
9. P.C.B. HOLE DRILLINGS ON SHEET 2
10. CAPACITANCE: 1300pF $\pm 20\%$
11. DIELECTRIC WITHSTANDING VOLTAGE: 424 VDC
12. MAXIMUM TORQUE VALUE FOR THREAD: 6 in.LB
13. CONNECTOR IS PART MARKED: PART-NO. CONEC ABC

Directive 2002/95/EC RoHS compliant

APPROVAL # FREIGABE # DEBLOCAGE # AUTOR/ZACION # APPROVAL	
CUSTOMER APPROVAL DATE:	
NAME:	TITLE:
COMPANY NAME:	
APPROVAL # FREIGABE # DEBLOCAGE # AUTOR/ZACION # APPROVAL	

THIS DRAWING MAY NOT BE COPIED OR REPRODUCED IN ANY WAY, AND MAY NOT BE PASSED ON TO A THIRD PARTY WITHOUT WRITTEN PERMISSION.
OWNERSHIP AND COPYRIGHT OF CONEC GmbH
DO NOT ALTER CAD DRAWING BY HAND

2 x c	Ä 4000	12.05.2011	Lehmen,	d-old
4 x b	Ä 3123	23.09.2008	Lehmen,	
a	Original			
rev.	description	date	name	

tolerance		dim. in mm	scale:	2:1 (5:1)
			material:	SEE NOTES
1997	date	name	title: D-SUB FILTER FEMALE 90° 9-37pos. 0.318inch with threaded insert, metal bracket and snap	
drawn	04.11.	Barcinski		
appd.	04.11.	Mickenbecker		
norm		DIN 41652		
dwg no:		AutoCAD 2006	DIN-A	
		24K11W0A	3	
part no:		SEE TABLE		



dwg no:	AutoCAD 2006	DIN-A
	24K11W0A	3
part no:	SEE TABLE	

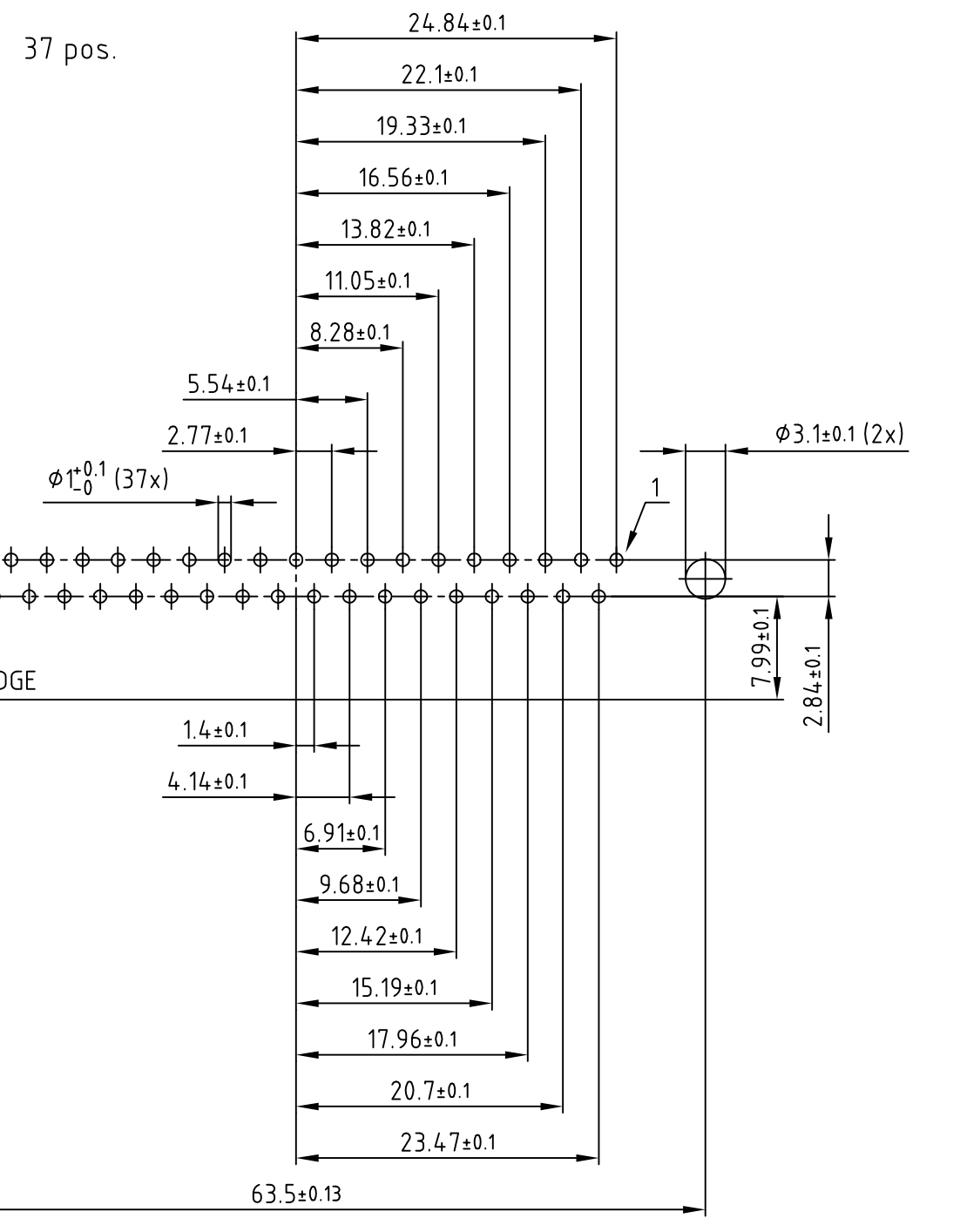
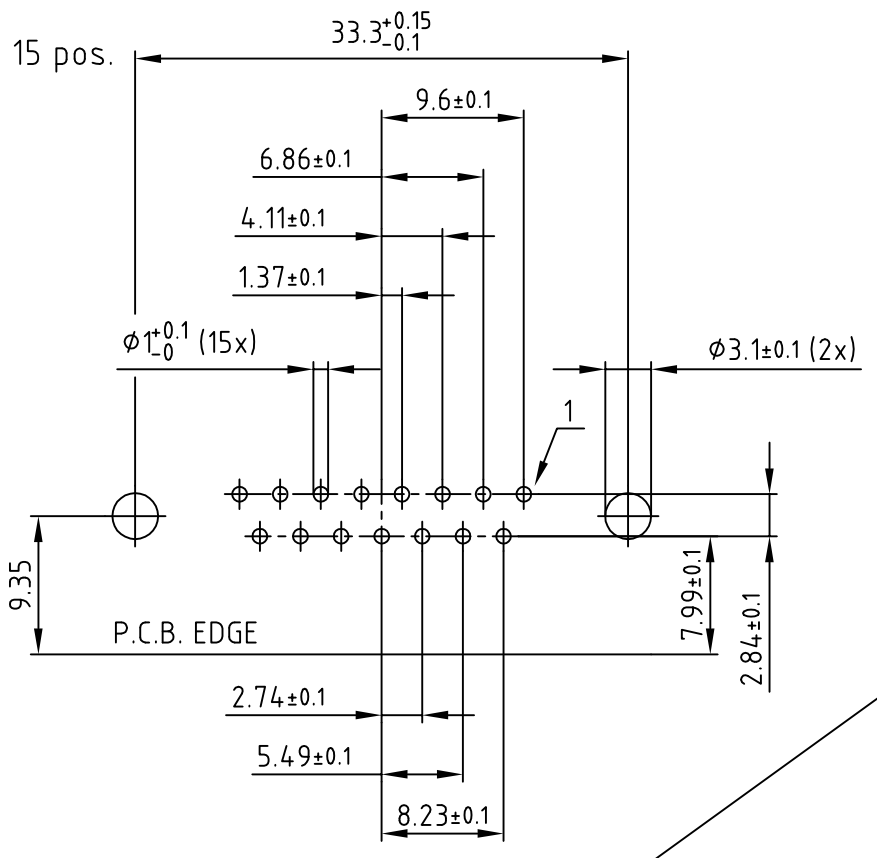
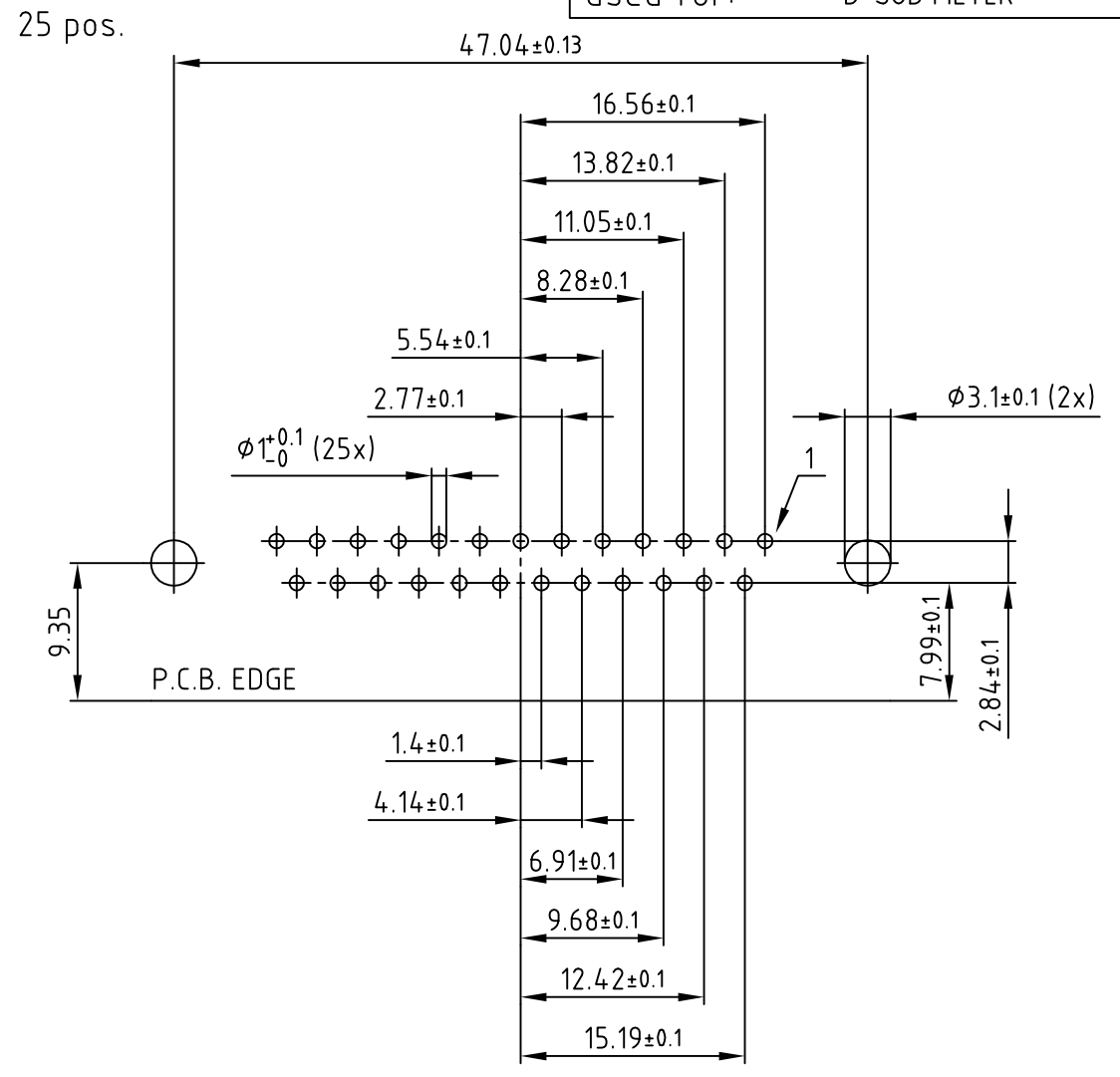
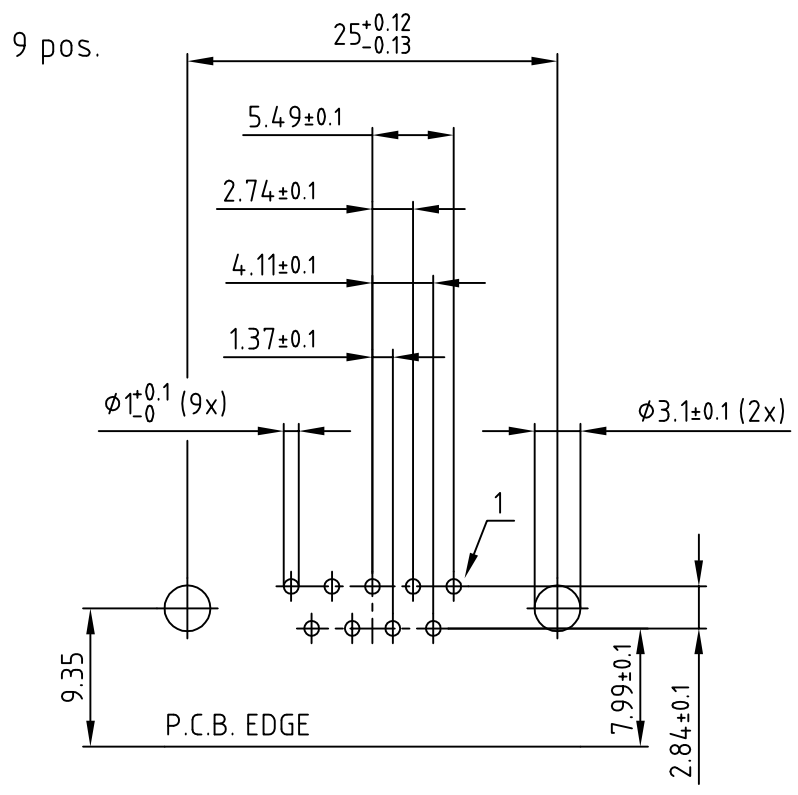

APPROVAL # FREIGABE # DEBLOCAGE # AUTOR/ZACION # APPROVAL

CUSTOMER APPROVAL DATE:

NAME: TITLE:

COMPANY NAME:

APPROVAL # FREIGABE # DEBLOCAGE # AUTOR/ZACION # APPROVAL

THIS DRAWING MAY NOT BE COPIED OR REPRODUCED IN ANY WAY, AND MAY NOT BE PASSED ON TO A THIRD PARTY WITHOUT WRITTEN PERMISSION.

OWNERSHIP AND COPYRIGHT OF CONEC GmbH

DO NOT ALTER CAD DRAWING BY HAND

tolerance		dim. in mm	scale: 2:1	
			material: SEE SHEET 1	
2008	date	title:		
drawn	23.09.	P.C.B. HOLE DRILLINGS		
appd.	23.09.	D-SUB FILTER FEMALE 90° 9-37pos. 0.318inch with threaded insert, metal bracket and snap		
norm	DIN 41652			
d-old				
a	Original			
rev.	description			
date	name	dwg no: AutoCAD 2006		DIN-A
		24K11W0A		3
		part no: SEE SHEET 1		sh:2/2

dwg no: AutoCAD 2006		DIN-A
24K11W0A		3
part no: SEE SHEET 1		sh:2/2

X-ON Electronics

Largest Supplier of Electrical and Electronic Components

Click to view similar products for [D-Sub Standard Connectors](#) category:

Click to view products by [CONEC](#) manufacturer:

Other Similar products are found below :

[56F711-015](#) [012-9507-004](#) [LV242999-142T12](#) [015-0341-000](#) [015-0349-000](#) [015-0372-005](#) [015-0372-008](#) [015-8755-001](#) [020419-0104](#) [012-0467-000](#) [012-0515-000](#) [012-9507-034](#) [012-9507-114](#) [020745-0008](#) [609-25P](#) [M24308/2-23Z](#) [M24308315F](#) [CT2-14S-2PCA34](#) [CT2-18-11PCAU](#) [CT2-36-15SC](#) [CT6-14S-2SC](#) [CT6E14SA7SC](#) [CT6E22-14PC](#) [CT6E22-14PS](#) [CT6E22-22PS](#) [M83513/01-FC](#) [M85049/48-3-2F](#) [6STD09PCM99B70X](#) [6STD09SCM99B30X](#) [6STD09SCT99S40X](#) [6STD15PCT99S40X](#) [6STD15SCM99B30X](#) [6STD15SCT99S40X](#) [6STF09PCM05B70X](#) [7-135760-9](#) [MC11E-10-6SN](#) [747552-3](#) [MD1-21PS](#) [MDM-15SCBRM7-F222](#) [MDM96517-699](#) [MDM96521-744](#) [MDVB1-21SL1](#) [MIK0-1-7SH003](#) [MIKQ6-7SH076](#) [MIKQ7-7PH077](#) [MIKQ7-7PH11](#) [MIKQ7-7PH32](#) [MIKQ9-7PH003](#) [MJSV-28SL61](#) [MKJ4A1F14-55S](#)