

BOM LIST			
ITEM	PART NAME	Q'ty	NOTES
1	PLASTIC HOOD	2	SEE P/N
2	2.1 LONG BOLT	2	#4-40
	2.2 SHORT BOLT	2	#4-40
3	NUT	2	M3
4	LONG SCREW	2	M3
5	SMALL WASHER	2	
6	SHORT SCREW	2	M3
7	METAL WASHER	2	M3

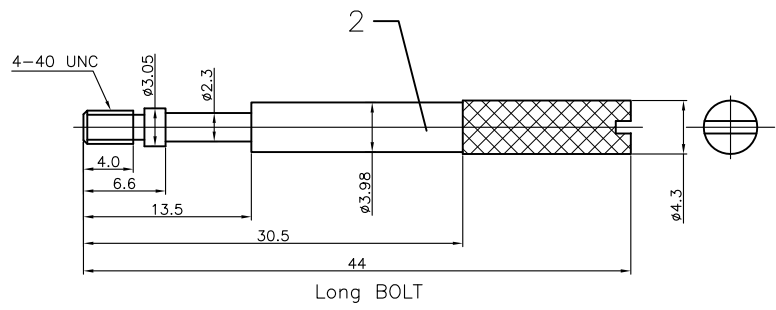

REV.	DESCRIPTION	DRAWN	CHECKED	APPROVED
A	NEW RELEASE	LJH 05/18/05'	~	LJC 05/18/05'
C	整理英制短螺丝尺寸	YCH 07/18/08'	~	LJC 07/18/08'
D	增加“全包装”类型	YCH 05/20/10'	~	LJC 05/20/10'
E	ADD P/N CODE	LJC 12/24/13'	~	LJC 12/24/13'
H	Short BOLT CHANGE	JLZ 03/13/15'	~	

NOTES:
 1. Hardwares are all Nickel plated.
 2. PART NUMBER CODE:
 DS1045 - 15 X X X X X - X

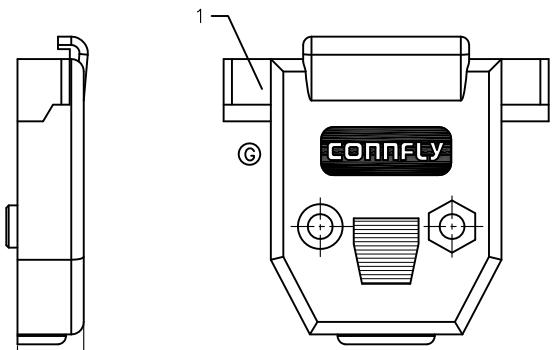
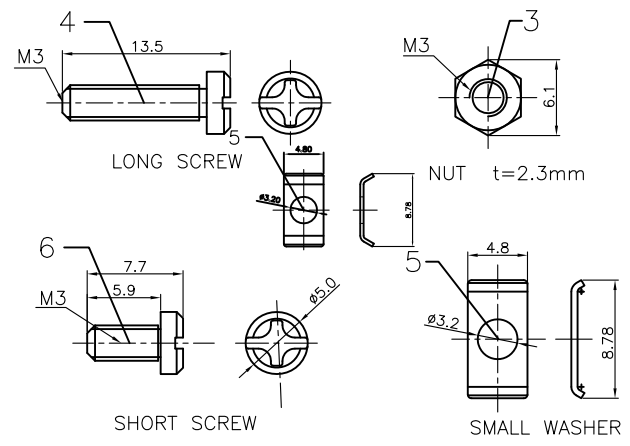
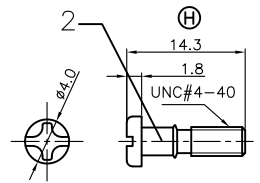
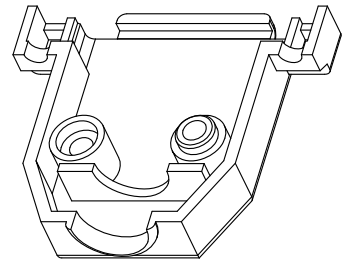

Hood Materials (E)
 A: ABS
 B: Similar ABS

Washer type
 1: Metal

Bolt type
 L: Long
 S: Short

Packing type
 1: Mix packing
 Q: Full packing

Cover Material
 P: Plastic(ABS)
 Cover Color
 A: Gray
 B: Black
 V: Ivory
 Position
 15: 15pin

GENERAL TOLERANCE		ANGLE TOLERANCE	
X.	±0.60	X.	±5°
.X	±0.38	.X	±3°
.XX	±0.25	.XX	±2°

PROJECTION	TITLE	D-SUB Plastic Hood 180° 15 Positions	
UNITS	mm		
SHEET SIZE	A4	SERIES	DS1045 SERIES

DRAWING TYPE	CUSTOMER		
SCALE	1:1	SHEET	1 OF 1
DRAWING NO.	C-DS1045-15XXXXX-X-H		

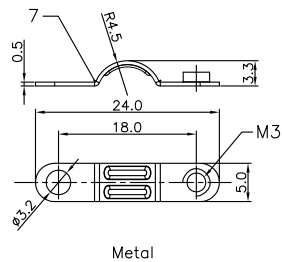
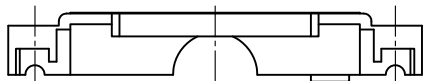
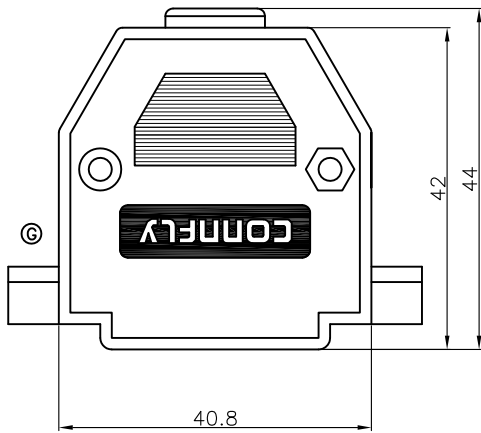
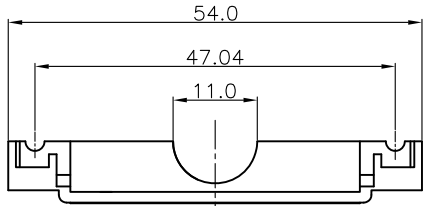

晨翔电子有限公司
CONNFly® CONNFly ELECTRONIC CO., LTD

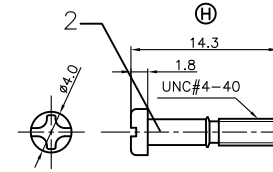
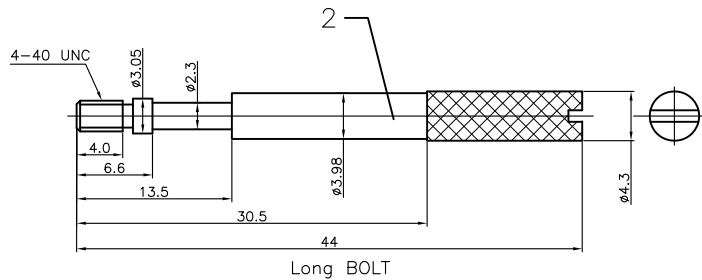
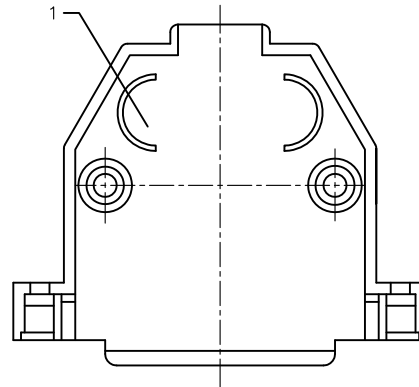
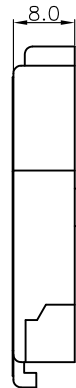

BOM LIST			
ITEM	PART NAME	Q'ty	NOTES
1	PLASTIC HOOD	2	SEE P/N
2	2.1 LONG BOLT	2	#4-40
	2.2 SHORT BOLT	2	#4-40
3	NUT	2	M3
4	LONG SCREW	2	M3
5	SMALL WASHER	2	
6	SHORT SCREW	2	M3
7	METAL WASHER	2	M3

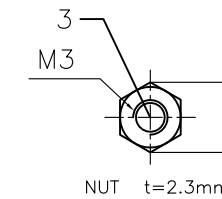

Short BOLT



NUT t=2.3mm

NOTES:

1. Hardwares are all Nickel plated.

2. PART NUMBER CODE:

DS1045 - 25 X X X X X - X

Hood Materials (E)

A: ABS
B: Similar ABS

Washer type

1: Metal

Bolt type

L: Long

S: Short

Packing type

1: Mix packing

Q: Full packing

Cover Material

P: Plastic(ABS)

Cover Color

A: Gray

B: Black

V: Ivory

Position

25: 25pin

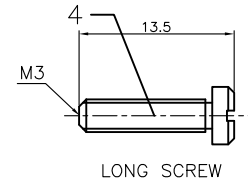

LONG SCREW

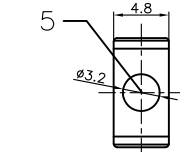

SMALL WASHER

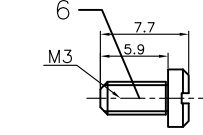

SHORT SCREW

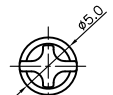
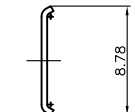

GENERAL TOLERANCE		ANGLE TOLERANCE	
X.	±0.60	X.	±5°
.X	±0.38	.X	±3°
.XX	±0.25	.XX	±2°

PROJECTION	TITLE	D-SUB Plastic Hood 180° 25 Positions	
UNITS	mm		
SHEET SIZE	A4	SERIES	DS1045 SERIES

DRAWING TYPE	COSTOMER		
SCALE	1:1	SHEET	1 OF 1
DRAWING NO.	C-DS1045-25XXXXX-X-H		

 晨翔电子有限公司
CONNFLY ELECTRONIC CO., LTD

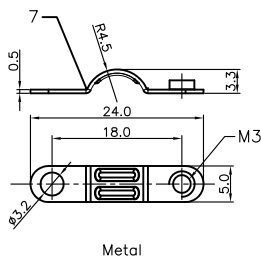
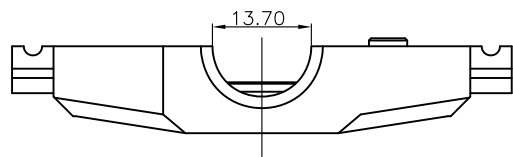
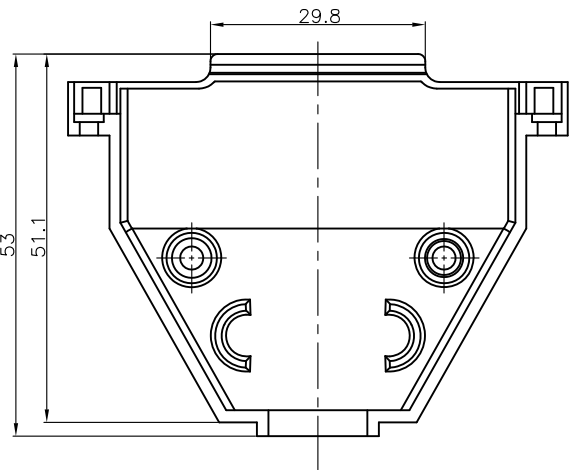
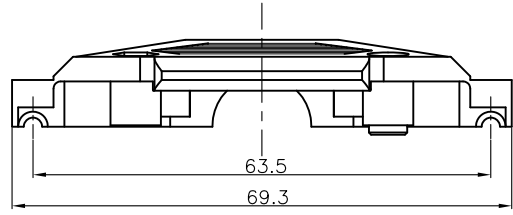

BOM LIST			
ITEM	PART NAME	Q'ty	NOTES
1	PLASTIC HOOD	2	SEE P/N
2	LONG BOLT	2	#4-40
	SHORT BOLT	2	#4-40
3	NUT	2	M3
4	LONG SCREW	2	M3
5	SMALL WASHER	2	
6	SHORT SCREW	2	M3
7	METAL WASHER	2	M3

REV.	DESCRIPTION	DRAWN	CHECKED	APPROVED
A	NEW RELEASE	LJH 10/26/05'	~	LJC 10/26/05'
C	整理英制短螺丝尺寸	YCH 07/18/08'	~	LJC 07/18/08'
D	增加“全包装”类型	YCH 05/20/10'	~	LJC 05/20/10'
E	ADD P/N CODE	LJC 12/24/13'	~	LJC 12/24/13'
H	Short BOLT CHANGE	JLZ 03/13/15'	~	

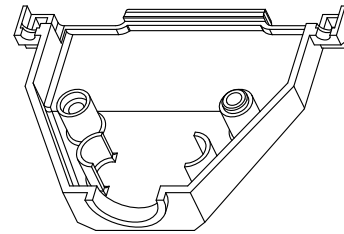

NOTES:
 1. Hardwares are all Nickel plated.
 2. PART NUMBER CODE:
 DS1045 - 37 X X X X X X - X

Hood Materials (C)
 A: ABS
 B: Similar ABS

Washer type
 1: Metal

Bolt type
 L: Long
 S: Short

Packing type
 1: Mix packing
 Q: Full packing

Cover Material
 P: Plastic(ABS)

Cover Color
 A: Gray
 B: Black
 V: Ivory

Position
 37: 37pin

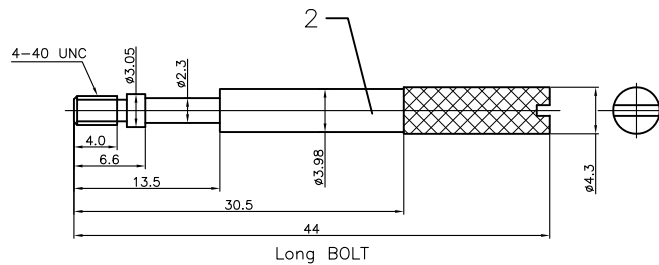
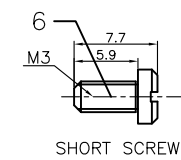
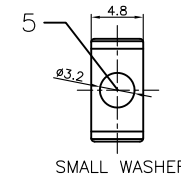
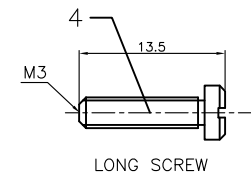
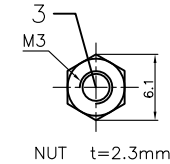
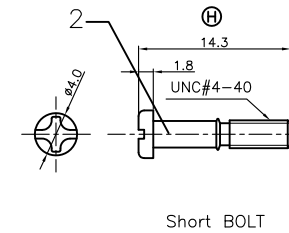
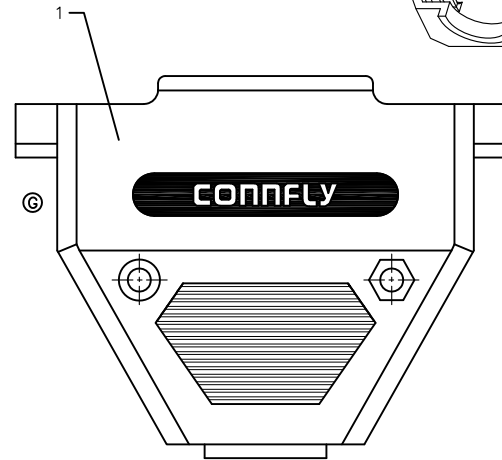
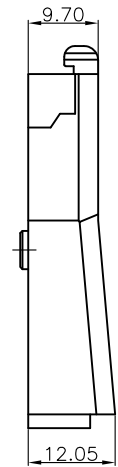

GENERAL TOLERANCE	ANGLE TOLERANCE
X. ±0.60	X. ±5°
.X ±0.38	.X ±3°
.XX ±0.25	.XX ±2°

PROJECTION	TITLE	D-SUB Plastic Hood 180° 37 Positions	
UNITS	mm		
SHEET SIZE	A4	SERIES	DS1045 SERIES

DRAWING TYPE	COSTOMER		
SCALE	1:1	SHEET	1 OF 1
DRAWING NO.	C-DS1045-37XXXXX-X-H		

 晨翔电子有限公司
CONNFly® CONNFly ELECTRONIC CO., LTD

REV.	DESCRIPTION	DRAWN	CHECKED	APPROVED
A	NEW RELEASE	YCH 05/24/11'	~	LJC 05/24/11'
B	ADD P/N CODE	LJC 12/24/13'	~	LJC 12/24/13'
C	Arrange Drawing	JLZ 10/09/14'	~	LJC 10/09/14'
D	ADD LOGO	JLZ 12/17/14'	~	

NOTES:
 1. Hardware are all Nickel plated.
 2. PART NUMBER CODE:
 DS1045 - 50 X X X - X

- Hood Materials®
 - A: ABS
 - B: Similar ABS
- Packing type
 - 1: Mix packing
- Cover Color
 - A: Gray
 - B: Black
- Cover Material
 - P: Plastic(ABS)
- Position
 - 50: 50pin

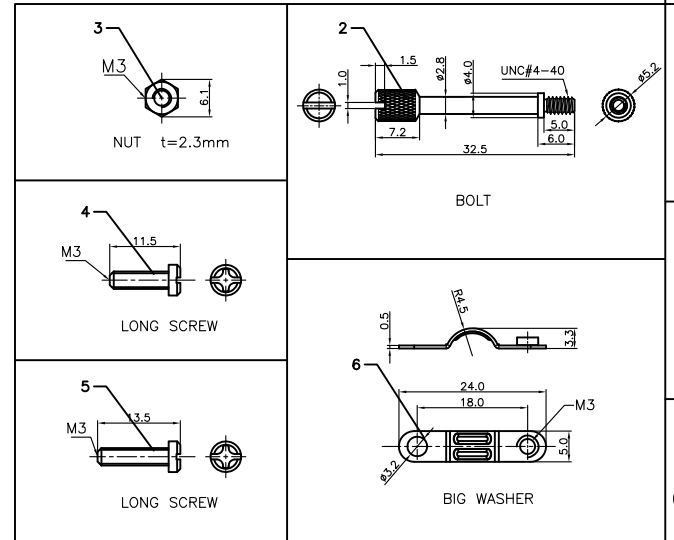
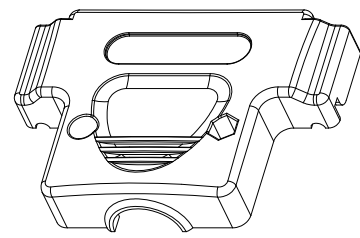
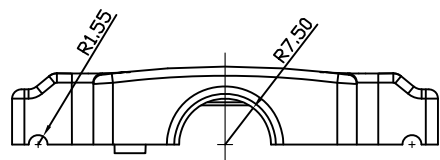
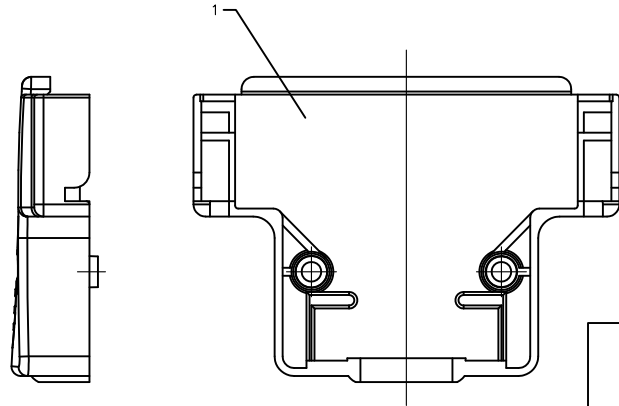
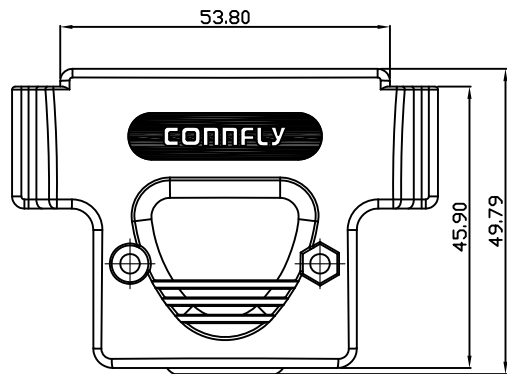
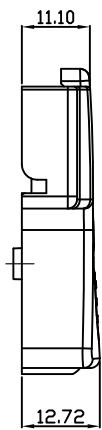
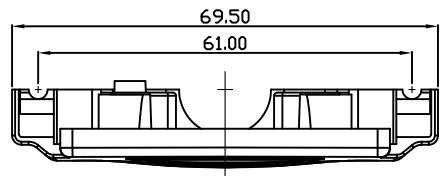

BOM LIST			
ITEM	PART NAME	Q'ty	NOTES
1	PLASTIC HOOD	2	SEE P/N
2	BOLT	2	#4-40
3	NUT	2	M3
4	M3*10 SCREW	2	M3
5	M3*12 SCREW	2	M3
6	BIG WASHER	2	M3

GENERAL TOLERANCE		ANGLE TOLERANCE	
X.	±0.60	X.	±5°
.X	±0.38	.X	±3°
.XX	±0.25	.XX	±2°

PROJECTION		TITLE	D-SUB Plastic Hood 180° 50 Positions
UNITS	mm	SHEET	1 OF 1
SHEET SIZE	A4	SERIES	DS1045 SERIES

DRAWING TYPE	CUSTOMER
SCALE	1:1
DRAWING NO.	C-DS1045-50XXX-X-D

晨翔电子有限公司
CONNFLY® CONNFLY ELECTRONIC CO., LTD

X-ON Electronics

Largest Supplier of Electrical and Electronic Components

Click to view similar products for [D-Sub Standard Connectors](#) category:

Click to view products by [Connfly](#) manufacturer:

Other Similar products are found below :

[56F711-015](#) [LV242999-142T12](#) [015-0339-000](#) [015-0341-000](#) [015-0349-000](#) [015-0350-000](#) [015-0372-008](#) [015-8544-011](#) [015-8755-001](#)
[017041-0005](#) [020419-0104](#) [012-0467-000](#) [012-9507-114](#) [020745-0008](#) [609-25P](#) [609-9P](#) [M24308/2-23Z](#) [M24308/2-36Z](#) [M24308315F](#)
[CT0M22-23SS](#) [CT0P14S-5SXS](#) [CT0P22-14PS](#) [CT1E20-19SS](#) [CT2-10SL-3SC](#) [CT2-14S-2PCA34](#) [CT2-16S-17PS](#) [CT2-18-10PS-FMLB-D](#)
[CT2-18-11PCAU](#) [CT2-18-1PSAUA34](#) [CT2-22-19SC](#) [CT2-22-19SS-A206](#) [CT2-24-2PS](#) [CT2-28-12SC](#) [CT2-28-12SSA232](#) [CT6-10SL-3SC](#)
[CT6-10SL-4SC](#) [CT6-14S-2SC](#) [CT6-16-12SC](#) [CT6-18-10PSA206](#) [CT6-18-10PSA232](#) [CT6-18-10SSF127A206](#) [CT6-22-10PS](#) [CT6-28-22SS](#)
[CT6E14S-2S0](#) [CT6E14S-2SC-A206](#) [CT6E14S-5SC](#) [CT6E14SA7SC](#) [CT6E20-14SS](#) [CT6E22-10PS](#) [CT6E22-14PC](#)