

FEATURES

- Dropout Voltage is 1.2V(Typ)
- Reference/Output Voltage Trimmed to $\pm 2\%$
- Maximum Input Voltage is 15V
- Adjustable Output Voltage or Fixed 1.2V, 1.25V, 1.5V, 1.8V, 2.5V, 2.85V, 3.3V, 5V
- Line Regulation typically at 0.2% max
- Load Regulation typically at 0.4% max
- Current Limiting and Thermal Protection
- Standard 3-Pin Power Packages
- Operating Junction Temperature Range -40 to +125°C (for CBM1117C-1.2V is 0 to +150°C)

APPLICATIONS

- Post Regulator for switching DC/DC Converter
- High Efficiency Linear Regulator
- Battery Chargers
- PC Add on Card
- Motherboard clock supplies
- LCD Monitor
- Set-top Box

GENERAL DESCRIPTION

The CBM1117C is a series of low dropout voltage regulators which can provide up to 1A of output current. The CBM1117C is available in eight fixed voltage, 1.2, 1.25, 1.5, 1.8, 2.5, 2.85, 3.3 and 5.0V. Additionally it is also available in adjustable version. On chip precision trimming adjusts the reference/ output voltage to within $\pm 2\%$. Current limit is also trimmed to ensure specified output current and controlled short-circuit current.

The CBM1117C series is available in SOT-223, TO-252, TO-263 packages.

A minimum of 10uF tantalum capacitor is required at the output to improve the transient response and Stability.

PIN CONFIGURATION

4-Pin SOT-223
Top View

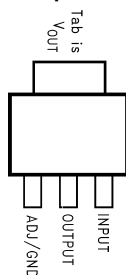

3-Pin TO-263
Top View

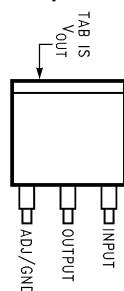

3-Pin TO-252
Top View

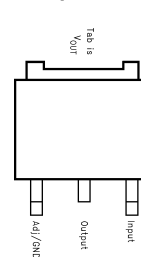

TYPICAL APPLICATION

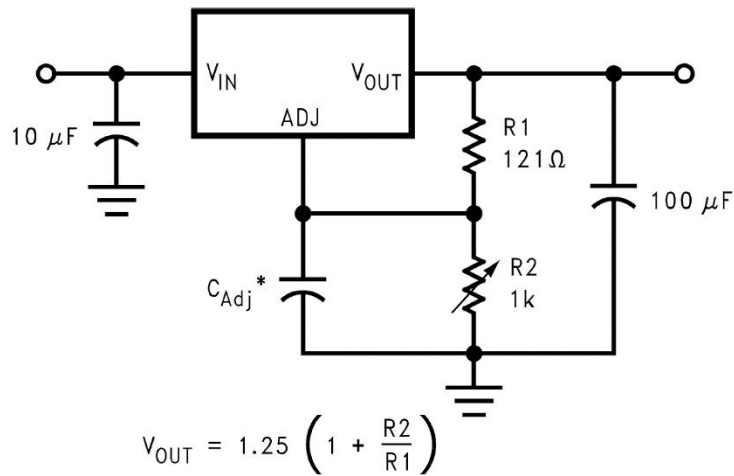

* C_{Adj} is optional, however it will improve ripple rejection.

Maximum ratings

SYMBOL	DESCRIPTION	MAX	UNITS
V _{IN}	Input Voltage	15	V
I _{OUT}	DC Output Current	PD/(V _{IN} -V _O)	mA
T _J	Operating Junction Temperature Range (* in case of CBM1117C-(1.2))	-40 to 125 (* 0 to 150)	°C
Θ _{JA}	Thermal Resistance Junction-to-Ambient (SOT-223)	150	°C/W
Θ _{JA}	Thermal Resistance Junction-to-Ambient (TO-252)	80	°C/W
Θ _{JA}	Thermal Resistance Junction-to-Ambient (TO-220)	60	°C/W
Θ _{JC}	Thermal Resistance Junction-to-Case (SOT-223)	35	°C/W
Θ _{JC}	Thermal Resistance Junction-to-Case (TO-252)	22	°C/W
Θ _{JC}	Thermal Resistance Junction-to-Case (TO-220)	15	°C/W

* Stresses beyond those listed under “absolute maximum ratings” may cause permanent damage to the device. These are stress ratings only and functional operation of the device at these or any other conditions beyond those indicated under “recommended operating conditions” is not implied.

Exposure to absolute-maximum-rated conditions for extended periods may affect device reliability.

ELECTRICAL CHARACTERISTICS

$T_j = -40^{\circ}\text{C}$ to $+125^{\circ}\text{C}$ (for CBM1117C-1.2 $T_j = 0$ to $+150^{\circ}\text{C}$) unless otherwise specified

PARAMETER	CONDITIONS	MIN	TYP	MAX	UNIT
OUTPUT VOLTAGE					
CBM1117C-1.2	$I_o = 10\text{mA}$ to 1.0A , $V_{in} = 2.7$ to 12.0V	1.176	1.200	1.224	V
CBM1117C-1.25 (Adjustable)	$I_o = 10\text{mA}$ to 1.0A , $V_{in} = 2.8$ to 12.0V	1.225	1.250	1.280	
CBM1117C-1.5	$I_o = 10\text{mA}$ to 1.0A , $V_{in} = 3.0$ to 12.0V	1.470	1.500	1.530	
CBM1117C-1.8	$I_o = 10\text{mA}$ to 1.0A , $V_{in} = 3.3$ to 12.0V	1.764	1.800	1.836	
CBM1117C-2.5	$I_o = 10\text{mA}$ to 1.0A , $V_{in} = 4.0$ to 12.0V	2.450	2.500	2.550	
CBM1117C-2.85	$I_o = 10\text{mA}$ to 1.0A , $V_{in} = 4.4$ to 12.0V	2.790	2.850	2.910	
CBM1117C-3.3	$I_o = 10\text{mA}$ to 1.0A , $V_{in} = 4.8$ to 12.0V	3.240	3.300	3.360	
CBM1117C-5.0	$I_o = 10\text{mA}$ to 1.0A , $V_{in} = 6.5$ to 12.0V	4.900	5.000	5.100	
LINE REGULATION					
CBM1117C-1.2	$I_o = 10\text{mA}$, $V_{in} = 2.7$ to 12.0V		2.0	7.0	mV
CBM1117C-1.25 (Adjustable)	$I_o = 10\text{mA}$, $V_{in} = 2.8$ to 12.0V		0.1	0.2	%
CBM1117C-1.5	$I_o = 10\text{mA}$, $V_{in} = 3.0$ to 12.0V		2.0	7.0	mV
CBM1117C-1.8	$I_o = 10\text{mA}$, $V_{in} = 3.3$ to 12.0V		2.0	7.0	mV
CBM1117C-2.5	$I_o = 10\text{mA}$, $V_{in} = 4.0$ to 12.0V		2.0	7.0	mV
CBM1117C-2.85	$I_o = 10\text{mA}$, $V_{in} = 4.4$ to 12.0V		2.0	7.0	mV
CBM1117C-3.3	$I_o = 10\text{mA}$, $V_{in} = 4.8$ to 12.0V		3.0	7.0	mV
CBM1117C-5.0	$I_o = 10\text{mA}$, $V_{in} = 6.5$ to 12.0V		4.0	10.0	mV
LOAD REGULATION					
CBM1117C-1.2	$I_o = 10\text{mA}$ to 1.0A , $V_{in} = 3.2\text{V}$		3.0	10.0	mV
CBM1117C-1.25 (Adjustable)	$I_o = 10\text{mA}$ to 1.0A , $V_{in} = 3.3\text{V}$		0.2	0.4	%
CBM1117C-1.5	$I_o = 10\text{mA}$ to 1.0A , $V_{in} = 3.5\text{V}$		3.0	10.0	mV
CBM1117C-1.8	$I_o = 10\text{mA}$ to 1.0A , $V_{in} = 3.8\text{V}$		3.0	10.0	mV
CBM1117C-2.5	$I_o = 10\text{mA}$ to 1.0A , $V_{in} = 4.5\text{V}$		3.0	10.0	mV
CBM1117C-2.85	$I_o = 10\text{mA}$ to 1.0A , $V_{in} = 4.85\text{V}$		3.0	10.0	mV
CBM1117C-3.3	$I_o = 10\text{mA}$ to 1.0A , $V_{in} = 5.3\text{V}$		4.0	12.0	mV
CBM1117C-5.0	$I_o = 10\text{mA}$ to 1.0A , $V_{in} = 7.0\text{V}$		5.0	15.0	mV
DROPOUT VOLTAGE (2)					
All Models	$I_o = 1\text{A}$ ($T_j = 25^{\circ}\text{C}$)		1.20	1.30	V
	$I_o = 1\text{A}$ ($T_j = -40^{\circ}\text{C}$ to $+125^{\circ}\text{C}$)		1.20	1.55	
CURRENT LIMIT	$V_{in} - V_o = 5\text{V}$ ($T_j = 25^{\circ}\text{C}$)	1000			mA
Minimum Load Current Adjustable Models	$V_{in} = 13.75\text{V}$			5	mA
QUIESCENT CURRENT	$V_{in} - V_o = 1.5\text{V}$		5.2	10	mA
Adjust Pin Current	$I_o = 10\text{mA}$, $V_{in} - V_o = 1.4$ to 10V		50	120	uA
vs Load Current, CBM1117C	$I_o = 10\text{mA}$ to 1A , $V_{in} - V_o = 1.4$ to 10V		0.5	5	uA
TEMPERATURE DRIFT	$T_j = -40^{\circ}\text{C}$ to $+125^{\circ}\text{C}$		0.5		%
RMS Output Noise	Bandwidth of 10Hz to 10kHz at 25°C		0.003		% V_o
Ripple Rejection Ratio	120Hz input Ripple(Cadj for ADJ) = $25\mu\text{F}$ $V_{in} - V_o = 5\text{V}$, $I_o = 1.0\text{A}$ $T_j = -40^{\circ}\text{C}$ to $+125^{\circ}\text{C}$	60	72		dB

Notes: (1) CBM1117C-X adjustable versions require a minimum load current for $\pm 3\%$ regulation.(2) Dropout voltage is the input voltage minus output voltage that produces a 1% decrease in output voltage.

BLOCK DIAGRAM

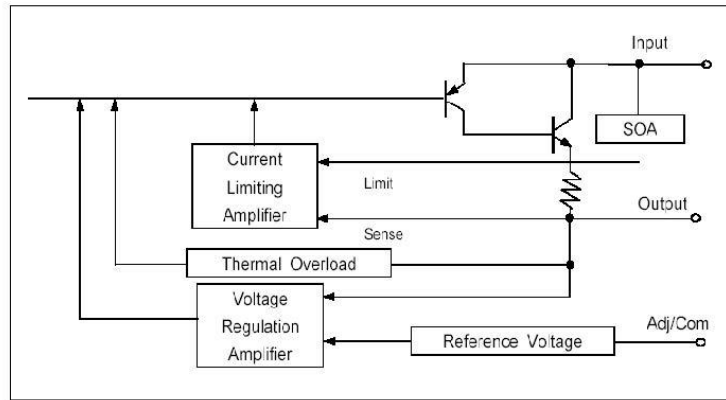

APPLICATION INFORMATION

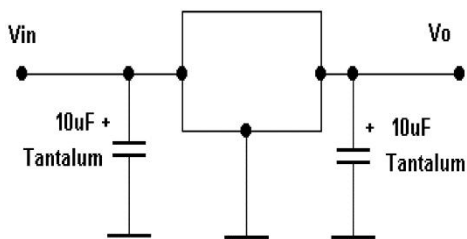

Fixed-Voltage Model
—Basic Connections.

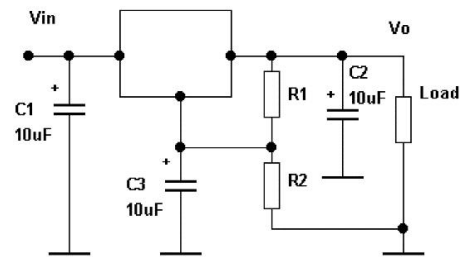

Adjustable-Voltage Model
--Basic Connections.

$$V_o = V_{ref}(1 + R_2/R_1) + I_{adj} \cdot R_2$$

TYPICAL PERFORMANCE CHARACTERISTICS

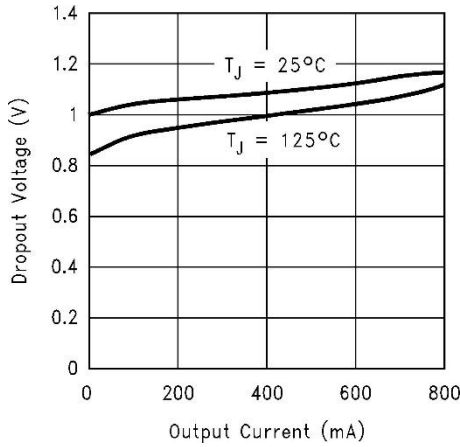

Dropout Voltage ($V_{IN} - V_{OUT}$)

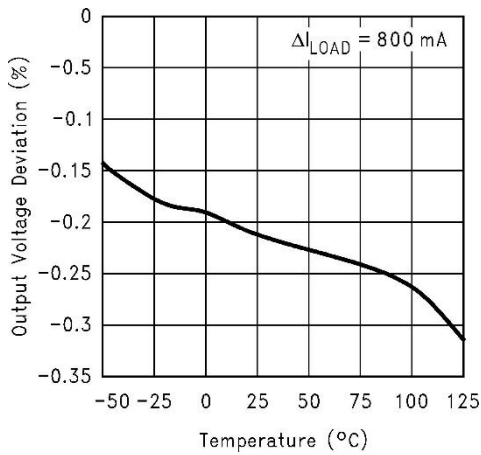

Load Regulation

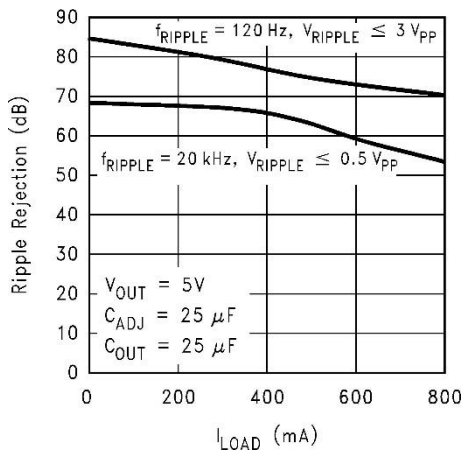

CBM1117C-ADJ Ripple Rejection vs Current

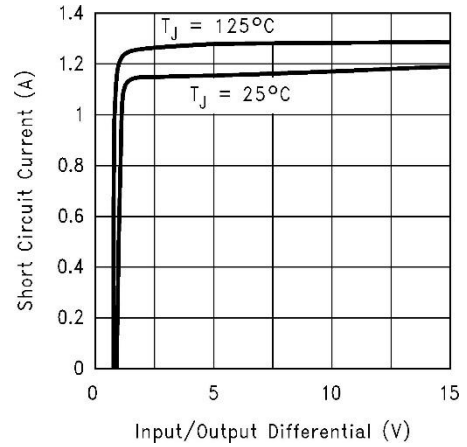

Short-Circuit Current

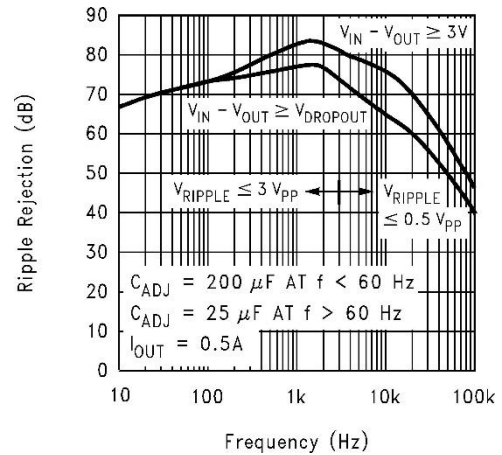

CBM1117C-ADJ Ripple Rejection

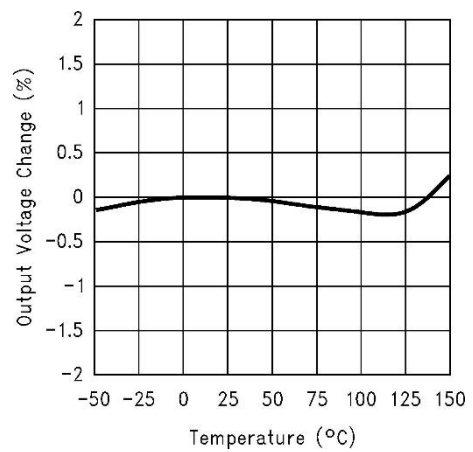

Temperature Stability

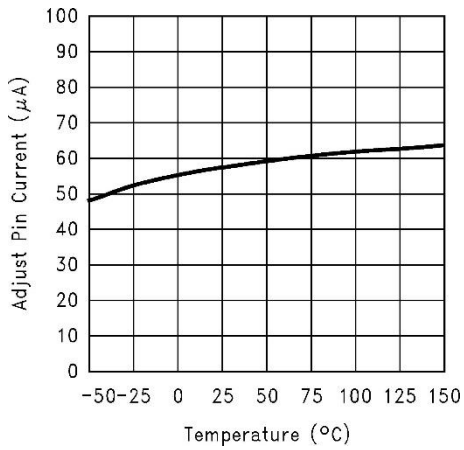

Adjust Pin Current

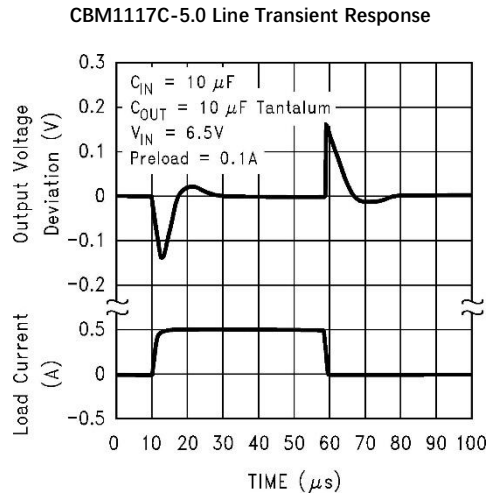
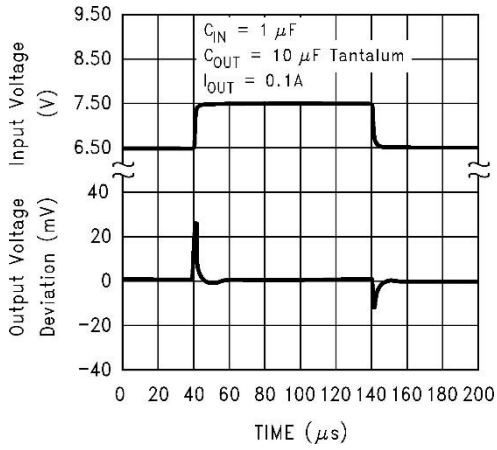

CBM1117C-5.0 Load Transient Response

Application Information

Output voltage adjustment

Like most regulators, the CBM1117C regulates the output by comparing the output voltage to an internally generated reference voltage. On the adjustable version as shown in Fig.4, the V_{REF} is available externally as 1.25V between V_{OUT} and ADJ. The voltage ratio formed by R1 and R2 should be set to conduct 10mA (minu-mum output load).

The output voltage is given by the following equation:

$$V_o = V_{ref}(1 + R_2/R_1) + I_{adj} * R_2$$

On fixed versions of CBM1117C, the voltage divider is provided internally

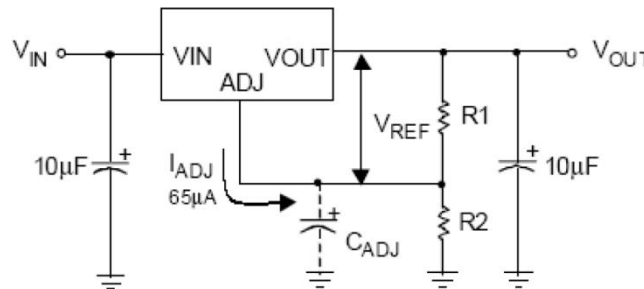

Figure 4. Basic Adjustable Regulator

Input Bypass Capacitor

An input capacitor is recommended. A 10µF tantalum on the input is a suitable input bypassing for almost all applications.

Adjust Terminal Bypass Capacitor

The adjust terminal can be bypassed to ground with a bypass capacitor (C_{ADJ}) to improve ripple rejection. This bypass capacitor prevents ripple from being amplified as the output voltage is increased. At any ripple frequency, the impedance of the C_{ADJ} should be less than R1 to prevent the ripple from being amplified:

$$(2\pi * f_{RIPPLE} * C_{ADJ}) < R_1$$

The R1 is the resistor between the output and the adjust pin. Its value is normally in the range of 100- 200Ω. For example, with $R_1 = 124\Omega$ and $f_{RIPPLE} = 120\text{Hz}$, the C_{ADJ} should be 11µF.

Output Capacitor

CBM1117C requires a capacitor from V_{OUT} to GND to provide compensation feedback to the internal gain stage. This is to ensure stability at the output terminal. Typically, a 10µF tantalum or 50µF aluminum electrolytic is sufficient.

Note: The ESR is typically 1.0 Ω.

The output capacitor does not have a theoretical upper limit and increasing its value will increase stability. $C_{OUT} = 100\mu\text{F}$ or more is typical for high current regulator design.

Load Regulation

When the adjustable regulator is used (Fig.5), the best load regulation is accomplished when the top of the resistor divider (R1) is connected directly to the output pin of the CBM1117C. When so connected, R_p is not multiplied by the divider ratio. For Fixed output version, the top of R1 is internally connected to the output and ground pins can be connected to low side of the load.

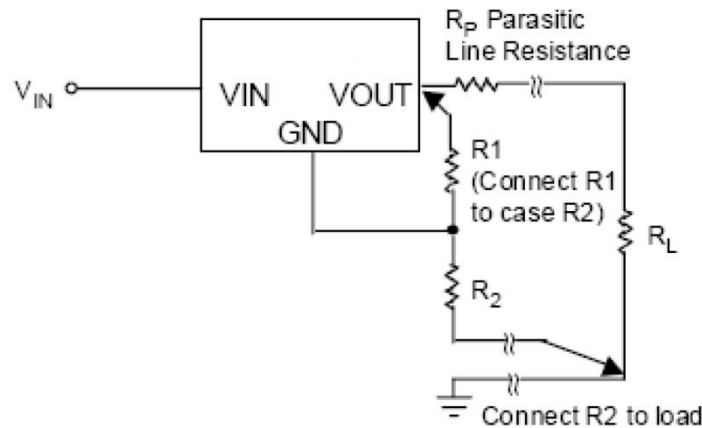

Figure 5. Best Load Regulation Using Adjustable Output Regulator

Thermal Protection

CBM1117C has thermal protection which limits junction temperature to 150°C. However, device functionality is only guaranteed to a maximum junction temperature of +125°C. The power dissipation and junction temperature for CBM1117C in DPAK package are given by

$$P_D = (V_{IN} - V_{OUT}) \times I_{OUT}$$

$$T_{JUNCTION} = T_{AMBIENT} + (P_D \times \theta_{JA})$$

Note: $T_{JUNCTION}$ must not exceed 125°C

Current Limit Protection

CBM1117C is protected against overload conditions. Current protection is triggered at typically 1.6A.

Thermal Consideration

The CBM1117C series contain thermal limiting circuitry designed to protect itself from over-temperature conditions. Even for normal load conditions, maximum junction temperature ratings must not be exceeded. As mention in thermal protection section, we need to consider all sources of thermal resistance between junction and ambient. It includes junction-to-case, case-to-heat-sink interface, and heat sink thermal resistance itself.

Junction-to-case thermal resistance is specified from the IC junction to the bottom of the case directly below the die. Proper mounting is required to ensure the best possible thermal flow from this area of the package to the heat sink. The case of all devices in this series is electrically connected to the output. Therefore, if the case of the device must be electrically isolated, a thermally conductive spacer is recommended.

PACKAGE

SOT-223

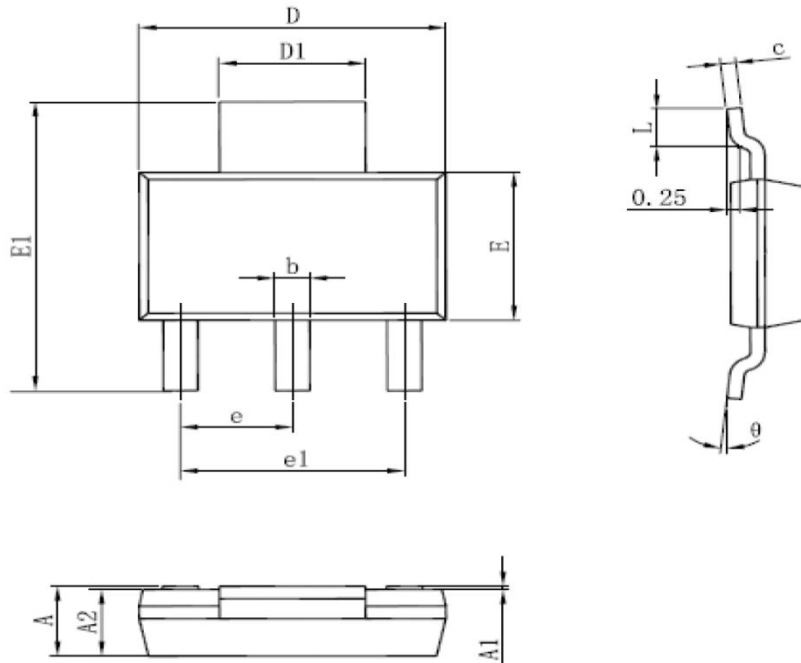

SYMBOL	DIMENSIONS IN MILLIMETERS		DIMENSIONS IN INCHES	
	MIN	MAX	MIN	MAX
A	1.520	1.800	0.060	0.071
A1	0.02	0.100	0.001	0.004
A2	1.500	1.700	0.059	0.067
b	0.660	0.810	0.026	0.032
c	0.240	0.320	0.010	0.014
D	6.300	6.500	0.248	0.256
D1	2.900	3.100	0.114	0.122
E	3.300	3.700	0.130	0.146
E1	6.830	7.070	0.269	0.278
e	2.300 BSC		0.091 BSC	
e1	4.500	4.700	0.177	0.185
L	0.900	1.150	0.035	0.048
θ	0°	10°	0°	10°

TO-263-3L

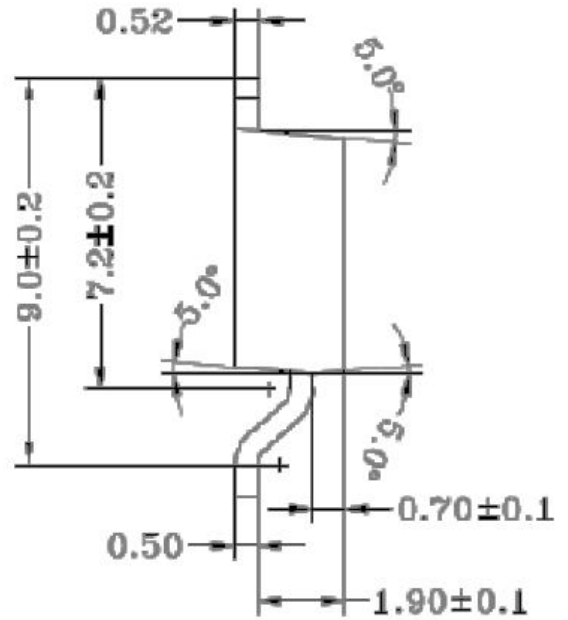
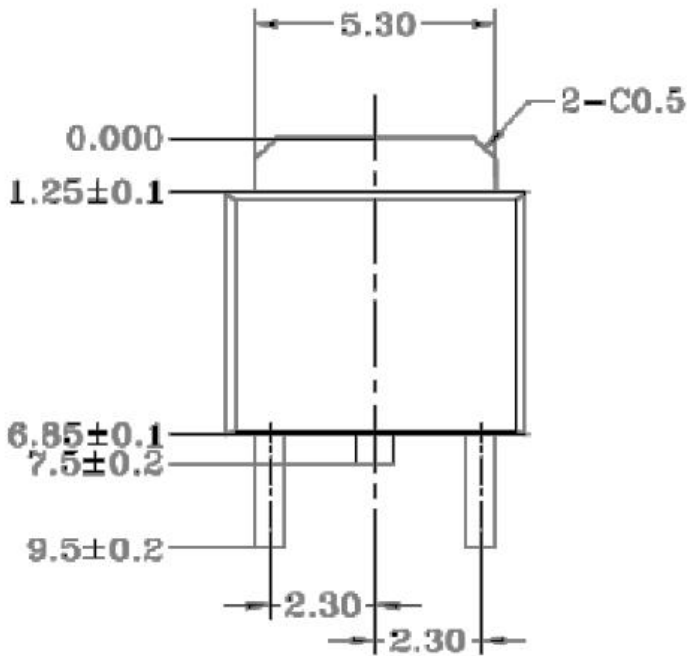
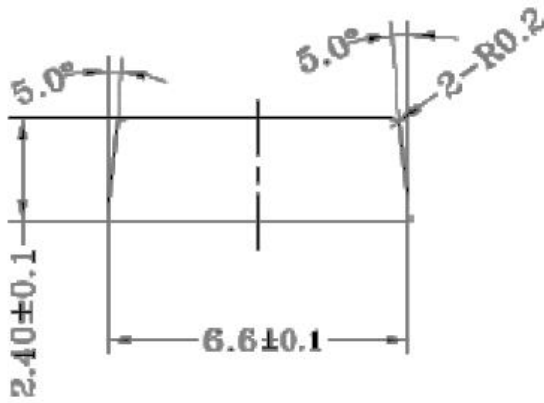

PACKAGE/ORDERING INFORMATION

PRODUCT	ORDERING NUMBER	TEMPRANGE	PACKAGE	PAKEAGE MARKING	TRANSPOT MEDIA,QUANTILY
CBM1117	CBM1117C-1.2	-40°C~125°C	SOT223-3 TO-263-3	117-12	Tape and Reel,2500
	CBM1117C-1.25(ADJ)	-40°C~125°C	SOT223-3 TO-263-3	117-125	Tape and Reel,2500
	CBM1117C-1.5	-40°C~125°C	SOT223-3 TO-263-3	117-15	Tape and Reel,2500
	CBM1117C-1.8	-40°C~125°C	SOT223-3 TO-263-3	117-18	Tape and Reel,2500
	CBM1117C-2.5	-40°C~125°C	SOT223-3 TO-263-3	117-25	Tape and Reel,2500
	CBM1117C-3.3	-40°C~125°C	SOT223-3 TO-263-3	117-33	Tape and Reel,2500
	CBM1117C-5.0	-40°C~125°C	SOT223-3 TO-263-3	117-50	Tape and Reel,2500

X-ON Electronics

Largest Supplier of Electrical and Electronic Components

Click to view similar products for [Linear Voltage Regulators](#) category:

Click to view products by [Corebai Microelectronics](#) manufacturer:

Other Similar products are found below :

[LV5684PVD-XH](#) [MCDTSA6-2R](#) [L7815ACV-DG](#) [LV56801P-E](#) [UA7805CKC](#) [714954EB](#) [ZMR500QFTA](#) [BA033LBSG2-TR](#)

[NCV78M05ABDTRKG](#) [LV5680P-E](#) [L79M05T-E](#) [L78LR05D-MA-E](#) [NCV317MBTG](#) [NTE7227](#) [MP2018GZD-33-P](#) [MP2018GZD-5-P](#)

[LV5680NPVC-XH](#) [ZTS6538SE](#) [UA78L09CLP](#) [UA78L09CLPR](#) [CAT6221-PPTD-GT3](#) [MC78M09CDTRK](#) [NCV51190MNTAG](#)

[BL1118CS8TR1833](#) [BL8563CKETR18](#) [BL8077CKETR33](#) [BL9153-33CC3TR](#) [BL9161G-15BADRN](#) [BL9161G-28BADRN](#)

[BRCO7530MMC](#) [CJ7815B-TFN-ARG](#) [LM317C](#) [GM7333K](#) [GM7350K](#) [XC6206P332MR](#) [HT7533](#) [LM7912S/TR](#) [LT1764S/TR](#) [LM7805T](#)

[LM338T](#) [LM1117IMP-3.3/TR](#) [HT1117AM-3.3](#) [HT7550S](#) [AMS1117-3.3](#) [HT7150S](#) [78L12](#) [HT7550](#) [HT7533-1](#) [HXY6206I-2.5](#) [HT7133](#)