

FEATURES

- 3.3V, 5V, 12V, and adjustable output versions
- Adjustable version output voltage range, 1.2V to 37V \pm 4% max over line and load conditions
- Guaranteed 3A output load current
- Input voltage range up to 40V
- Requires only 4 external components
- Excellent line and load regulation specifications
- 150kHz fixed frequency internal oscillator
- TTL shutdown capability
- Low power standby mode, I_Q typically 100 μ A
- Thermal shutdown and current limit protection

APPLICATIONS

- Simple high-efficiency step-down regulator
- On-card switching regulators
- Positive to negative converter

GENERAL DESCRIPTION

The CBM2596 series of regulators are monolithic integrated circuits that provide all the active functions for a step-down switching regulator, capable of driving a 3A load with excellent line and load regulation. These devices are available in fixed output voltages of 3.3V, 5V, 12V and an adjustable output version.

Requiring a minimum number of external components, these regulators are simple to use.

The CBM2596 series operates at a switching frequency of 150kHz. Available in standard 5-lead TO-220 package.

Other features include a guaranteed \pm 4% tolerance on output voltage under specified input voltage and output load conditions, and \pm 15% on the oscillator frequency. External shutdown is included, featuring typically 100 μ A standby current. Self protection features include a two stage frequency reducing current limit for output switch and an over temperature shutdown for complete protection under fault conditions. The over temperature shutdown level is about 145 $^{\circ}$ C with 5 $^{\circ}$ C hysteresis.

ABSOLUTE MAXIMUM RATINGS

(Absolute Maximum Ratings indicate limits beyond which damage to the device may occur.)

Rating	Symbol	Value	Unit
Maximum Input Supply Voltage	V_I	45V	V
ON/OFF Pin Input Voltage	V_{IN}	$-0.3V \leq V \leq +25V$	V
Feedback Pin Voltage	-	$-0.3V \leq V \leq +25V$	V
Output Voltage to Ground	V_O	-1V	V
Power Dissipation	P_D	Internally limited	W
Storage Temperature Range	T_{stg}	$-65^{\circ}C$ to $+150^{\circ}C$	$^{\circ}C$
Operating Temperature Range	T_J	$40^{\circ}C \leq T_J \leq +125^{\circ}C$	$^{\circ}C$
Operating Supply Voltage	V_{IN}	4.5V to 40V	V

* Stresses beyond those listed under “absolute maximum ratings” may cause permanent damage to the device. These are stress ratings only and functional operation of the device at these or any other conditions beyond those indicated under “recommended operating conditions” is not implied.

Exposure to absolute-maximum-rated conditions for extended periods may affect device reliability.

Typical Application (Fixed Output Voltage Versions)

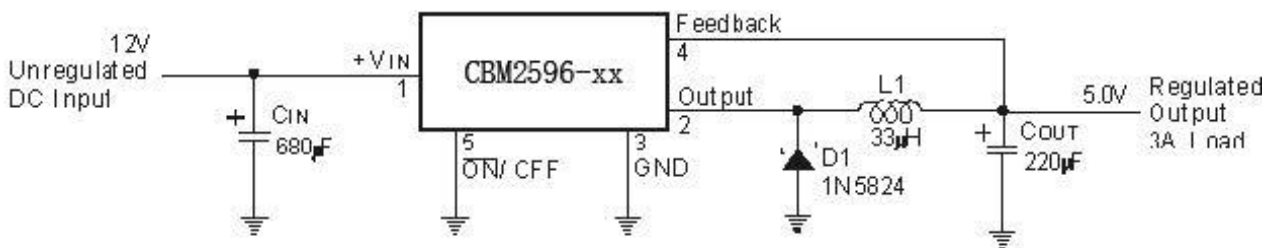

ELECTRICAL CHARACTERISTICS

Unless otherwise specified, $T_J = 25^{\circ}C$, $V_{IN} = 12V$ for the 3.3V, 5V, and Adjustable version and $V_{IN} = 24V$ for the 12V version. $I_{LOAD} = 500mA$.

Characteristic	Symbol	Test Condition		Min	Typ	Max	Unit
Output Voltage	V _{OUT}	CBM2596-3	4.75V ≤ V _{IN} ≤ 40V, 0.2A ≤ I _{LOAD} ≤ 3A	3.168	3.3	3.432	V
		CBM2596-5	7V ≤ V _{IN} ≤ 40V, 0.2A ≤ I _{LOAD} ≤ 3A	4.8	5.0	5.2	
		CBM2596-12	15V ≤ V _{IN} ≤ 40V, 0.2A ≤ I _{LOAD} ≤ 3A	11.52	12.0	12.48	
Efficiency	η	CBM2596-3	I _{LOAD} = 3A		73		%
		CBM2596-5	I _{LOAD} = 3A		80		
		CBM2596-12	V _{IN} = 25V, I _{LOAD} = 3A		90		
		CBM2596-A	V _{OUT} = 3V, I _{LOAD} = 3A		73		
Feedback Voltage	V _{FB}	CBM2596-A	4.5V ≤ V _{IN} ≤ 40V, 0.2A ≤ I _{LOAD} ≤ 3A V _{OUT} programmed for 3V	1.193	1.230	1.267	V
Feedback Bias Current	I _D	CBM2596-A	V _{FB} = 1.3V		15	50	nA
Oscillator Frequency	f _O			110	150	173	kHz
Saturation Voltage	V _{SAT}	I _{OUT} = 3A(Note 1,2)			1.16	1.4	V
Max Duty Cycle (ON)	DC	(Note 2)			100		%
Max Duty Cycle (OFF)		(Note 3)			0		
Current Limit	I _{CL}	Peak Current(Note 1,2)		3.4	4.5	6.0	A
Output Leakage Current	I _L	Output = 0V(Note 1,3)				50	μA
		Output = -1V, V _{IN} = 40V			2	30	mA
Quiescent Current	I _Q	(Note 3)			5	10	mA
Standby Quiescent Current	I _{STBY}	ON/OFF pin = 5V (OFF), V _{IN} = 40V			100	200	μA
ON/OFF Pin Logic Input Threshold Voltage	V _{IH}	Low (Regulator ON)		2.0	1.3	0.6	V
	V _{IL}	High (Regulator OFF)					
ON/OFF Pin Input Current	I _H	V _{LOGIC} = 2.5V (regulator OFF)			5	15	μA
	I _L	V _{LOGIC} = 0.5V (regulator ON)			0.02	5	

Note 1: No elements connected to output pin.

Note 2: Feedback pin removed from output and connected to 0V to force the output transistor switch ON.

Note 3: Feedback pin removed from output and connected to 12V for the 3.3V, 5V, and the A version, and 15V for the 12V version. To force the output transistor switch OFF.

Typical Performance Characteristics

Iccz vs Tpkg (TO-220)

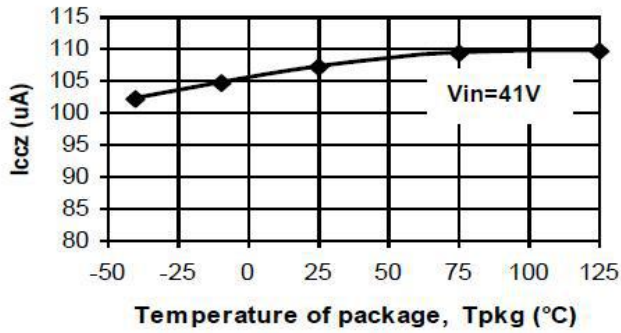

Vds vs Tpkg (TO-220)

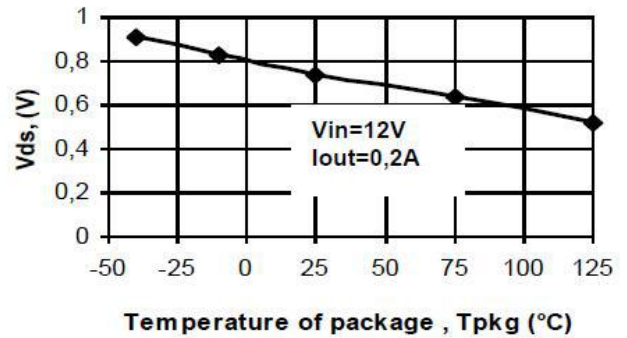

Ib (on 4 pin) vs Tpkg (TO-220)

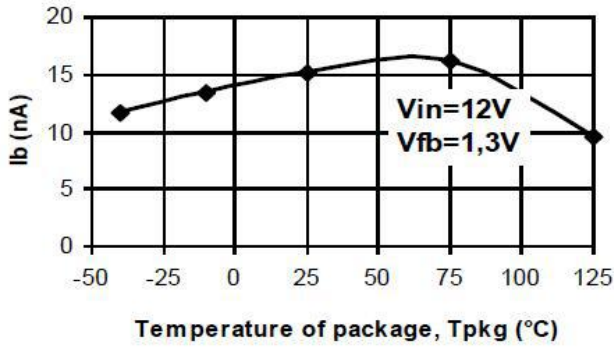

CBM2596-adj Vfb vs Tpkg (TO-220)

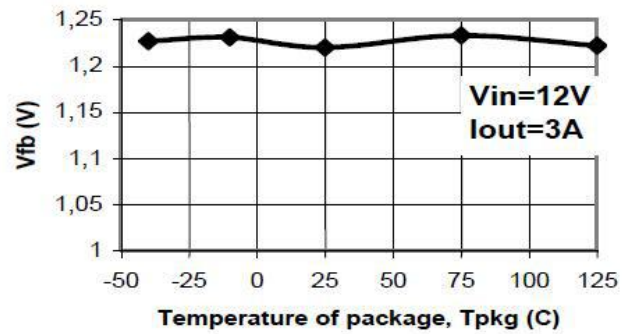

Frequency F vs Tpkg (TO-220)

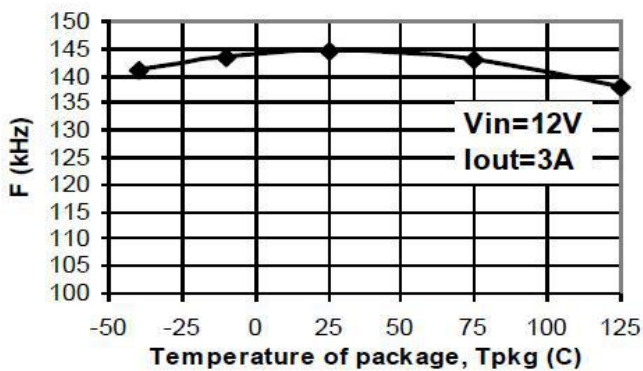

CBM2596-3.3 Vo vs Tpkg

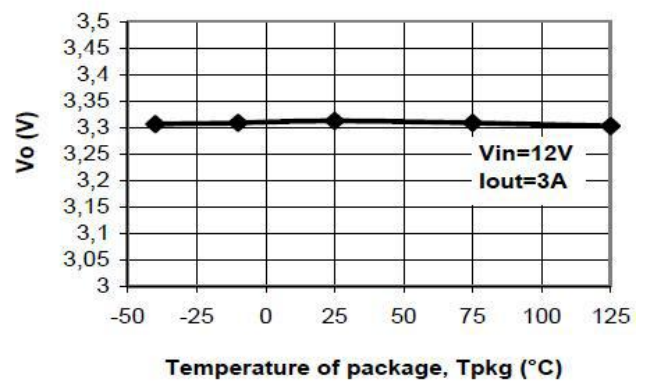

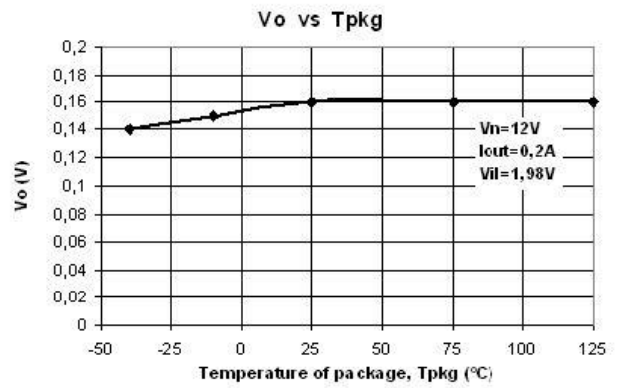
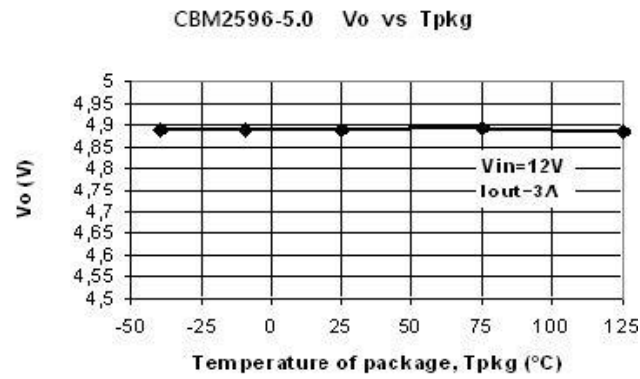
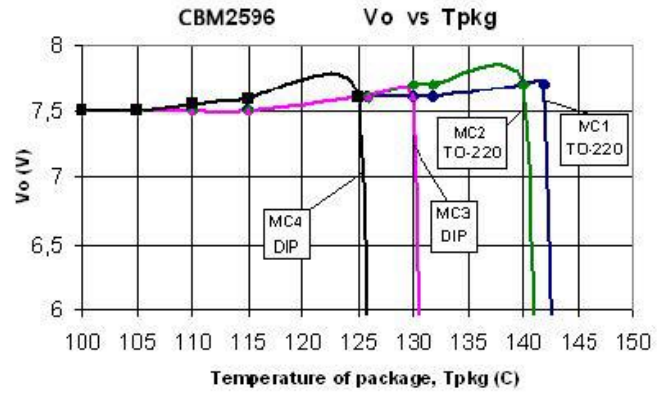
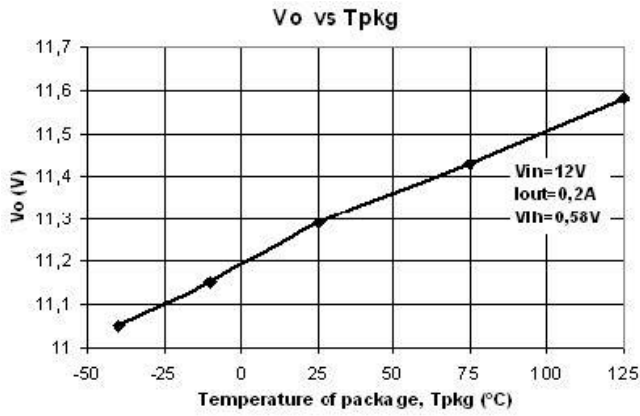

Test Circuits

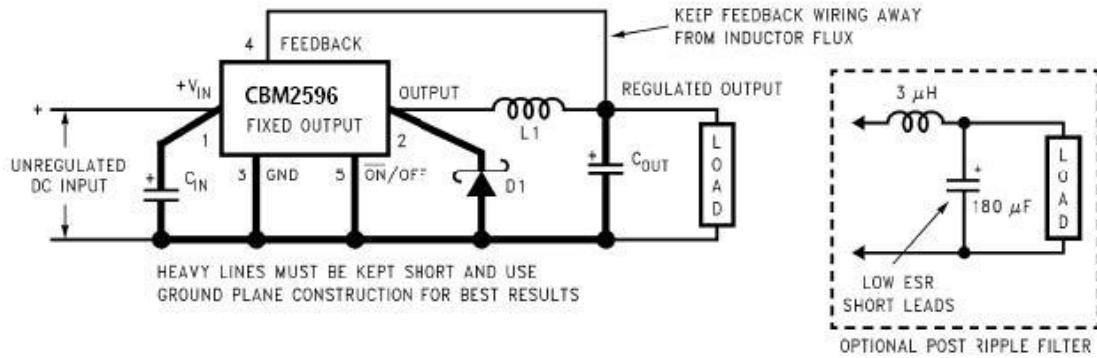

Figure1. Standard Test Circuit for Fixed Output Voltage Versions

- C_{IN} —470 μF, 50V, Aluminum Electrolytic Nichicon “PL Series”
- C_{OUT} —220 μF, 25V Aluminum Electrolytic, Nichicon “PL Series”
- D₁ —5A, 40V Schottky Rectifier, 1N5825
- L₁ —68 μH, L38

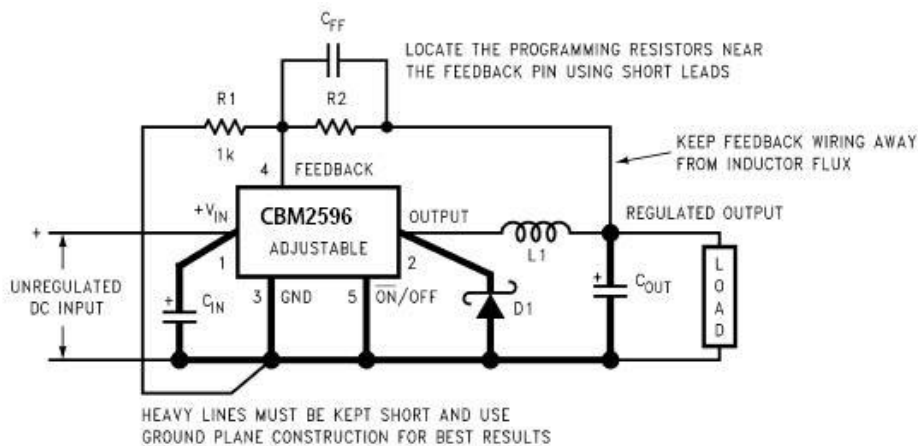

Figure 2. Standard Test Circuit for Adjustable Output Voltage Versions

where $V_{REF} = 1.23V$ $V_{OUT} = V_{REF} \left(1 + \frac{R_2}{R_1}\right)$ $R_2 = R_1 \left(\frac{V_{OUT}}{V_{REF}} - 1\right)$

Select R₁ to be approximately 1 kW, use a 1% resistor for best stability.

- C_{IN} —470 μF, 50V, Aluminum Electrolytic Nichicon “PL Series”
- C_{OUT} —220 μF, 35V Aluminum Electrolytic, Nichicon “PL Series”
- D₁ —5A, 40V Schottky Rectifier, 1N5825
- L₁ —68μH, L38
- R₁ —1kW, 1%
- $C_{FF} = \frac{1}{31 \times 10^3 \times R_2}$

Application Information

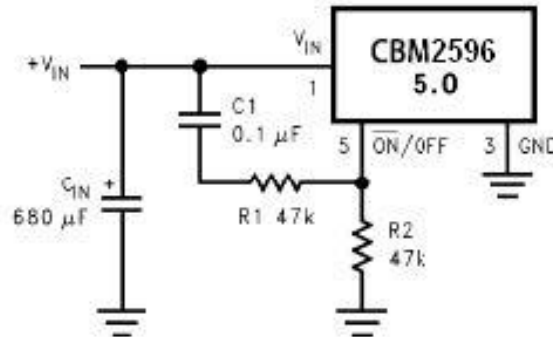

Figure 3. Delayed Startup

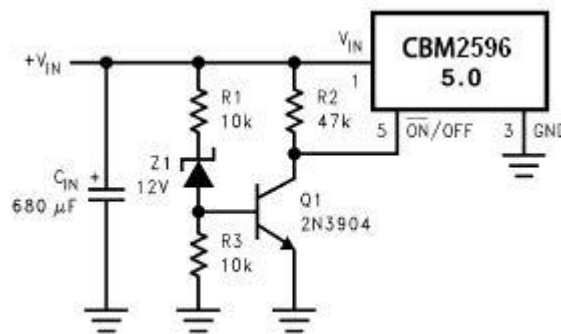

Figure 4. Undervoltage Lockout for Buck Regulator

DELAYED STARTUP

The circuit in Figure 3 uses the the ON /OFF pin to provide a time delay between the time the input voltage is applied and the time the output voltage comes up (only the circuitry pertaining to the delayed start up is shown). As the input voltage rises, the charging of capacitor C1 pulls the ON /OFF pin high, keeping the regulator off. Once the input voltage reaches its final value and the capacitor stops charging, and resistor R2 pulls the ON /OFF pin low, thus allowing the circuit to start switching. Resistor R1 is included to limit the maximum voltage applied to the ON /OFF pin (maximum of 25V), reduces power supply noise sensitivity, and also limits the capacitor, C1, discharge current. When high input ripple voltage exists, avoid long delay time, because this ripple can be coupled into the ON /OFF pin and cause problems. This delayed startup feature is useful in situations where the input power source is limited in the amount of current it can deliver. It allows the input voltage to rise to a higher voltage before the regulator starts operating. Buck regulators require less input current at higher input voltages.

UNDERVOLTAGE LOCKOUT

Some applications require the regulator to remain off until the input voltage reaches a predetermined voltage. An undervoltage lockout feature applied to a buck regulator is shown in Figure 4, while Figure 5 and 6 applies the same feature to an inverting circuit. The circuit in Figure 5 features a constant threshold voltage for turn on and turn off (zener voltage plus approximately one volt). If hysteresis is needed, the circuit in Figure 6 has a turn ON voltage which is different than the turn OFF voltage. The amount of hysteresis is approximately equal to the value of the output voltage. If zener voltages greater than 25V are used, an additional 47 k resistor is needed from the ON /OFF pin to the ground pin to stay within the 25V maximum limit of the ON /OFF pin.

INVERTING REGULATOR

The circuit in Figure 7 converts a positive input voltage to a negative output voltage with a common ground. The circuit operates by bootstrapping the regulator's ground pin to the negative output voltage, then grounding the feedback pin, the regulator senses the inverted output voltage and regulates it.

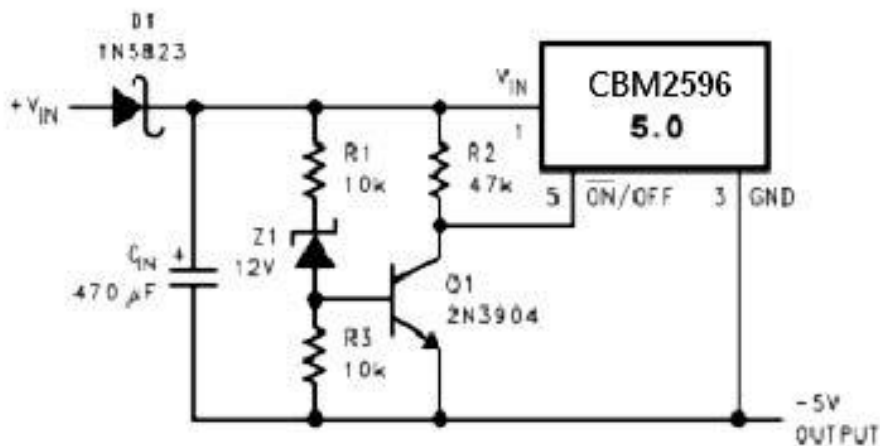

This circuit has an ON/OFF threshold of approximately 13V.

Figure 5. Undervoltage Lockout for Inverting Regulator

This example uses the CBM2596-5.0 to generate a $-5V$ output, but other output voltages are possible by selecting other output voltage versions, including the adjustable version. Since this regulator topology can produce an output voltage that is either greater than or less than the input voltage, the maximum output current greatly depends on both the input and output voltage. The curve shown in Figure 8 provides a guide as to the amount of output load current possible for the different input and output voltage conditions.

The maximum voltage appearing across the regulator is the absolute sum of the input and output voltage, and this must be limited to a maximum of $40V$. For example, when converting $+20V$ to $-12V$, the regulator would see $32V$ between the input pin and ground pin. The CBM2596 has a maximum input voltage spec of $40V$.

Additional diodes are required in this regulator configuration. Diode D1 is used to isolate input voltage ripple or noise from coupling through the C_{IN} capacitor to the output, under light or no load conditions. Also, this diode isolation changes the topology to closely resemble a buck configuration thus providing good closed loop stability. A Schottky diode is recommended for low input voltages, (because of its lower voltage drop) but for higher input voltages, a fast recovery diode could be used.

Without diode D3, when the input voltage is first applied, the charging current of C_{IN} can pull the output positive by several volts for a short period of time. Adding D3 prevents the output from going positive by more than a diode voltage.

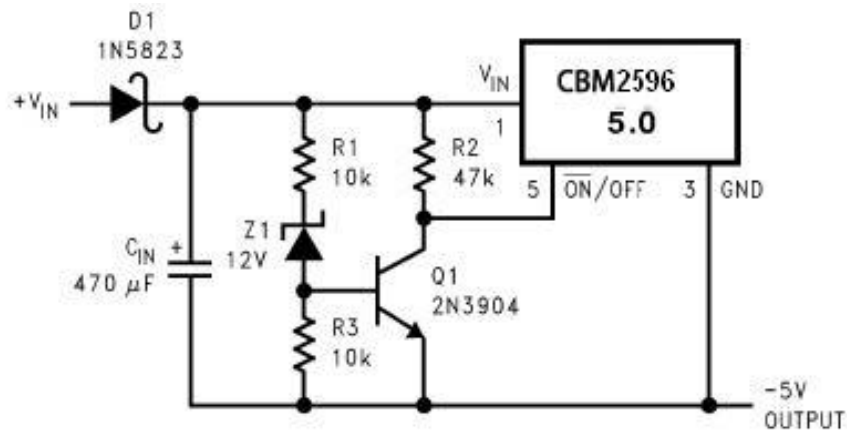

Figure 6. Undervoltage Lockout with Hysteresis for Inverting Regulator

This circuit has hysteresis

Regulator starts switching at $V_{IN} = 13V$

Regulator stops switching at $V_{IN} = 8V$

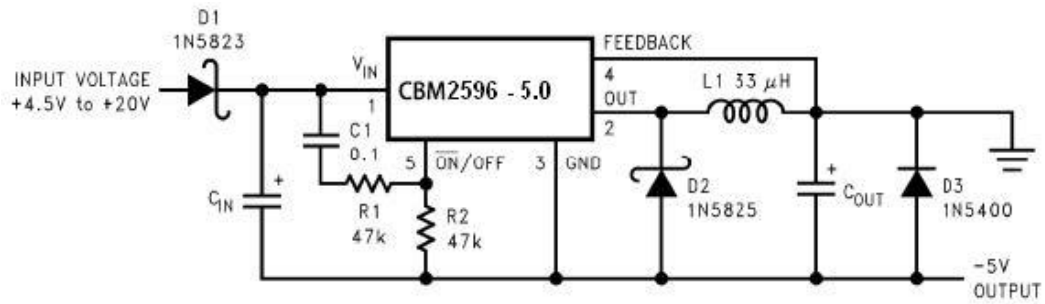

Figure 7. Inverting -5V Regulator with Delayed Startup

CIN —68 μ F/25V Tant. Sprague 595D

470 μ F/50V Elec. Panasonic HFQ

COU —47 μ F/20V Tant. Sprague 595D

220 μ F/25V Elec. Panasonic HFQ

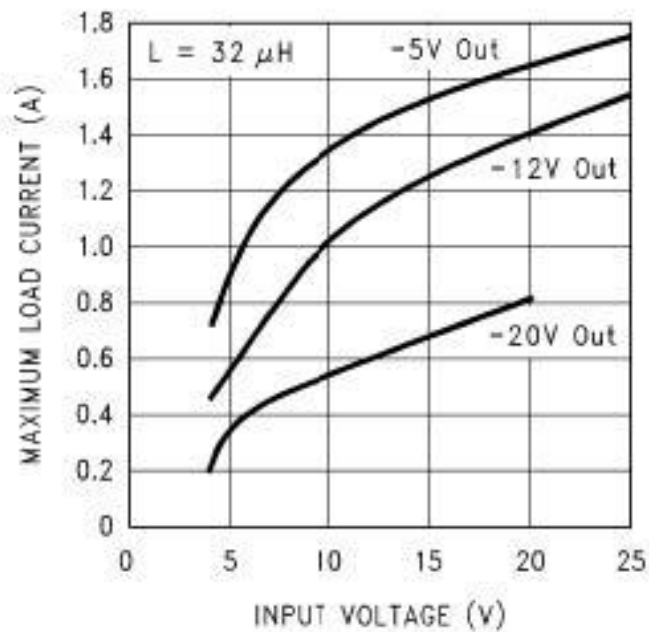

Figure 8. Inverting Regulator Typical Load Current

Because of differences in the operation of the inverting regulator, the standard design procedure is not used to select the inductor value. In the majority of designs, a 33 μ H, 3.5A inductor is the best choice. Capacitor selection can also be narrowed down to just a few values. Using the values shown in Figure 7 will provide good results in the majority of inverting designs.

This type of inverting regulator can require relatively large amounts of input current when starting up, even with light loads. Input currents as high as the CBM2596 current limit (approx 4.5A) are needed for at least 2ms or more, until the output reaches its nominal output voltage. The actual time depends on the output voltage and the size of the output capacitor. Input power sources that are current limited or sources that can not deliver these currents without getting loaded down, may not work correctly. Because of the relatively high startup currents required by the inverting topology, the delayed startup feature (C_1 , R_1 and R_2) shown in Figure 7 is recommended. By delaying the regulator startup, the input capacitor is allowed to charge up to a higher voltage before the switcher begins operating. A portion of the high input current needed for startup is now supplied by the input capacitor (C_{IN}). For severe start up conditions, the input capacitor can be made much larger than normal.

INVERTING REGULATOR SHUTDOWN METHODS

To use the ON /OFF pin in a standard buck configuration is simple, pull it below 1.3V (@25°C, referenced to ground) to turn regulator ON, pull it above 1.3V to shut the regulator OFF. With the inverting configuration, some level shifting is required, because the ground pin of the regulator is no longer at ground, but is now setting at the negative output voltage level. Two different shutdown methods for inverting regulators are shown in Figure 9 and Figure 10.

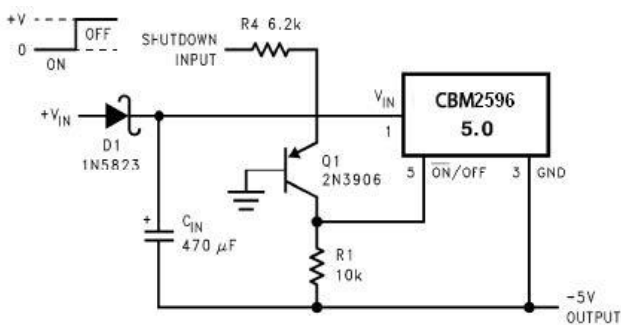

Figure 9. Inverting Regulator Ground Referenced Shutdown

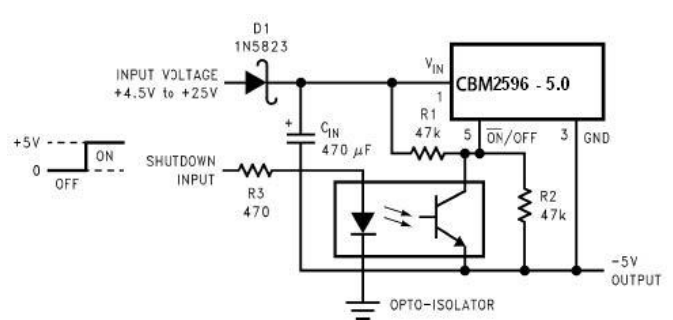
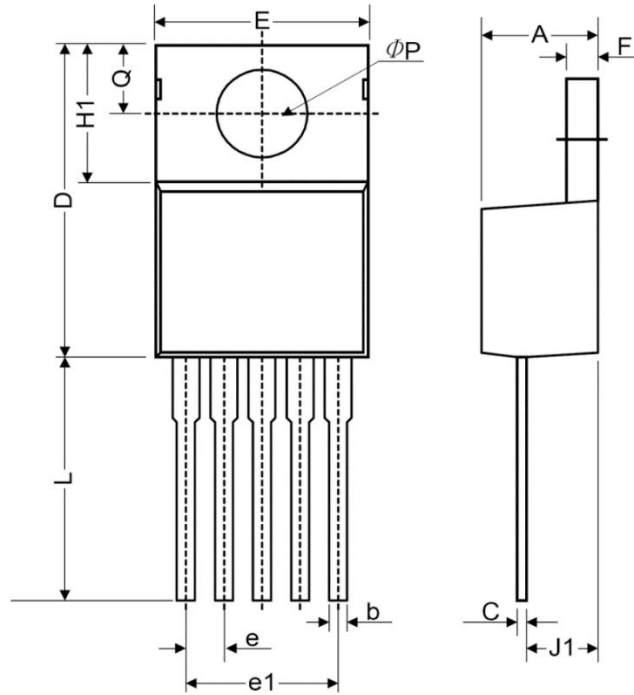

Figure 10. Inverting Regulator Ground Referenced Shutdown using Opto Device

PACKAGE

TO-220-5L



Symbol	Dimensions In Millimeters			Dimensions Inches		
	Min	Nom	Max	Min	Nom	Max
A	4.07	4.45	4.82	0.160	0.175	0.190
b	0.76	0.89	1.02	0.030	0.035	0.040
C	0.36	0.50	0.64	0.014	0.020	0.025
D	14.22	14.86	15.50	0.560	0.585	0.610
E	9.78	10.16	10.54	0.385	0.400	0.415
e	1.57	1.71	1.85	0.062	0.067	0.073
e1	6.68	6.81	6.93	0.263	0.268	0.273
F	1.14	1.27	1.40	0.045	0.050	0.055
H1	5.46	6.16	6.86	0.215	0.243	0.270
J1	2.29	2.74	3.18	0.090	0.108	0.125
L	13.21	13.97	14.73	0.520	0.550	0.580
ϕp	3.68	3.81	3.94	0.145	0.150	0.155
Q	2.54	2.73	2.92	0.100	0.107	0.115

TO-263-5L

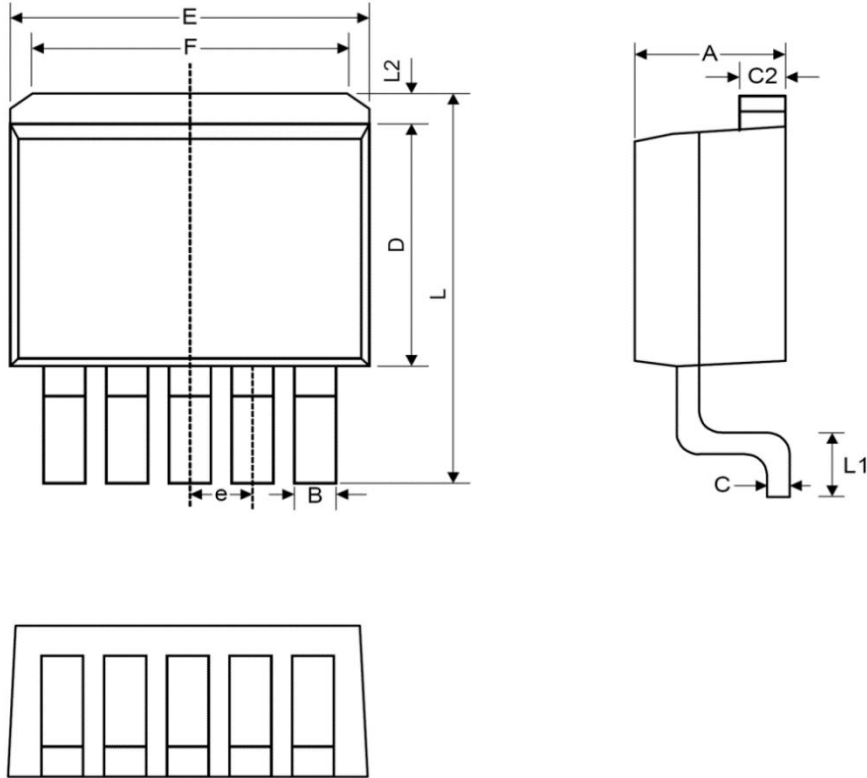

Symbol	Dimensions In Millimeters			Dimensions Inches		
	Min	Nom	Max	Min	Nom	Max
A	4.07	4.46	4.85	0.160	0.176	0.191
B	0.66	0.84	1.02	0.026	0.033	0.040
C	0.36	0.50	0.64	0.014	0.020	0.025
C2	1.14	1.27	1.40	0.045	0.050	0.055
D	8.65	9.15	9.65	0.341	0.360	0.380
E	9.78	10.16	10.54	0.385	0.400	0.415
e	1.57	1.71	1.85	0.062	0.068	0.073
F	6.60	6.86	7.11	0.260	0.270	0.280
L	14.61	15.24	15.88	0.575	0.600	0.625
L1	2.29	2.54	2.79	0.090	0.100	0.110
L2	-	-	2.92	-	-	0.115

TO-220-5L (Bent Staggered)

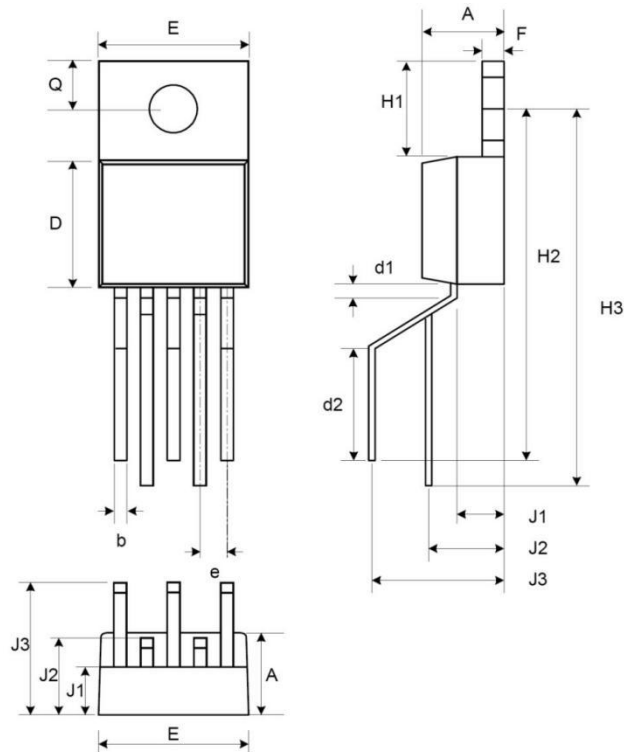

Symbol	Dimensions In Millimeters			Dimensions Inches		
	Min	Nom	Max	Min	Nom	Max
A	4.4	4.6	4.7	0.175	0.180	0.185
b	0.7	0.8	0.9	0.027	0.032	0.037
D	8.4	8.7	8.9	0.330	0.340	0.350
d1	1.0			0.039		
d2	6.3			0.248		
E	9.91	10.16	10.41	0.390	0.400	0.410
e	1.6	1.7	1.8	0.062	0.067	0.072
F	1.2	1.25	1.3	0.048	0.050	0.052
H1	6.4			0.250		
H2	20.8	21.6	22.4	0.820	0.850	0.880
J1	2.7			0.105		
J2	3.9	4.5	5.3	0.147	0.177	0.207
J3	8.4			0.331		
Q	2.5	2.8	3.0	0.100	0.110	0.120

PACKAGE/ORDERING INFORMATION

PRODUCT	ORDERING NUMBER	TEMPRANGE	PACKAGE	PAKEAGE MARKING	TRANSPOT MEDIA,QUANTILY
CBM2596	CBM2596T-ADJ	-40°C~125°C	TO-220	2596T-ADJ	Tape and Reel,46
	CBM2596DT-ADJ	-40°C~125°C	TO-263-5	2596DT-ADJ	Tape and Reel,500
CBM2596-3.3	CBM2596T-3.3	-40°C~125°C	TO-220	2596T-3.3	Tape and Reel,46
	CBM2596DT-3.3	-40°C~125°C	TO-263-5	2596DT-3.3	Tape and Reel,500
CBM2596-5.0	CBM2596T-5.0	-40°C~125°C	TO-220	2596T-5.0	Tape and Reel,46
	CBM2596DT-5.0	-40°C~125°C	TO-263-5	2596DT-5.0	Tape and Reel,500
CBM2596-12	CBM2596T-12	-40°C~125°C	TO-220	2596T-12	Tape and Reel,46
	CBM2596DT-12	-40°C~125°C	TO-263-5	2596DT-12	Tape and Reel,500

X-ON Electronics

Largest Supplier of Electrical and Electronic Components

Click to view similar products for [Isolated DC/DC Converters](#) category:

Click to view products by [Corebai Microelectronics](#) manufacturer:

Other Similar products are found below :

[ESM6D044440C05AAQ](#) [FMD15.24G](#) [PSL486-7LR](#) [PSR152.5-7IR](#) [Q48T30020-NBB0](#) [AVO240-48S12B-6L](#) [AVO250-48S28B-6L](#) [NAN-0505](#) [HW-L16D](#) [JAHW100Y1](#) [217-1617-001](#) [22827](#) [SPB05C-12](#) [SQ24S15033-PS0S](#) [18952](#) [19-130041](#) [CE-1003](#) [CE-1004](#) [GQ2541-7R](#) [PSE1000DCDC-12V](#) [RDS180245](#) [MAU228](#) [419-2065-201](#) [449-2075-101](#) [J80-0041NL](#) [V300C24C150BG](#) [419-2062-200](#) [419-2063-401](#) [419-2067-101](#) [419-2067-501](#) [419-2068-001](#) [DCG40-5G](#) [DFC15U48D15](#) [449-2067-000](#) [XGS-0512](#) [XGS-1205](#) [XGS-1212](#) [XGS-2412](#) [XGS-2415](#) [XKS-1215](#) [033456](#) [NCT1000N040R050B](#) [SPB05B-15](#) [SPB05C-15](#) [SSQE48T25025-NAA0G](#) [L-DA20](#) [HP3040-9RG](#) [HP1001-9RTG](#) [XKS-2415](#) [XKS-2412](#)