

FEATURES

- 300 μ A SUPPLY CURRENT
- 120Kbps MAX GUARENTEED DATA RATE
- 3V/ μ s MINIMUM GUARANTEED SLEW RATE
- ENHANCED ESD SPECIFICATIONS:
 \pm 15kV IEC61000-4-2 Air Discharge
 \pm 8kV IEC61000-4-2 Contact Discharge
- AVAILABLE IN SO-16,TSSOP16 AND SOP16L(W)

APPLICATIONS

- Battery-Powered Equipment
- Hand-Held Equipment
- Peripherals
- Datacom Equipment

GENERAL DESCRIPTION

The CBM3232 is a 3.3V powered EIA/TIA-232 and V.28/V.24 communication interface with low power requirements, high data-rate capabilities. CBM3232 has a proprietary low dropout transmitter output stage providing true RS-232 performance from 3.3V to 5.5V supplies. The device requires only four small 0.1 μ F standard external capacitors for operations from 3.3V supply.

The CBM3232 has two receivers and two drivers. The device is guaranteed to run at data rates of 120Kbps while maintaining RS-232 output levels. Typical applications are Notebook, Subnotebook and Palmtop Computers, Battery Powered Equipment, Hand-Held Equipment, Peripherals and Printers.

PIN CONFIGURATION

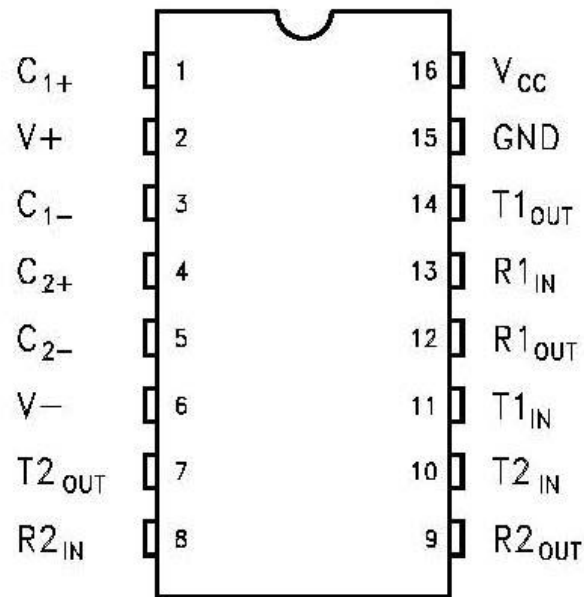

PIN DESCRIPTION

PIN N°	SYMBOL	NAME AND FUNCTION
1	C_{1+}	Positive Terminal for the first Charge Pump Capacitor
2	$V+$	Doubled Voltage Terminal
3	C_1	Negative Terminal for the first Charge Pump Capacitor
4	C_{2+}	Positive Terminal for the second Charge Pump Capacitor
5	C_2	Negative Terminal for the second Charge Pump Capacitor
6	$V-$	Inverted Voltage Terminal
7	$T2_{OUT}$	Second Transmitter Output Voltage
8	$R2_{IN}$	Second Receiver Input Voltage
9	$R2_{OUT}$	Second Receiver Output Voltage
10	$T2_{IN}$	Second Transmitter Input Voltage
11	$T1_{IN}$	First Transmitter Input Voltage
12	$R1_{OUT}$	First Receiver Output Voltage
13	$R1_{IN}$	First Receiver Input Voltage
14	$T1_{OUT}$	First Transmitter Output Voltage
15	GND	Ground
16	V_{CC}	Supply Voltage

ABSOLUTE MAXIMUM RATING

Symbol	Parameter	Value	Unit
V _{CC}	Supply Voltage	-0.3 to 6	V
V+	Doubled Voltage Terminal	(V _{CC} - 0.3) to 7	V
V-	Inverted Voltage Terminal	0.3 to -7	V
V+ + V-		13	V
T _{IN}	Transmitter Input Voltage Range	-0.3 to 6	V
R _{IN}	Receiver Input Voltage Range	± 25	V
T _{OUT}	Transmitter Output Voltage Range	± 13.2	V
R _{OUT}	Receiver Output Voltage Range	-0.3 to (V _{CC} + 0.3)	V
T _a	Operating Temperature	-40 to 85	°C
T _s	Storage Temperature	-60 to 150	°C
t _{SHORT}	Transmitter Output Short to GND Time	Continuous	

* Stresses beyond those listed under “absolute maximum ratings” may cause permanent damage to the device.

These are stress ratings only and functional operation of the device at these or any other conditions beyond those indicated under “recommended operating conditions” is not implied.

Exposure to absolute-maximum-rated conditions for extended periods may affect device reliability.

V+ and V-can have a maximum magnitude of +7V, but their absolute addition cannot exceed 13 V.

ELECTRICAL CHARACTERISTICS

($C_1 - C_4 = 0.1\mu\text{F}$, $V_{CC} = 3.3\text{V}$ to 5.5V , $T_A = -40^\circ\text{C}$ to 85°C , unless otherwise specified.)

Typical values are referred to $T_A = 25^\circ\text{C}$)

Symbol	Parameter	Test Conditions	Min.	Typ.	Max.	Unit
ISUPPLY	V_{CC} Power Supply Current	No Load $V_{CC}=3.3\text{V} \pm 10\%$ $T_A=25^\circ\text{C}$		2.5	5	mA
		No Load $V_{CC}=5\text{V} \pm 10\%$ $T_A=25^\circ\text{C}$		6	10	mA

LOGIC INPUT ELECTRICAL CHARACTERISTICS

($C_1 - C_4 = 0.1\mu\text{F}$, $V_{CC} = 3.3\text{V}$ to 5.5V , $T_A = -40^\circ\text{C}$ to 85°C , unless otherwise specified.)

Typical values are referred to $T_A = 25^\circ\text{C}$)

Symbol	Parameter	Test Conditions	Min.	Typ.	Max.	Unit
V_{TIL}	Input Logic Threshold Low	T-IN (Note 1)			8	V
V_{TIH}	Input Logic Threshold High	$V_{CC} = 3.3\text{V}$	2			V
		$V_{CC} = 5\text{V}$	2.4			V
I_{IL}	Input Leakage Current	T-IN		± 0.01	± 1	μA

Note1: Transmitter input hysteresis is typically 250mV

TRANSMITTER ELECTRICAL CHARACTERISTICS

($C_1 - C_4 = 0.1\mu\text{F}$ tested at $V_{CC} = 3.3\text{V}$ to 5.5V , $T_A = -40^\circ\text{C}$ to 85°C , unless otherwise specified.)

Typical values are referred to $T_A = 25^\circ\text{C}$)

Symbol	Parameter	Test Conditions	Min.	Typ.	Max.	Unit
V_{TOUT}	Output Voltage Swing	All Transmitter outputs are loaded with $3\text{K}\Omega$ to GND	$V_{CC} = 5.0\text{V}$	± 5	± 5.4	V
		$V_{CC} = 3.3\text{V}$	± 3.5	± 4.0		
R_{TOUT}	Transmitter Output Resistance	$V_{CC} = V_+ = V_- = 0\text{V}$	$V_{OUT} = \pm 2\text{V}$	300	10M	Ω
I_{TSC}	Output Short Circuit Current	$V_{CC} = 3.3\text{V}$ to 5V	$V_{OUT} = 0\text{V}$		± 60	mA

RECEIVER ELECTRICAL CHARACTERISTICS

(C1 - C4 = 0.1μF tested at VCC = 3.3V to 5.5V, TA = -40°C to 85°C, unless otherwise specified. Typical values are referred to TA = 25°C)

Symbol	Parameter	Test Conditions	Min.	Typ.	Max.	Unit
VRIN	Receiver Input Voltage Operating Range		-25		25	V
VRIL	RS-232 Input Threshold Low	TA = 25°C VCC = 3.3V	0.6	1.2		V
		TA = 25°C VCC = 5V	0.8	1.5		
VRIH	RS-232 Input Threshold High	TA = 25°C VCC = 3.3V		1.5	2.4	V
		TA = 25°C VCC = 5V		1.8	2.4	
VRIHYS	Input Hysteresis			0.3		V
RRIN	Input Resistance	TA = 25°C	3	5	7	kΩ
VROL	TTL/CMOS Output Voltage Low	IOUT = 1.6mA VCC = 3.3V			0.4	V
		IOUT = 3.2mA VCC = 5.5V				
VROH	TTL/CMOS Output Voltage High	IOUT = -0.5mA VCC = 3.3V	VCC-0.	VCC-0.		V
		IOUT = -1mA VCC = 5.5V	6	1		

TIMING CHARACTERISTICS

(C1 - C4 = 0.1μF, VCC = 3.3V to 5.5V, TA = -40°C to 85°C, unless otherwise specified. Typical values are referred to TA = 25°C)

Symbol	Parameter	Test Conditions		Min.	Typ.	Max.	Unit
D _R	Data Transfer Rate	R _L = 3KΩ	C _{L2} = 1000pF one transmitter switching	V _{CC} =3.3V		120	Kbps
t _{PHLR} t _{PLHR}	Propagation Delay Input to Output	R _{XIN} =R _{XOUT}	C _L = 150pF		4.0	9.7	μs
t _{PHLT} t _{PLHT}	Propagation Delay Input to Output	R _L = 3KΩ	C _L = 2500pF		2.0	5.0	μs
t _{PHLR} - t _{PLHR}	Receiver Propagation Delay Difference				300		ns
t _{PHLT} - t _{PLHT}	Transmitter Propagation Delay Difference				300		ns
SRT	Transition Slew Rate	T _A = 25°C R _L = 3KΩ to 7KΩ V _{CC} = 3.3V measured from +3V to -3V or -3V to +3V C _L = 150pF to 1000pF		3		30	V/μs

APPLICATION CIRCUITS

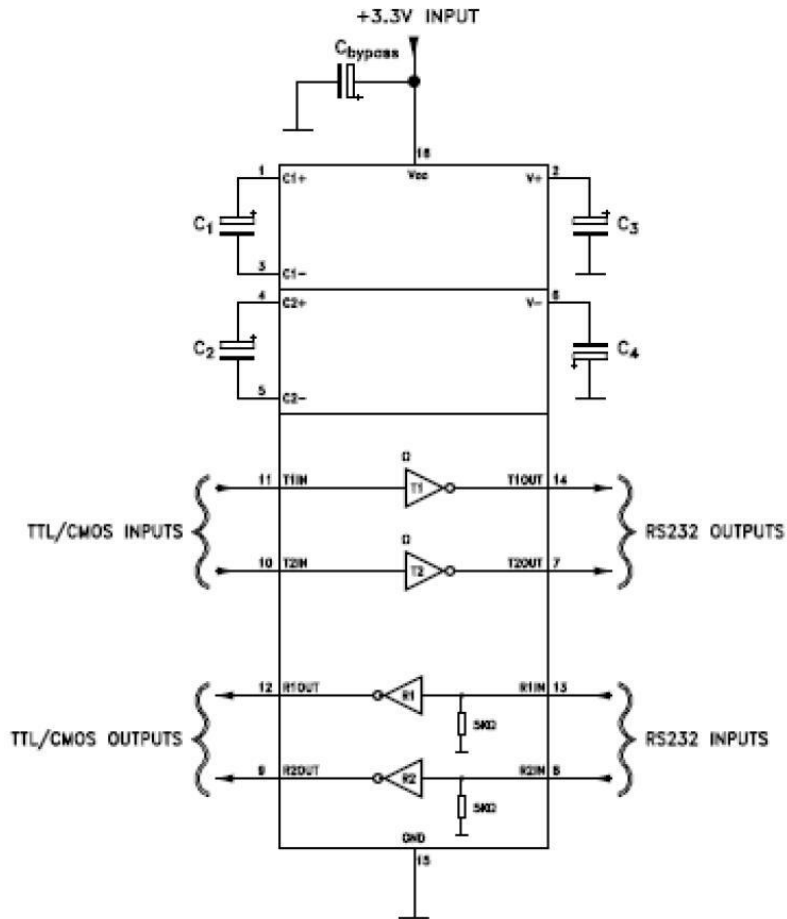

CAPACITANCE VALUE (μF)

V _{CC}	C1	C2	C3	C4	C _{bypass}
3.0 to 5.5	1.0	1.0	1.0	1.0	1.0

TYPICAL OPERATING CHARACTERISTICS

($V_{CC} = +3.3V$, 120kbps data rate, $0.1\mu F$ capacitors, all transmitters loaded with $3k\Omega$, $T_A = +25^\circ C$, unless otherwise noted.)

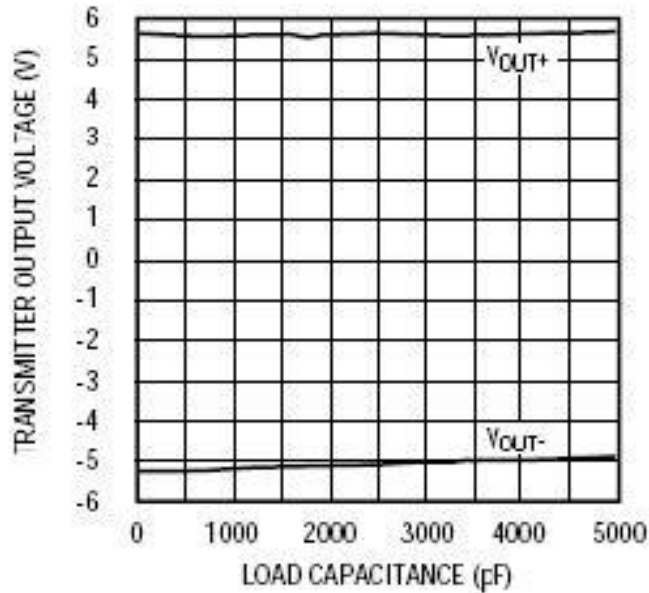

TRANSMITTER OUTPUT VOLTAGE vs. LOAD CAPACITANCE

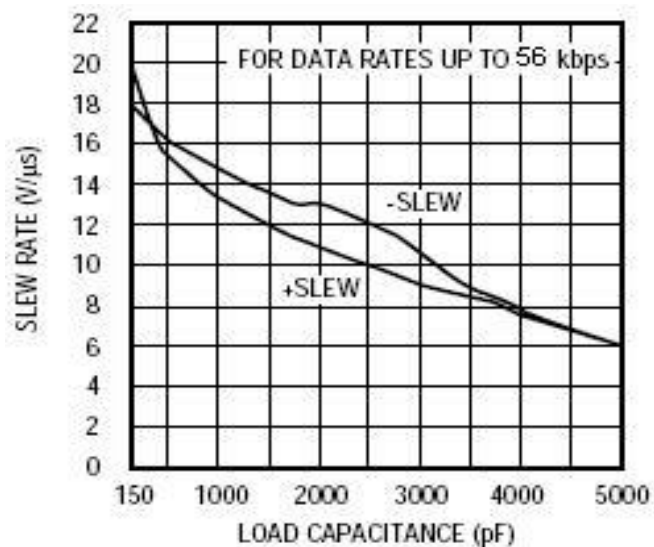

SLEW RATE vs. LOAD CAPACITANCE

ESD PROTECTION

The CBM3232 incorporates ruggedized ESD cells on all driver output and receiver input pins. The ESD structure is for rugged applications and environments sensitive to electro-static discharges and associated transients. The ESD tolerance is at least $\pm 15\text{kV}$ without damage or latch-up.

There are different methods of ESD testing applied:

- a) MIL-STD-883, Method 3015.7
- b) IEC1000-4-2 Air-Discharge

The Human Body Model has been the generally accepted ESD testing method for semiconductors. This method is also specified in MIL-STD- 883, Method 3015.7 for ESD testing. The premise of this ESD test is to simulate the human body's potential to store electro-static energy and discharge it to an integrated circuit. The simulation is performed by using a test model as shown in Figure 1. This method will test the IC's capability to withstand an ESD transient during normal handling such as in manufacturing areas where the IC's tend to be handled frequently.

The IEC-1000-4-2, formerly IEC801-2, is generally used for testing ESD on equipment and systems. For system manufacturers, they must guarantee a certain amount of ESD protection since the system itself is exposed to the outside environment and human presence. The premise with IEC1000-4-2 is that the system is required to withstand an amount of static electricity when ESD is applied to points and surfaces of the equipment that are accessible to personnel during normal usage. The transceiver IC receives most of the ESD current when the ESD source is applied to the connector pins. The test circuit for IEC1000-4-2 is shown on Figure 2. There are two methods within IEC1000-4-2, the Air Discharge method and the Contact Discharge method.

With the Air Discharge Method, an ESD voltage is applied to the equipment under test (EUT) through air. This simulates an electrically charged person ready to connect a cable onto the rear of the system only to find an unpleasant zap just before the person touches the back panel. The high energy potential on the person discharges through an arcing path to the rear panel of the system before he or she even touches the system. This energy, whether discharged directly or through air, is predominantly a function of the discharge current rather than the discharge voltage. Variables with an air discharge such as approach speed of the object carrying the ESD potential to the system and humidity will tend to change the discharge current. For example, the rise time of the discharge current varies with the approach speed.

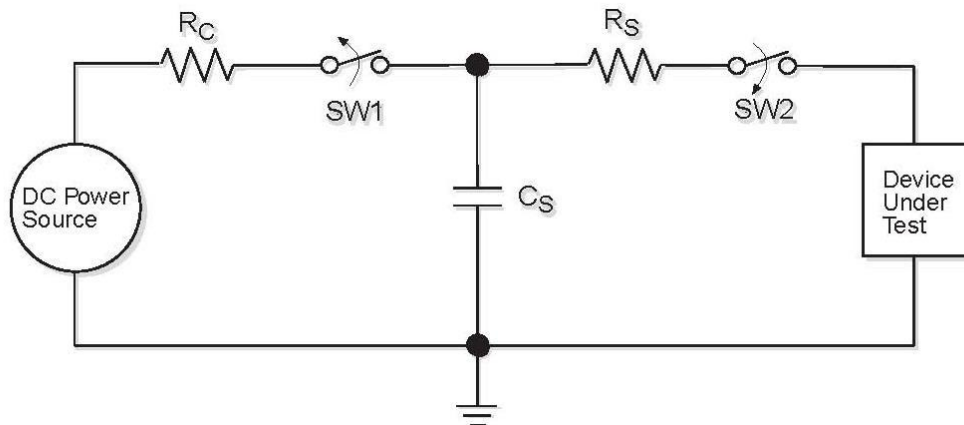

Fig. 1 ESD Test Circuit for Human Body Model

The Contact Discharge Method applies the ESD current directly to the EUT. This method was devised to reduce the unpredictability of the ESD arc. The discharge current rise time is constant since the energy is directly transferred without the air-gap arc. In situations such as hand held systems, the ESD charge can be directly discharged to the equipment from a person already holding the equipment. The current is transferred on to the keypad or the serial port of the equipment directly and then travels through the PCB and finally to the IC.

The circuit models in Figures 1 and 2 represent the typical ESD testing circuits used for these methods. The C_S is initially charged with the DC power supply when the first switch (SW1) is on. Now that the capacitor is charged, the second switch (SW2) is on while SW1 switches off. The voltage stored in the capacitor is then applied through R_S , the current limiting resistor, onto the device under test (DUT). In ESD tests, the SW2 switch is pulsed so that the device under test receives a duration of voltage.

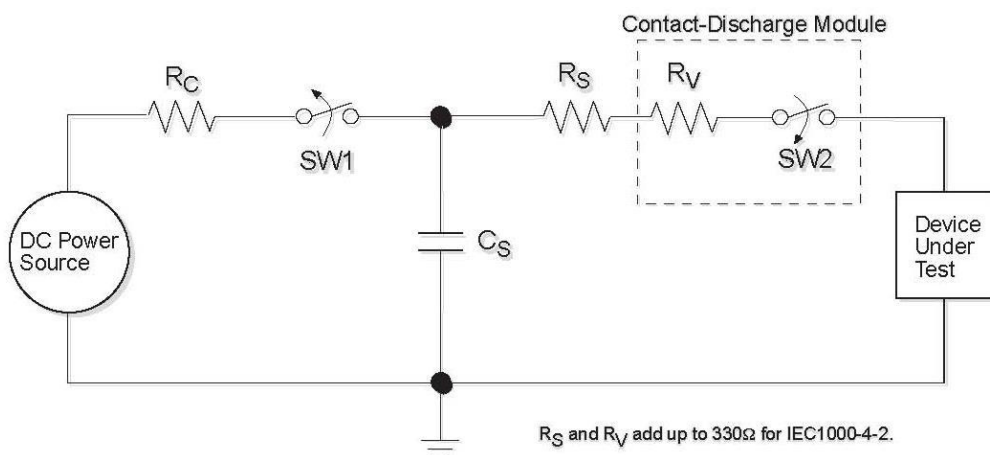

Fig. 2. ESD Test Circuit for IEC1000-4-2

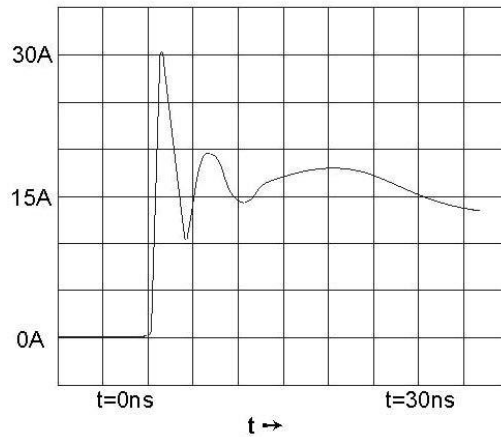
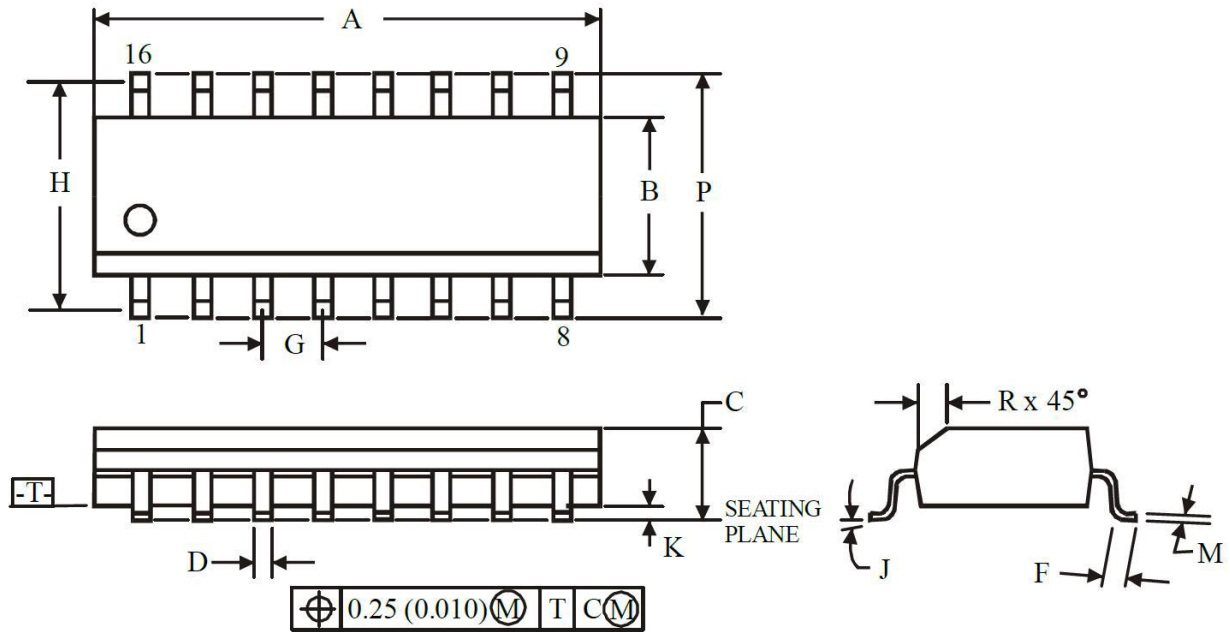

Fig. 3. ESD Test Waveform for IEC1000-4-2

For the Human Body Model, the current limiting resistor (R_S) and the source capacitor (C_S) are $1.5k\Omega$ and $100pF$, respectively. For IEC-1000-4-2, the current limiting resistor (R_S) and the source capacitor (C_S) are 330Ω and $150pF$, respectively. The higher C_S value and lower R_S value in the IEC1000-4-2 model are more stringent than the Human Body Model. The larger storage capacitor injects a higher voltage to the test point when SW2 is switched on. The lower current limiting resistor increases the current charge onto the test point.

Device Pin Tested	IEC1000-4-2	
	Air Discharge	Level
Driver Outputs	$\pm 15kV$	4
Receiver Inputs	$\pm 15kV$	4

PACKAGE



- NOTES:**
- Dimensions A and B do not include mold flash or protrusion.
 - Maximum mold flash or protrusion 0.15 mm (0.006) per side for A; for B - 0.25 mm (0.010) per side.

Symbol	Dimensions ,mm	
	Min	Max
A	9.8	10
B	3.8	4
C	1.35	1.75
D	0.33	0.51
F	0.4	1.27
G	1.27	
H	5.72	
J	0°	8°
K	0.1	0.25
M	0.19	0.25
P	5.8	6.2
R	0.25	0.5

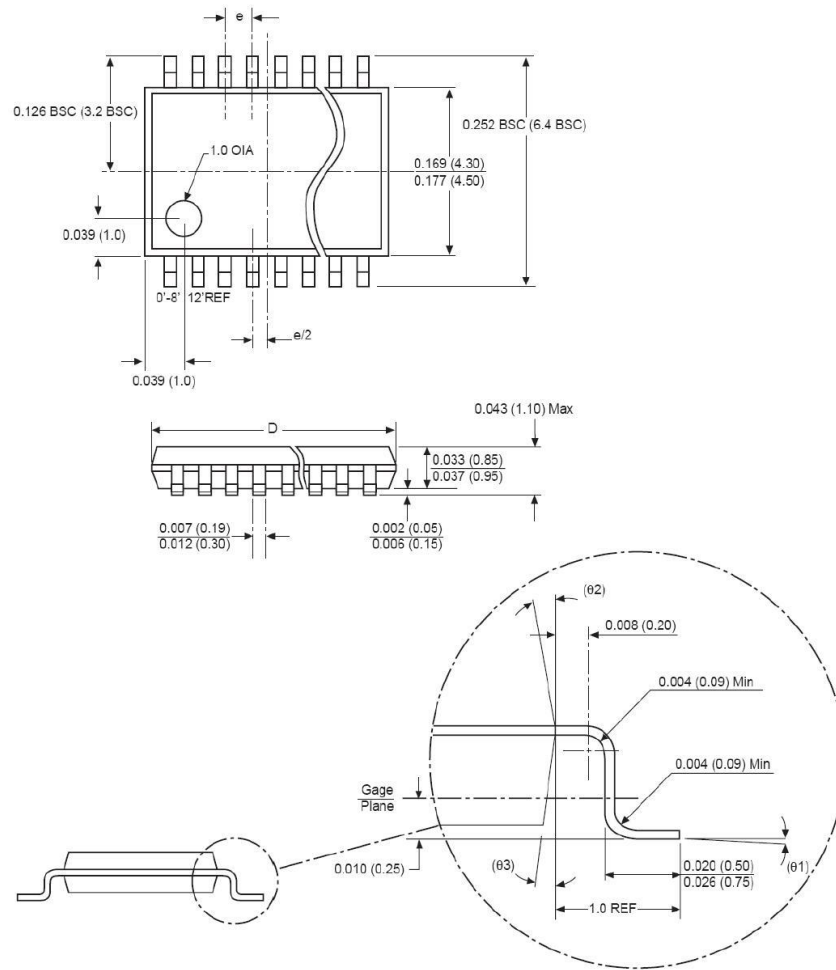

DIMENSIONS		
in inches(mm) Minimum/Maximum		
Symbol	16 Lead	20Lead
D	0.193/0.201 (4.90/5.10)	0.252/0.260 (6.40/6.60)
e	0.026 BSC (0.65BSC)	0.026 BSC (0.65 BSC)

PACKAGE/ORDERING INFORMATION

PRODUCT	ORDERING NUMBER	TEMPRANGE	PACKAGE	PAKEAGE MARKING	TRANSPOT MEDIA,QUANTILY
CBM3232	CBM3232AS16	-40°C~125°C	SOIC-16(SOP16)	CBM3232A	Tape and Reel,2500
	CBM3232ACS16	-0°C~70°C	SOIC-16(SOP16)	CBM3232AC	Tape and Reel,2500
CBM3232	CBM3232ATS16	-40°C~125°C	TSSOP-16	CBM3232AT	Tape and Reel,3000
	CBM3232ATC16	-0°C~75°C	TSSOP-16	CBM3232ATC	Tape and Reel,3000

X-ON Electronics

Largest Supplier of Electrical and Electronic Components

Click to view similar products for [RS-232 Interface IC category](#):

Click to view products by [Corebai Microelectronics manufacturer](#):

Other Similar products are found below :

[MAX232EPE](#) [MAX232ECPE](#) [062191EB](#) [713266CB](#) [MAX3250EAIT](#) [MAX250ESD+T](#) [SP508EEF-L](#) [MAX3218EAP+T](#) [MAX561CAI+T](#)
[MAX3218CAP+T](#) [MAX218EAP+T](#) [MAX3232ECUP+G071](#) [MAX3228AEWV+T](#) [LT1180AISW#TRPBF](#) [MAX3386ECPWR](#)
[TRSF3223ECPWR](#) [ADM202EARWZ-REEL](#) [ICL3232IVZ-T7A](#) [ICL3232IBZ-T](#) [ICL3222EIBZ-T](#) [LMS202EIMX/NOPB](#) [5962-89877012C](#)
[AZ75232GTR-G1](#) [AZ75232GSTR-G1](#) [TRS222IDWR](#) [TRS3223ECDWR](#) [MAX563CPN+](#) [MAX491EESD+](#) [MAX489ESD+](#) [MAX489CPD+](#)
[MAX491ECSD+](#) [MAX487EESA+](#) [MAX3389ECUG](#) [MAX3318EEAP](#) [MAX3244EEUI+](#) [MAX3232ECUE+](#) [MAX3225EETP+](#)
[MAX3223EAPT](#) [MAX3222ECUP+T](#) [MAX3221EUE+T](#) [MAX3221EUE+](#) [MAX3190EEUTT](#) [MAX251CSD+T](#) [MAX248CQH+D](#)
[MAX3245CWI+](#) [MAX3241CUI+T](#) [MAX221EEUE+](#) [MAX3232EEWET](#) [MAX3232EEUET](#) [MAX3232ECPE+](#)