

# DBS100A/DBS150A

DB S 150 A 15

① ② ③ ④ ⑤

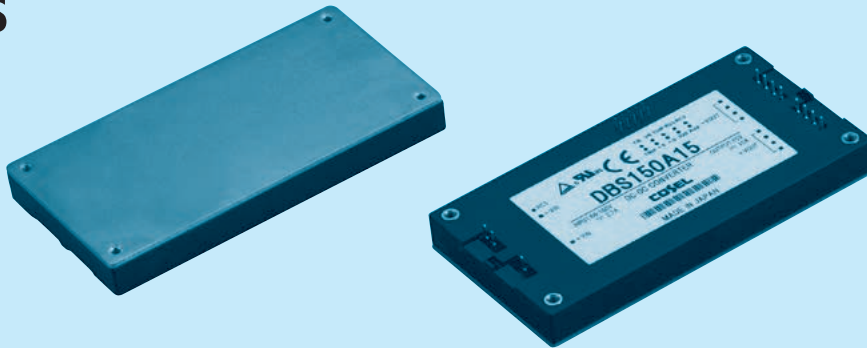

- ① Series name
- ② Single output
- ③ Output wattage
- ④ Input voltage  
A :DC110V input
- ⑤ Output voltage

MODEL	DBS100A05	DBS100A13R8	DBS150A12	DBS150A15	DBS150A24
MAX OUTPUT WATTAGE[W]	100	100.7	150	150	151
DC OUTPUT	5V 20A	13.8V 7.3A	12V 12.5A	15V 10A	24V 6.3A

## SPECIFICATIONS

	MODEL	DBS100A05	DBS100A13R8	DBS150A12	DBS150A15	DBS150A24	
INPUT	VOLTAGE[V]	DC45 - 160		DC66 - 160			
	CURRENT[A]	*1 1.11typ	1.10typ	1.57typ	1.59typ	1.58typ	
	EFFICIENCY[%]	*1 82typ	83typ	87typ	86typ	87typ	
OUTPUT	VOLTAGE[V]	5	13.8	12	15	24	
	CURRENT[A]	20	7.3	12.5	10	6.3	
	LINE REGULATION[mV]	20max	60max	40max	60max	95max	
	LOAD REGULATION[mV]	40max	150max	100max	150max	190max	
	RIPPLE[mVp-p]	0 to +85°C *2	80max	120max	120max	120max	120max
		-20 - 0°C *2	140max	160max	160max	160max	160max
	RIPPLE NOISE[mVp-p]	0 to +85°C *2	100max	150max	150max	150max	150max
		-20 - 0°C *2	150max	180max	180max	180max	180max
	TEMPERATURE REGULATION[mV]	0 to +65°C	50max	180max	120max	180max	280max
		-20 to +85°C	85max	310max	200max	310max	480max
DRIFT[mV]	*3 20max	60max	40max	60max	90max		
START-UP TIME[ms]	200max (DCIN 110V, Io=100%)						
OUTPUT VOLTAGE ADJUSTMENT RANGE	Fixed (TRM pin open), 60 - 110% adjustable by external VR or external voltage						
OUTPUT VOLTAGE SETTING[V]	4.90 - 5.20	13.25 - 14.35	11.60 - 12.60	14.40 - 15.60	23.04 - 24.96		
PROTECTION CIRCUIT AND OTHERS	OVERCURRENT PROTECTION	Works over 105% of rating and recovers automatically					
	OVERVOLTAGE PROTECTION	5.75 - 7.00V	15.87 - 19.32V	13.80 - 16.80V	17.25 - 21.00V	27.60 - 33.60V	
	REMOTE SENSING	Provided					
	REMOTE ON/OFF	Provided (On both side of input and output)					
ISOLATION	INPUT-OUTPUT	AC3,000V 1minute, Cutoff current = 10mA, DC500V 50MΩ min (20±15°C)					
	INPUT-FG	AC2,000V 1minute, Cutoff current = 10mA, DC500V 50MΩ min (20±15°C)					
	OUTPUT-FG	AC500V 1minute, Cutoff current = 100mA, DC500V 50MΩ min (20±15°C)					
	OUTPUT-RC2.RC3	AC100V 1minute, Cutoff current = 100mA, DC100V 10MΩ min (20±15°C)					
ENVIRONMENT	OPERATING TEMP.HUMID.AND ALTTITUDE *4	-20 to +85°C (On aluminum base plate), 20 - 95%RH (Non condensing) (Refer to DERATING CURVE), 3,000m (10,000feet) max					
	STORAGE TEMP.HUMID.AND ALTTITUDE	-40 to +85°C, 20 - 95%RH (Non condensing), 9,000m (30,000feet) max					
	VIBRATION	10 - 55Hz, 49.0m/s <sup>2</sup> (5G), 3minutes period, 60minutes each along X, Y and Z axis					
	IMPACT	196.1m/s <sup>2</sup> (20G), 11ms once each along X, Y and Z axis					
SAFETY	AGENCY APPROVALS	UL60950-1, C-UL, EN60950-1					
OTHERS	CASE SIZE/WEIGHT	61 × 12.7 × 116.8mm [2.4 × 0.5 × 4.6 inches] (W×H×D) / 150g max					
	COOLING METHOD	Conduction cooling (e.g. heat radiation from the aluminum base plate to the attached heat sink)					

\*1 At rated input(DC110V) and rated load.

\*2 Ripple and ripple noise is measured by using measuring board with the recommended capacitor Co & the film capacitor 0.1 μF. Measured by 20MHz oscilloscope or Ripple-Noise meter (Equivalent to KEISOKU-GIKEN:RM101). Refer to the manual.

\*3 Drift is the change in DC output for an eight hour period after a half-hour warm-up at 25°C, with the input voltage held constant at the rated input/output.

\*4 Please consult us in regard to use from -40°C.

## External view

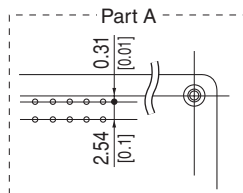
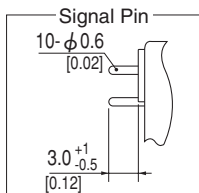
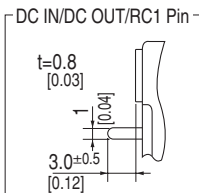
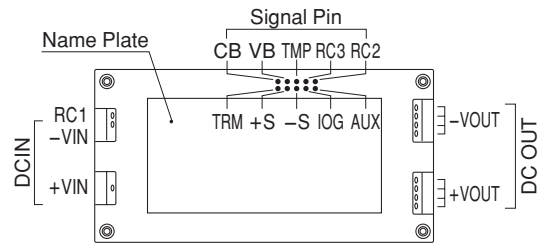
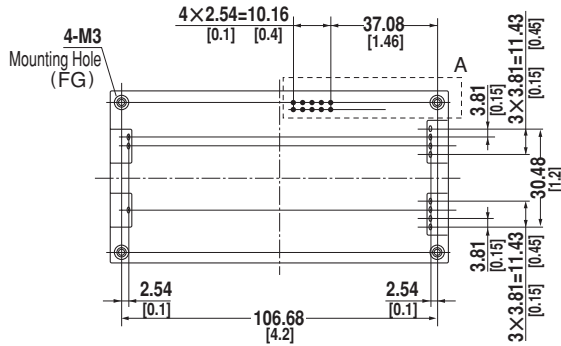
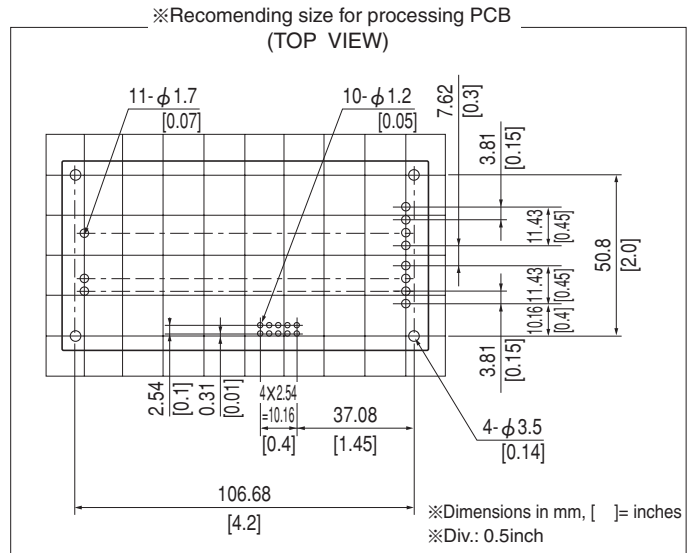
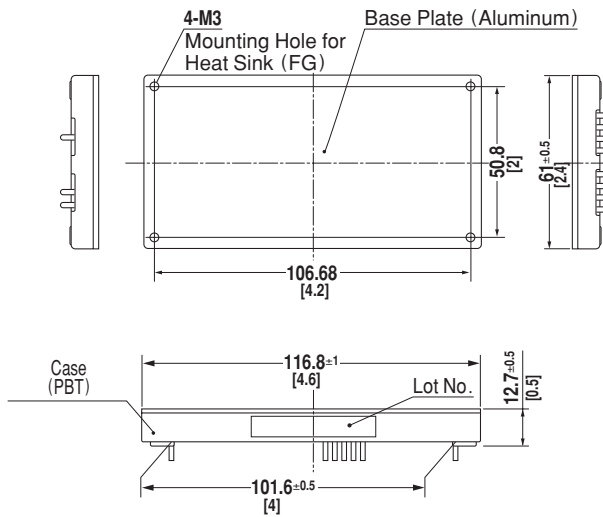

- ※Weight: 150g max
- ※Tolerance: ±0.3 [±0.012]
- ※Base Plate: Aluminum
- ※Dimensions in mm, [ ] = inches
- ※Mounting hole screwing torque: 0.49N·m(5.0kgf·cm)

# DBS200B

DB S 200 B 03

① ② ③ ④ ⑤

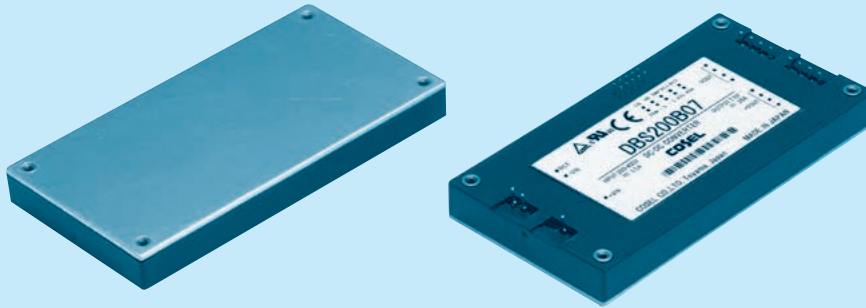

- ① Series name
- ② Single output
- ③ Output wattage
- ④ Input voltage  
B : DC200 - 400V
- ⑤ Output voltage

MODEL	DBS200B03	DBS200B05	DBS200B07	DBS200B12
MAX OUTPUT WATTAGE[W]	165	200	210	240
DC OUTPUT	3.3V 50A	5V 40A	7.5V 28A	12V 20A

## SPECIFICATIONS

	MODEL	DBS200B03	DBS200B05	DBS200B07	DBS200B12	
INPUT	VOLTAGE[V]	DC200 - 400				
	CURRENT[A]	*1 0.75typ	0.86typ	0.87typ	0.99typ	
	EFFICIENCY[%]	*1 79typ	83typ	86typ	87typ	
OUTPUT	VOLTAGE[V]	3.3	5	7.5	12	
	CURRENT[A]	50	40	28	20	
	LINE REGULATION[mV]	16max	20max	30max	40max	
	LOAD REGULATION[mV]	30max	40max	60max	100max	
	RIPPLE[mVp-p]	0 to +85°C *2	80max	80max	100max	120max
		-20 - 0°C *2	140max	140max	150max	160max
	RIPPLE NOISE[mVp-p]	0 to +85°C *2	100max	100max	140max	150max
		-20 - 0°C *2	150max	150max	160max	180max
	TEMPERATURE REGULATION[mV]	0 to +65°C	35max	50max	75max	120max
		-20 to +85°C	60max	85max	130max	200max
DRIFT[mV]	*3	16max	20max	30max	40max	
START-UP TIME[ms]	200max (DCIN 280V, Io=100%)					
OUTPUT VOLTAGE ADJUSTMENT RANGE	Fixed (TRM pin open), 60 - 110% adjustable by external VR or external voltage					
OUTPUT VOLTAGE SETTING[V]	3.25 - 3.45	4.90 - 5.20	7.25 - 7.85	11.60 - 12.60		
PROTECTION CIRCUIT AND OTHERS	OVERCURRENT PROTECTION	Works over 105% of rating and recovers automatically				
	OVERVOLTAGE PROTECTION	4.00 - 5.50V	5.75 - 7.00V	8.60 - 10.50V	13.80 - 16.80V	
	REMOTE SENSING	Provided				
	REMOTE ON/OFF	Provided (On both side of input and output)				
ISOLATION	INPUT-OUTPUT	AC3,000V 1minute, Cutoff current = 10mA, DC500V 50MΩ min (20±15°C)				
	INPUT-FG	AC2,000V 1minute, Cutoff current = 10mA, DC500V 50MΩ min (20±15°C)				
	OUTPUT-FG	AC500V 1minute, Cutoff current = 100mA, DC500V 50MΩ min (20±15°C)				
	OUTPUT-RC2.RC3	AC100V 1minute, Cutoff current = 100mA, DC100V 10MΩ min (20±15°C)				
ENVIRONMENT	OPERATING TEMP.HUMID.AND ALTITUDE *4	-20 to +85°C (On aluminum base plate), 20 - 95%RH (Non condensing) (Refer to DERATING CURVE), 3,000m (10,000feet) max				
	STORAGE TEMP.HUMID.AND ALTITUDE	-40 to +85°C, 20 - 95%RH (Non condensing), 9,000m (30,000feet) max				
	VIBRATION	10 - 55Hz, 49.0m/s <sup>2</sup> (5G), 3minutes period, 60minutes each along X, Y and Z axis				
	IMPACT	196.1m/s <sup>2</sup> (20G), 11ms once each along X, Y and Z axis				
SAFETY	AGENCY APPROVALS	UL60950-1, C-UL, EN60950-1, EN50178 Complies with DEN-AN and IEC60950-1				
OTHERS	CASE SIZE/WEIGHT	61 × 12.7 × 116.8mm [2.4 × 0.5 × 4.6 inches] (W×H×D) / 150g max				
	COOLING METHOD	Conduction cooling (e.g. heat radiation from the aluminum base plate to the attached heat sink)				

\*1 At rated input(DC280V) and rated load.

\*2 Ripple and ripple noise is measured by using measuring board with the recommended capacitor Co & the film capacitor 0.1 μF. Measured by 20MHz oscilloscope or Ripple-Noise meter (Equivalent to KEISOKU-GIKEN:RM101). Refer to the manual.

\*3 Drift is the change in DC output for an eight hour period after a half-hour warm-up at 25°C, with the input voltage held constant at the rated input/output.

\*4 Please consult us in regard to use from -40°C.

## External view

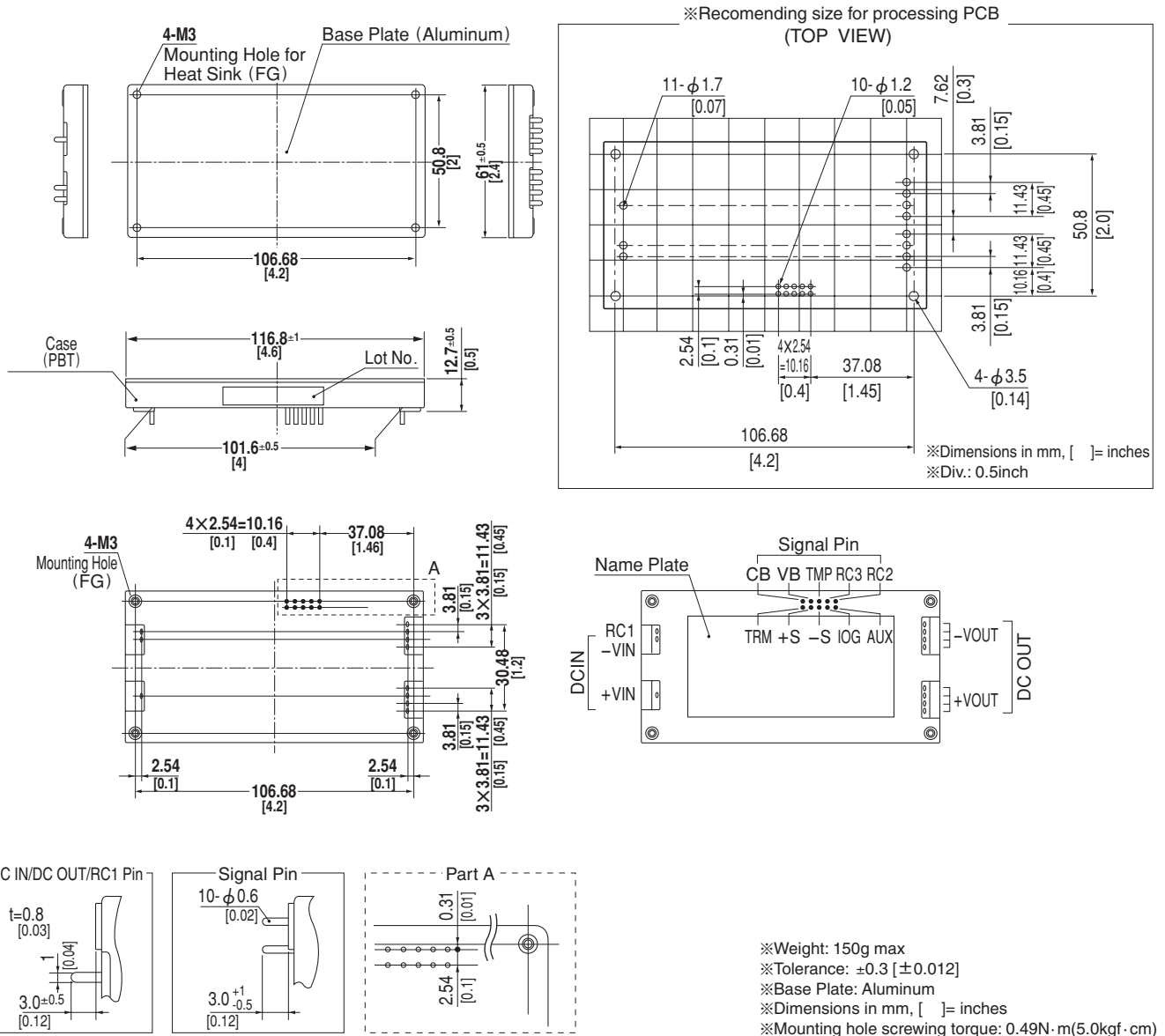

## Performance data

### INPUT CURRENT CHARACTERISTICS (DBS200B12)

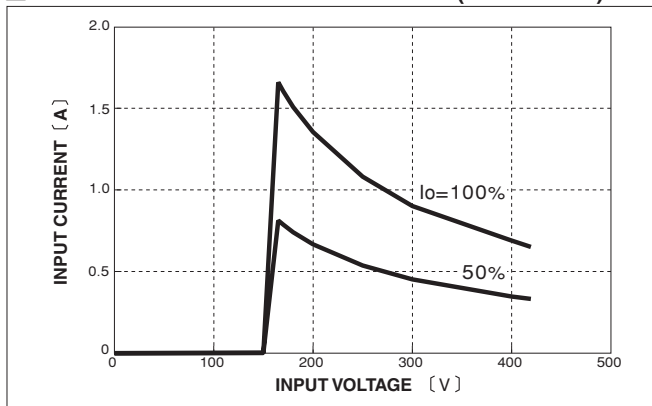

### EFFICIENCY CHARACTERISTICS

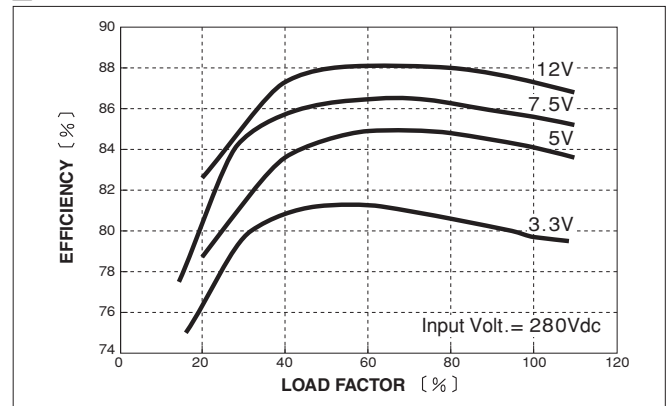

# DBS400B

DB S 400 B 03

① ② ③ ④ ⑤

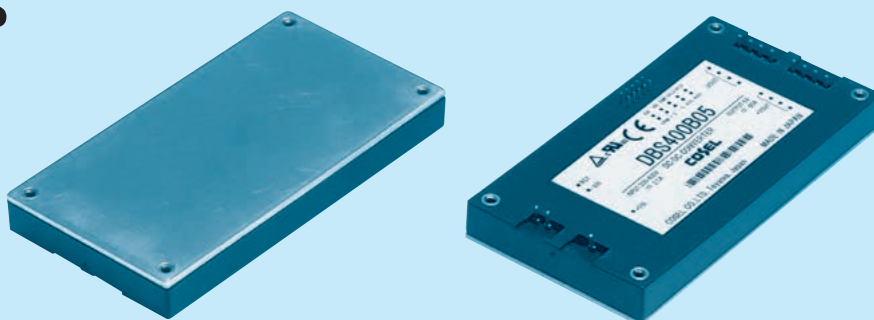

- ① Series name
- ② Single output
- ③ Output wattage
- ④ Input voltage  
B : DC200 - 400V
- ⑤ Output voltage

MODEL	DBS400B03	DBS400B05	DBS400B07	DBS400B12	DBS400B15	DBS400B18	DBS400B24	DBS400B28
MAX OUTPUT WATTAGE[W]	264	400	405	408	405	396	408	406
DC OUTPUT	3.3V 80A	5V 80A	7.5V 54A	12V 34A	15V 27A	18V 22A	24V 17A	28V 14.5A

## SPECIFICATIONS

	MODEL	DBS400B03	DBS400B05	DBS400B07	DBS400B12	DBS400B15	DBS400B18	DBS400B24	DBS400B28	
INPUT	VOLTAGE[V]	DC200 - 400								
	CURRENT[A]	*1 1.19typ	1.72typ	1.68typ	1.67typ	1.66typ	1.61typ	1.67typ	1.63typ	
	EFFICIENCY[%]	*1 79typ	83typ	86typ	87typ	87typ	89typ	87typ	88typ	
OUTPUT	VOLTAGE[V]	3.3	5	7.5	12	15	18	24	28	
	CURRENT[A]	80	80	54	34	27	22	17	14.5	
	LINE REGULATION[mV]	16max	20max	30max	40max	60max	60max	95max	95max	
	LOAD REGULATION[mV]	30max	40max	60max	100max	150max	150max	190max	190max	
	RIPPLE[mVp-p]	0 to +85°C *2	80max	80max	100max	120max	120max	120max	120max	120max
		-20 - 0°C *2	140max	140max	150max	160max	160max	160max	160max	160max
	RIPPLE NOISE[mVp-p]	0 to +85°C *2	100max	100max	140max	150max	150max	150max	150max	150max
		-20 - 0°C *2	150max	150max	160max	180max	180max	180max	180max	180max
	TEMPERATURE REGULATION[mV]	0 to +65°C	35max	50max	75max	120max	180max	180max	280max	280max
		-20 to +85°C	60max	85max	130max	200max	310max	310max	480max	480max
DRIFT[mV]	*3	16max	20max	30max	40max	60max	60max	90max	90max	
START-UP TIME[ms]	200max (DCIN 280V, Io=100%)									
OUTPUT VOLTAGE ADJUSTMENT RANGE	Fixed (TRM pin open), 60 - 110% adjustable by external VR or external voltage									
OUTPUT VOLTAGE SETTING[V]	3.25 - 3.45	4.90 - 5.20	7.25 - 7.85	11.60 - 12.60	14.40 - 15.60	17.28 - 18.72	23.04 - 24.96	26.88 - 29.12		
PROTECTION CIRCUIT AND OTHERS	OVERCURRENT PROTECTION	Works over 105% of rating and recovers automatically								
	OVERVOLTAGE PROTECTION	4.00 - 5.50V	5.75 - 7.00V	8.60 - 10.50V	13.80 - 16.80V	17.25 - 21.00V	20.70 - 25.20V	27.60 - 33.60V	32.20 - 39.20V	
	REMOTE SENSING	Provided								
	REMOTE ON/OFF	Provided (On both side of input and output)								
ISOLATION	INPUT-OUTPUT	AC3,000V 1minute, Cutoff current = 10mA, DC500V 50MΩ min (20±15°C)								
	INPUT-FG	AC2,000V 1minute, Cutoff current = 10mA, DC500V 50MΩ min (20±15°C)								
	OUTPUT-FG	AC500V 1minute, Cutoff current = 100mA, DC500V 50MΩ min (20±15°C)								
	OUTPUT-RC2.RC3	AC100V 1minute, Cutoff current = 100mA, DC100V 10MΩ min (20±15°C)								
ENVIRONMENT	OPERATING TEMP.HUMID.AND ALTITUDE *4	-20 to +85°C (On aluminum base plate), 20 - 95%RH (Non condensing) (Refer to DERATING CURVE), 3,000m (10,000feet) max								
	STORAGE TEMP.HUMID.AND ALTITUDE	-40 to +85°C, 20 - 95%RH (Non condensing), 9,000m (30,000feet) max								
	VIBRATION	10 - 55Hz, 49.0m/s <sup>2</sup> (5G), 3minutes period, 60minutes each along X, Y and Z axis								
	IMPACT	196.1m/s <sup>2</sup> (20G), 11ms once each along X, Y and Z axis								
SAFETY	AGENCY APPROVALS	UL60950-1, C-UL, EN60950-1, EN50178 Complies with DEN-AN and IEC60950-1								
OTHERS	CASE SIZE/WEIGHT	61 × 12.7 × 116.8mm [2.4 × 0.5 × 4.6 inches] (W×H×D) / 180g max								
	COOLING METHOD	Conduction cooling (e.g. heat radiation from the aluminum base plate to the attached heat sink)								

\*1 At rated input(DC280V) and rated load.

\*2 Ripple and ripple noise is measured by using measuring board with the recommended capacitor Co & the film capacitor 0.1 μF. Measured by 20MHz oscilloscope or Ripple-Noise meter (Equivalent to KEISOKU-GIKEN:RM101). Refer to the manual.

\*3 Drift is the change in DC output for an eight hour period after a half-hour warm-up at 25°C, with the input voltage held constant at the rated input/output.

\*4 Please consult us in regard to use from -40°C.

## External view

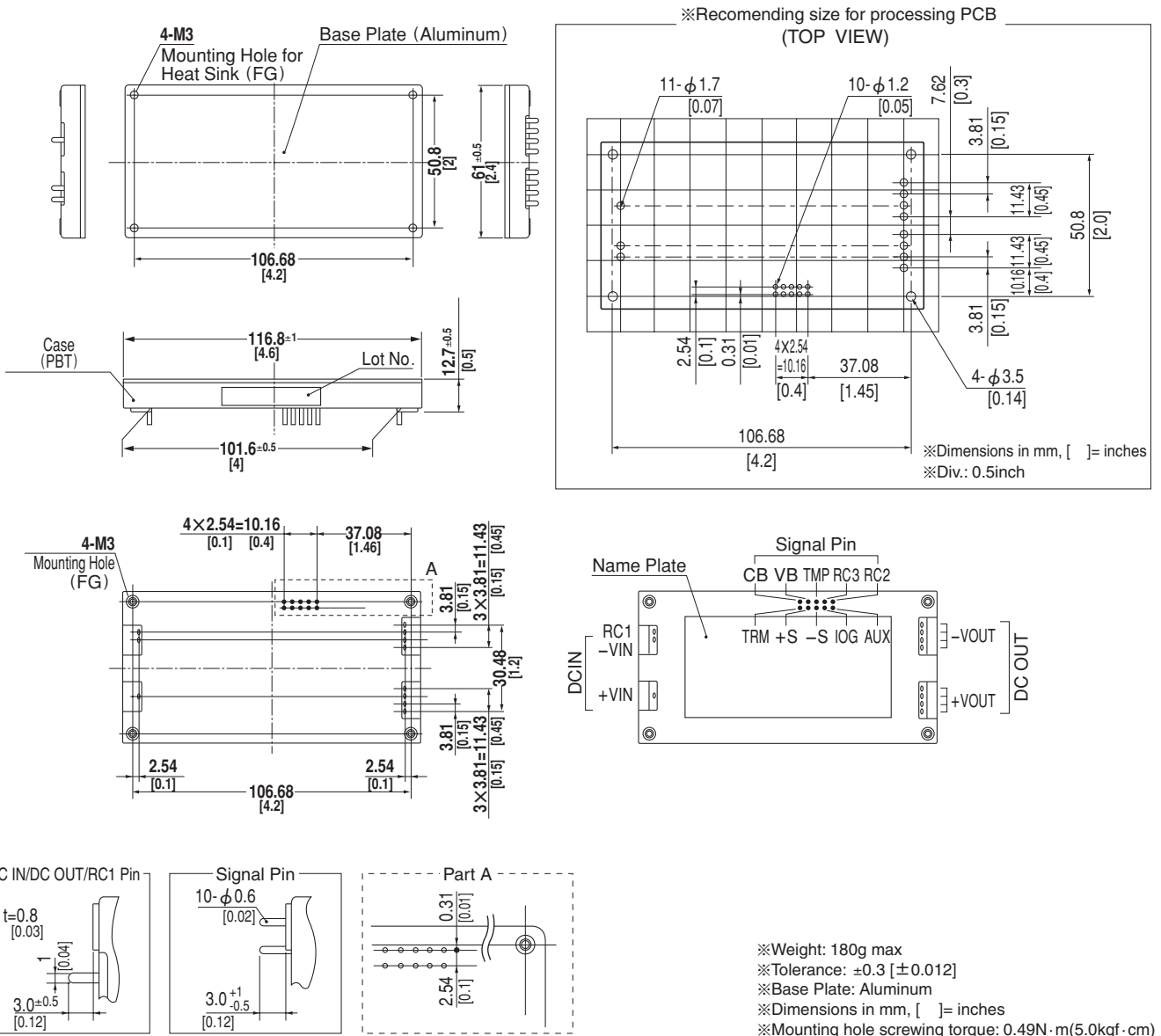

## Performance data

### INPUT CURRENT CHARACTERISTICS (DBS400B12)

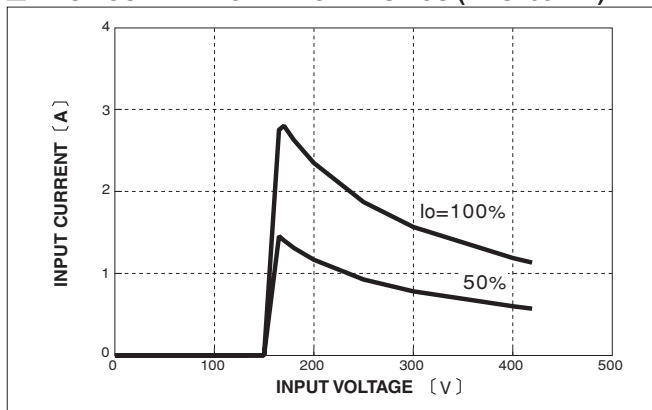

### EFFICIENCY CHARACTERISTICS

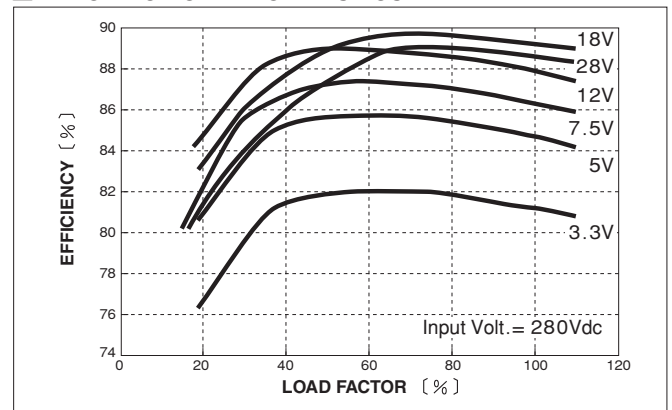

# DBS700B

DB S 700 B 28 -□

① ② ③ ④ ⑤ ⑥

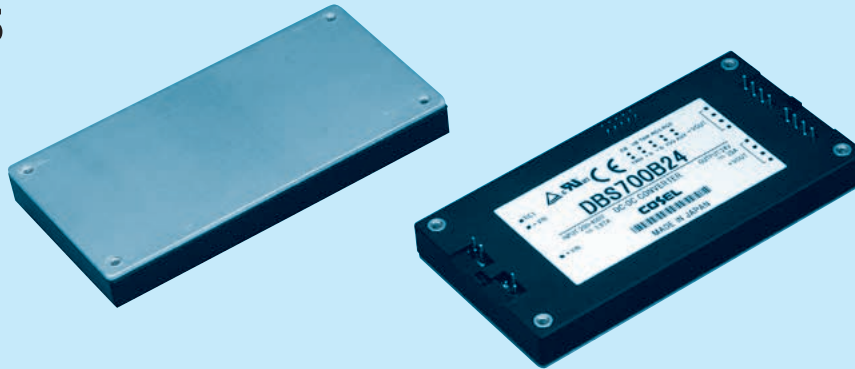
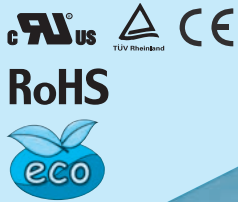

- ① Series name
- ② Single output
- ③ Output wattage
- ④ Input voltage  
B : DC200 - 400V
- ⑤ Output voltage
- ⑥ Optional  
T : with Mounting hole  
(φ 3.4 thru)

MODEL	DBS700B12	DBS700B24	DBS700B28	DBS700B36	DBS700B48
MAX OUTPUT WATTAGE[W]	696	696	700	702	696
DC OUTPUT	12V 58A	24V 29A	28V 25A	36V 19.5A	48V 14.5A

## SPECIFICATIONS

	MODEL	DBS700B12	DBS700B24	DBS700B28	DBS700B36	DBS700B48	
INPUT	VOLTAGE[V]	DC200 - 400					
	CURRENT[A]	*1 2.76typ	2.76typ	2.76typ	2.76typ	2.73typ	
	EFFICIENCY[%]	*1 90.0typ	90.0typ	90.5typ	90.0typ	91.0typ	
OUTPUT	VOLTAGE[V]	12	24	28	36	48	
	CURRENT[A]	58	29	25	19.5	14.5	
	LINE REGULATION[mV]	40max	95max	95max	95max	120max	
	LOAD REGULATION[mV]	100max	190max	190max	200max	240max	
	RIPPLE[mVp-p]	0 to +100°C*2	120max	120max	120max	150max	200max
		-40 to 0°C*2	160max	160max	160max	200max	250max
	RIPPLE NOISE[mVp-p]	0 to +100°C*2	150max	150max	150max	200max	250max
		-40 to 0°C*2	180max	180max	180max	240max	400max
	TEMPERATURE REGULATION[mV]	0 to +65°C	120max	280max	280max	360max	480max
		-40 to +100°C	200max	480max	480max	680max	960max
DRIFT[mV]	*3 40max	90max	90max	120max	180max		
START-UP TIME[ms]	200max (DCIN 280V, Io=100%)						
OUTPUT VOLTAGE ADJUSTMENT RANGE *4	Fixed (TRM pin open), 60 - 110% adjustable by external VR or external voltage						
OUTPUT VOLTAGE SETTING[V]	11.64 - 12.36	23.28 - 24.72	27.16 - 28.84	34.92 - 37.08	46.56 - 49.44		
PROTECTION CIRCUIT AND OTHERS	OVERCURRENT PROTECTION	Works over 105% of rating and recovers automatically					
	OVERVOLTAGE PROTECTION	14.40 - 16.80V	27.60 - 33.60V	32.20 - 39.20V	41.40 - 50.40V	55.20 - 63.00V	
	REMOTE SENSING	Provided					
	REMOTE ON/OFF	Provided (On both side of input and output)					
ISOLATION	INPUT-OUTPUT	AC3,000V 1minute, Cutoff current = 10mA, DC500V 50MΩ min (20±15°C)					
	INPUT-FG	AC2,000V 1minute, Cutoff current = 10mA, DC500V 50MΩ min (20±15°C)					
	OUTPUT-FG	AC500V 1minute, Cutoff current = 100mA, DC500V 50MΩ min (20±15°C)					
	OUTPUT-RC2,RC3	AC100V 1minute, Cutoff current = 100mA, DC100V 10MΩ min (20±15°C)					
ENVIRONMENT	OPERATING TEMP.,HUMID.AND ALTITUDE	-40 to +100°C (On aluminum base plate), 20 - 95%RH (Non condensing) (Refer to DERATING CURVE), 3,000m (10,000feet) max					
	STORAGE TEMP.,HUMID.AND ALTITUDE	-40 to +100°C, 20 - 95%RH (Non condensing), 9,000m (30,000feet) max					
	VIBRATION	10 - 55Hz, 49.0m/s <sup>2</sup> , 3minutes period, 60minutes each along X, Y and Z axis					
	IMPACT	196.1m/s <sup>2</sup> , 11ms once each along X, Y and Z axis					
SAFETY	AGENCY APPROVALS	UL60950-1, C-UL, EN60950-1, EN50178					
OTHERS	CASE SIZE/WEIGHT	61 × 12.7 × 116.8mm [2.4 × 0.5 × 4.6 inches] (W×H×D) / 180g max					
	COOLING METHOD	Conduction cooling (e.g. heat radiation from the aluminum base plate to the attached heat sink)					

\*1 At rated input(DC280V) and rated load.

\*2 Ripple and ripple noise is measured by using measuring board with the recommended capacitor Co & the film capacitor 0.1 μF. Refer to the manual.

\*3 Drift is the change in DC output for an eight hour period after a half-hour warm-up at 25°C, with the input voltage held constant at the rated input/output.

\*4 Refer to the manual for the input range.

## External view

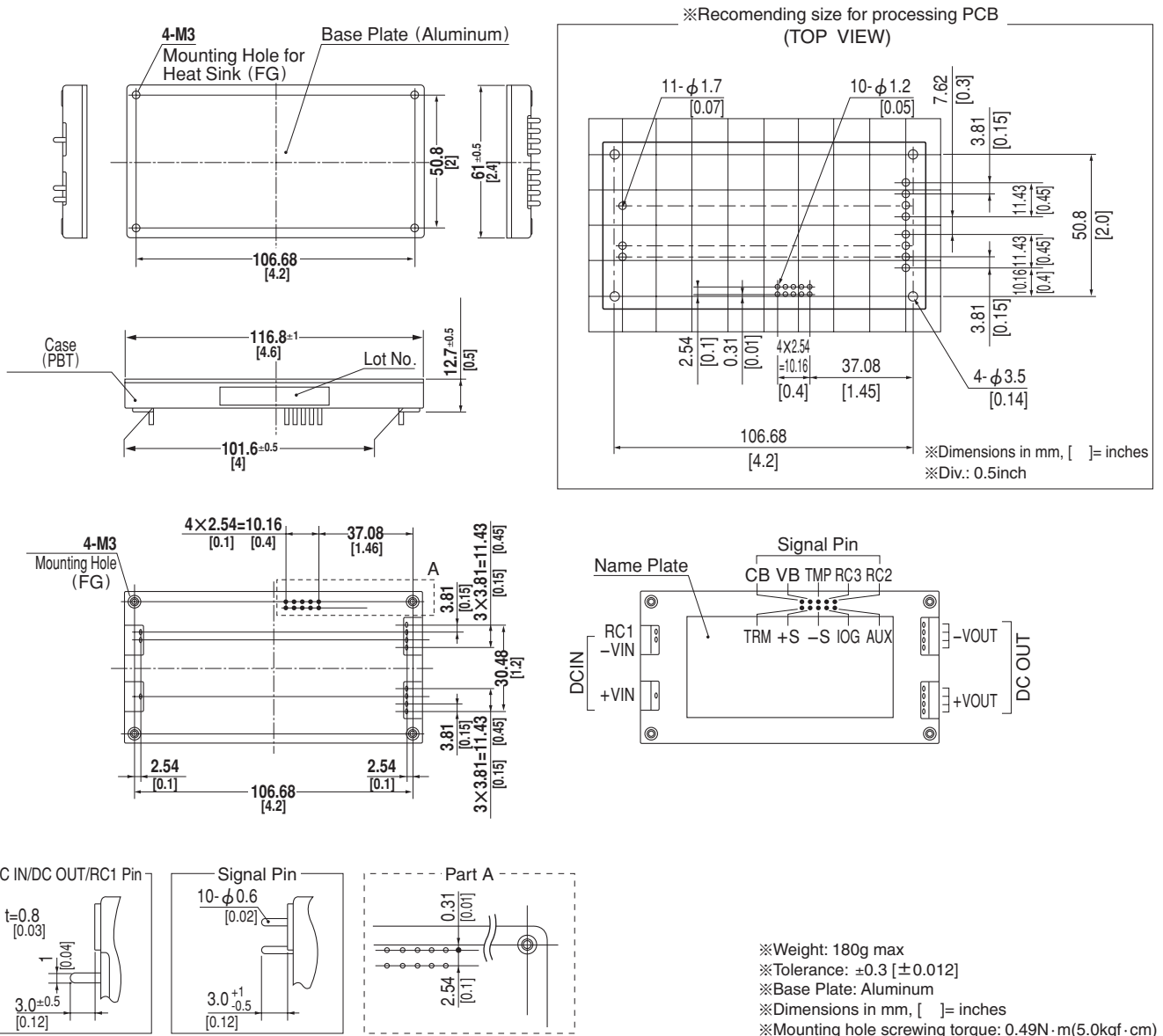

## Performance data

### INPUT CURRENT CHARACTERISTICS (DBS700B28)

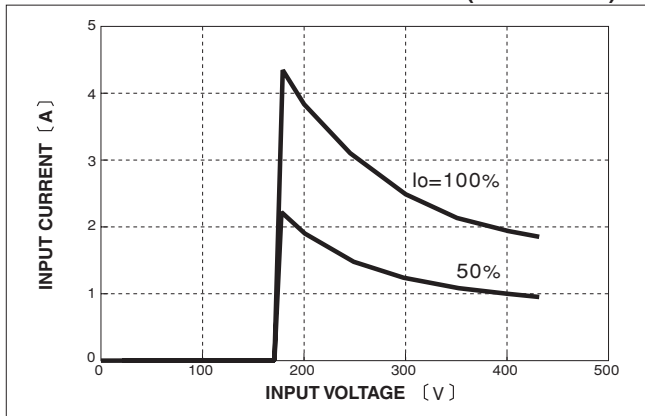

### EFFICIENCY CHARACTERISTICS (DBS700B28)

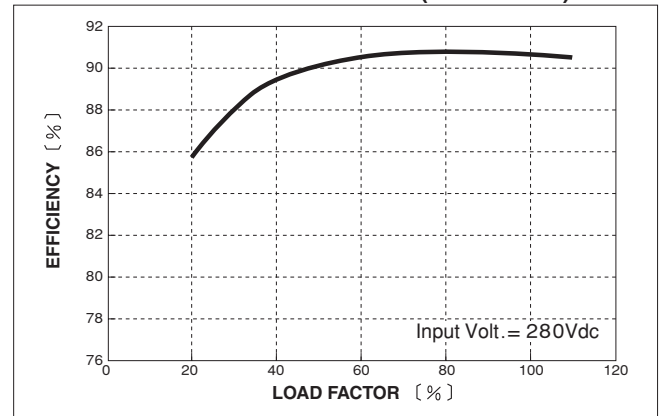



## X-ON Electronics

Largest Supplier of Electrical and Electronic Components

*Click to view similar products for [Isolated DC/DC Converters](#) category:*

*Click to view products by [Cosel](#) manufacturer:*

Other Similar products are found below :

[ESM6D044440C05AAQ](#) [FMD15.24G](#) [PSL486-7LR](#) [PSR152.5-7IR](#) [Q48T30020-NBB0](#) [AVO240-48S12B-6L](#) [AVO250-48S28B-6L](#) [NAN-0505](#) [HW-L16D](#) [JAHW100Y1](#) [217-1617-001](#) [22827](#) [SPB05C-12](#) [SQ24S15033-PS0S](#) [18952](#) [19-130041](#) [CE-1003](#) [CE-1004](#) [GQ2541-7R](#) [PSE1000DCDC-12V](#) [RDS180245](#) [MAU228](#) [419-2065-201](#) [449-2075-101](#) [TME 0303S](#) [TME 0505S](#) [TME 1205S](#) [TME 1212S](#) [TME 2405S](#) [TME 2412S](#) [J80-0041NL](#) [V300C24C150BG](#) [419-2062-200](#) [419-2063-401](#) [419-2067-101](#) [419-2067-501](#) [419-2068-001](#) [DCG40-5G](#) [DFC15U48D15](#) [449-2067-000](#) [XGS-0512](#) [XGS-1205](#) [XGS-1212](#) [XGS-2412](#) [XGS-2415](#) [XKS-1215](#) [033456](#) [NCT1000N040R050B](#) [SPB05B-15](#) [SPB05C-15](#)