

LEA50F

LEA 50 F -5 -□

① ② ③ ④ ⑤

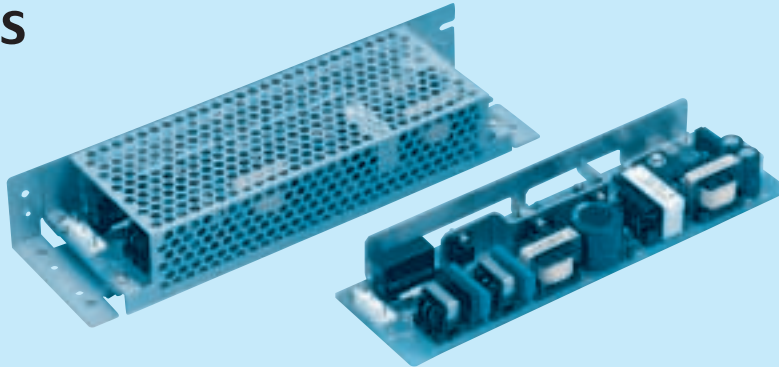

Recommended EMI/EMC Filter
NAC-06-472



High voltage pulse noise type : NAP series
Low leakage current type : NAM series
*The EMI/EMC Filter is recommended to connect with several devices.

- ① Series name
- ② Output wattage
- ③ Universal input
- ④ Output voltage
- ⑤ Optional *6
- C : with Coating
- G : Low leakage current
- J2 : Mini terminal block
- R : with Remote ON/OFF
- S : with Chassis
- SN : with Chassis & cover
- Y : with Potentiometer

MODEL	LEA50F-3R3-Y	LEA50F-5	LEA50F-9	LEA50F-12	LEA50F-15	LEA50F-18	LEA50F-24	LEA50F-24-H	LEA50F-30	LEA50F-48
MAX OUTPUT WATTAGE[W]	33	50	50.4	51.6	52.5	50.4	50.4	50.4	51	52.8
DC OUTPUT	*5 3.3V 10A	5V 10A	9V 5.6A	12V 4.3A	15V 3.5A	18V 2.8A	24V 2.1A	24V 2.1(2.6)A	30V 1.7A	48V 1.1A

SPECIFICATIONS

	MODEL	LEA50F-3R3-Y	LEA50F-5	LEA50F-9	LEA50F-12	LEA50F-15	LEA50F-18	LEA50F-24	LEA50F-24-H	LEA50F-30	LEA50F-48	
INPUT	VOLTAGE[V]	AC85 - 264 1φ or DC120 - 370										
	CURRENT[A]	ACIN 100V	0.6	0.7typ								
		ACIN 200V	0.3	0.35typ								
	FREQUENCY[Hz]	50/60 (47 - 63) or DC										
	EFFICIENCY[%]	ACIN 100V	70typ	75typ	78typ	78typ	79typ	80typ	81typ	81typ	82typ	83typ
		ACIN 200V	71typ	77typ	80typ	80typ	81typ	82typ	83typ	83typ	84typ	85typ
	POWER FACTOR	ACIN 100V	0.98typ	0.99typ								
ACIN 200V		0.91typ	0.93typ									
INRUSH CURRENT[A]	ACIN 100V	15typ (Io=100%) (At cold start) (Ta=25°C)										
	ACIN 200V	30typ (Io=100%) (At cold start) (Ta=25°C)										
LEAKAGE CURRENT[mA]	0.75max (60Hz, According to IEC60950 and DEN-AN)											
OUTPUT	VOLTAGE[V]	3.3	5	9	12	15	18	24	24	30	48	
	CURRENT[A]	*1 10	10	5.6	4.3	3.5	2.8	2.1	2.1 (Peak 2.6)	1.7	1.1	
	LINE REGULATION[mV]	20max	20max	36max	48max	60max	72max	96max	96max	120max	192max	
	LOAD REGULATION[mV]	40max	40max	100max	100max	120max	120max	150max	150max	180max	300max	
	RIPPLE[mVp-p]	0 to +50°C *2	80max	80max	120max	120max	120max	120max	150max	150max	180max	300max
		-10 - 0°C *2	140max	140max	160max	160max	160max	160max	160max	160max	160max	200max
	RIPPLE NOISE[mVp-p]	0 to +50°C *2	120max	120max	150max	150max	150max	150max	150max	150max	150max	350max
		-10 - 0°C *2	160max	160max	180max	180max	180max	180max	180max	180max	180max	400max
	TEMPERATURE REGULATION[mV]	0 to +50°C	50max	50max	90max	120max	150max	180max	240max	240max	300max	480max
		-10 to +50°C	60max	60max	120max	150max	180max	200max	290max	290max	360max	600max
	DRIFT[mV]	*3 20max	20max	36max	48max	60max	72max	96max	96max	120max	192max	
	START-UP TIME[ms]	500max (ACIN 100V, Io=100%)										
	HOLD-UP TIME[ms]	20typ (Io=100%)										
	OUTPUT VOLTAGE ADJUSTMENT RANGE[V]	2.85 - 3.6	Fixed (*Y which can be adjusted the output is available as optional: ±10%)									
OUTPUT VOLTAGE SETTING[V]	3.25 - 3.35	4.9 - 5.3	8.6 - 9.4	11.5 - 12.5	14.4 - 15.6	17.3 - 18.7	23.0 - 25.0	23.0 - 25.0	28.5 - 31.5	46.0 - 50.0		
PROTECTION CIRCUIT AND OTHERS	OVERCURRENT PROTECTION	Works over 105% of rating (works over 105% of peak current at option -H) and recovers automatically										
	OVERVOLTAGE PROTECTION	4.00 - 5.25V Works at 115 - 140% of rating										
	OPERATING INDICATION	Not provided										
	REMOTE SENSING	Not provided										
REMOTE ON/OFF	Option (Refer to Instruction Manual)											
ISOLATION	INPUT-OUTPUT · RC	*4 AC3.000V 1minute, Cutoff current = 10mA, DC500V 50MΩ min (At Room Temperature)										
	INPUT-FG	AC2.000V 1minute, Cutoff current = 10mA, DC500V 50MΩ min (At Room Temperature)										
	OUTPUT · RC-FG	*4 AC500V 1minute, Cutoff current = 100mA, DC500V 50MΩ min (At Room Temperature)										
	OUTPUT-RC	*4 AC100V 1minute, Cutoff current = 100mA, DC100V 10MΩ min (At Room Temperature)										
ENVIRONMENT	OPERATING TEMP., HUMID. AND ALTITUDE	-10 to +70°C, 20 - 90%RH (Non condensing) (Refer to DERATING CURVE), 3.000m (10.000feet) max										
	STORAGE TEMP., HUMID. AND ALTITUDE	-20 to +75°C, 20 - 90%RH (Non condensing), 9.000m (30.000feet) max										
	VIBRATION	10 - 55Hz, 19.6m/s ² (2G), 3minutes period, 60minutes each along X, Y and Z axis										
	IMPACT	196.1m/s ² (20G), 11ms, once each X, Y and Z axis										
SAFETY AND NOISE REGULATIONS	AGENCY APPROVALS	UL60950-1, C-UL, EN60950-1, EN60065, EN50178 Complies with DEN-AN and IEC60950-1 (At only AC input)										
	CONDUCTED NOISE	Complies with FCC-B, CISPR22-B, EN55022-B, VCCI-B										
	HARMONIC ATTENUATOR	Complies with IEC61000-3-2										
OTHERS	CASE SIZE/WEIGHT	55×26×195mm (W×H×D) /210g max (without chassis and cover)										
	COOLING METHOD	Convection										

*1 Peak load for 10sec. or less is acceptable if the total wattage is less than the rated wattage.
 *2 This is the value that measured on measuring board with capacitor of 22 μF within 150mm from output terminal.
 Measured by 20MHz oscilloscope or Ripple-Noise meter (Equivalent to KEISOKU-GIKEN: RM101).
 *3 Drift is the change in DC output for an eight hour period after a half-hour warm-up at 25°C,

with the input voltage held constant at the rated input/output.
 *4 Applicable when remote control (optional) is added.
 *5 () : peak current.
 *6 Please contact us about safety approvals for the model with option.
 * Parallel operation with other model is not possible.
 * Derating is required when operated with chassis and cover.

External view

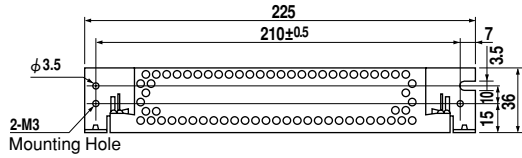
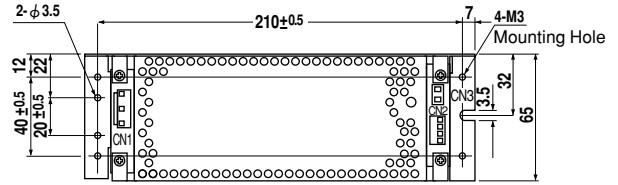
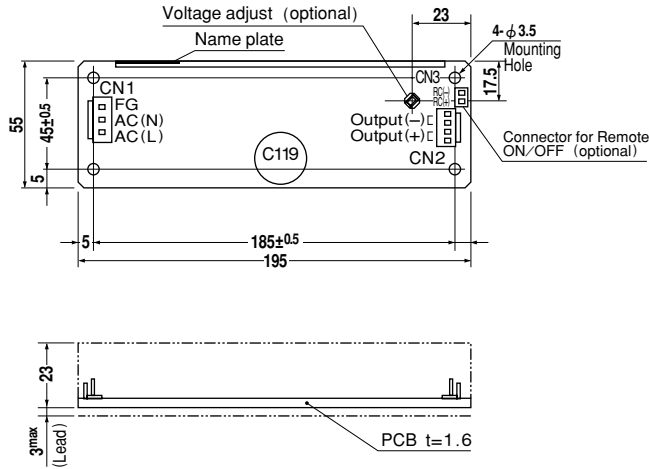

LEA

I / O Connector	Mating Connector	Terminal	
CN1	B3P5-VH	VHR-5N	Chain: SVH-21T-P1.1
			Loose: BVH-21T-P1.1
CN2	B4P-VH	VHR-4N	Chain: SVH-21T-P1.1
			Loose: BVH-21T-P1.1
CN3	B2B-XH-A	XHP-2	Chain: SXH-001T-P0.6
			Loose: BXH-001T-P0.6

Pin No.	Input
1	AC(L)
2	
3	AC(N)
4	
5	FG

Pin No.	Output
1	-V
2	-V
3	+V
4	+V

Pin No.	Remote ON/OFF
1	RC(+)
2	RC(-)

※Weight: 210g or less (Without chassis and cover)
 ※Tolerance: ±1
 ※Dimensions in mm.
 ※PCB Material: Glass composite (CEM3)
 ※Chassis and cover is optional.
 ※Mounting torque: 0.6N·m(6.3kgf·cm)max

(Mfr: J.S.T.) ※Keep drawing current per pin below 5A for CN2

Performance data

RISE TIME & FALL TIME (LEA50F-5)

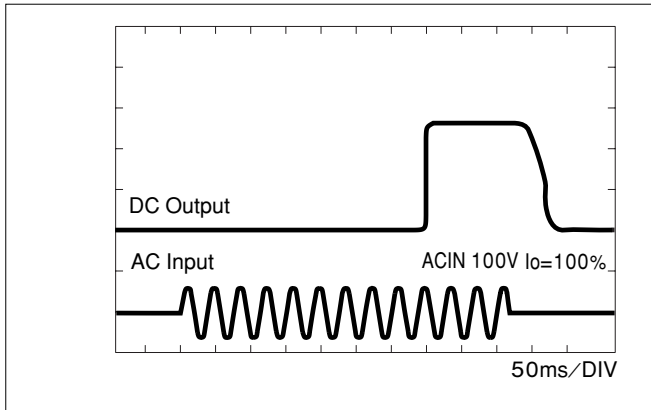

EFFICIENCY (LEA50F-5)

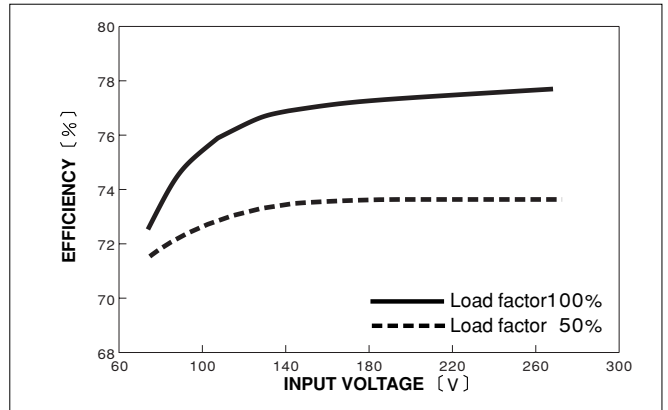

INPUT HARMONIC CURRENT (LEA50F-5)

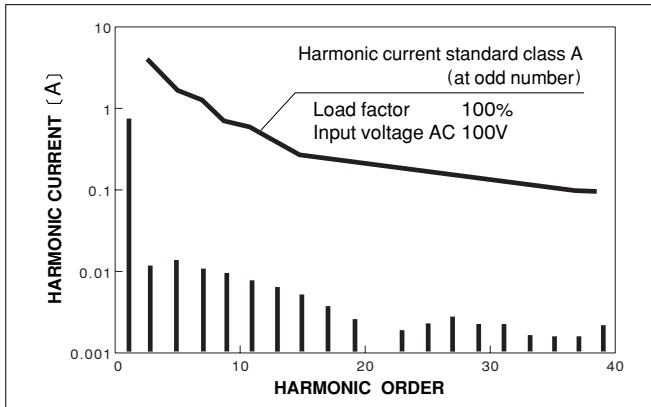

INPUT HARMONIC CURRENT (LEA50F-5)

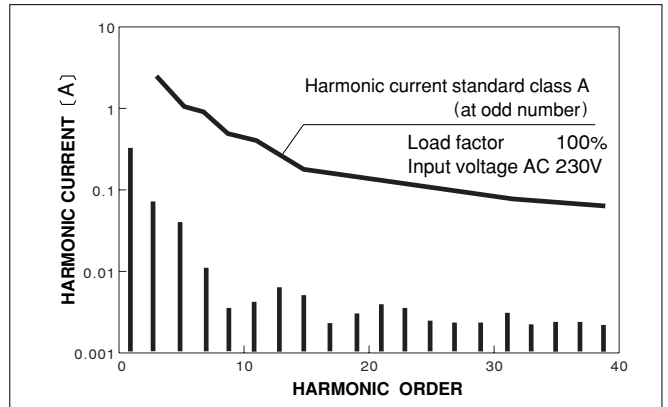

LEA75F

LEA 75 F -5 -□

① ② ③ ④ ⑤

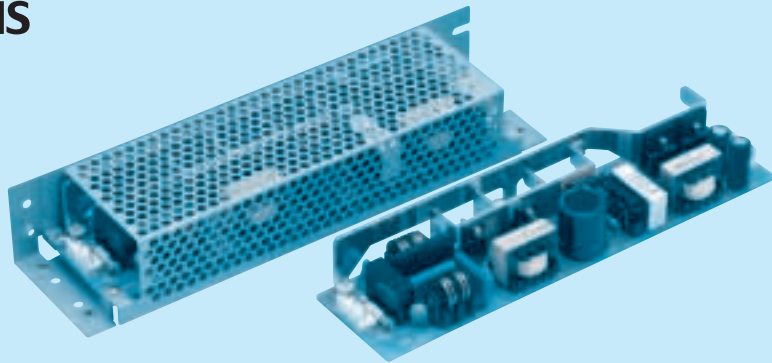

Recommended EMI/EMC Filter
NAC-06-472



High voltage pulse noise type : NAP series
Low leakage current type : NAM series
*The EMI/EMC Filter is recommended to connect with several devices.

- ① Series name
- ② Output wattage
- ③ Universal input
- ④ Output voltage
- ⑤ Optional *6
- C : with Coating
- G : Low leakage current
- J2 : Mini terminal block
- R : with Remote ON/OFF
- S : with Chassis
- SN : with Chassis & cover
- Y : with Potentiometer

LEA

MODEL	LEA75F-3R3-Y	LEA75F-5	LEA75F-9	LEA75F-12	LEA75F-15	LEA75F-18	LEA75F-24	LEA75F-24-H	LEA75F-30	LEA75F-48
MAX OUTPUT WATTAGE[W]	49.5	75	76.5	75.6	75	75.6	76.8	76.8	75	76.8
DC OUTPUT	*5 3.3V 15A	5V 15A	9V 8.5A	12V 6.3A	15V 5A	18V 4.2A	24V 3.2A	24V 3.2(3.8)A	30V 2.5A	48V 1.6A

SPECIFICATIONS

MODEL	LEA75F-3R3-Y	LEA75F-5	LEA75F-9	LEA75F-12	LEA75F-15	LEA75F-18	LEA75F-24	LEA75F-24-H	LEA75F-30	LEA75F-48
INPUT	AC85 - 264 1φ or DC120 - 370									
VOLTAGE[V]	ACIN 100V 0.8									
CURRENT[A]	ACIN 200V 0.4									
FREQUENCY[Hz]	50/60 (47 - 63) or DC									
EFFICIENCY[%]	ACIN 100V 70typ	75typ	78typ	78typ	79typ	81typ	82typ	82typ	82typ	84typ
	ACIN 200V 71typ	77typ	80typ	80typ	81typ	83typ	84typ	84typ	84typ	86typ
POWER FACTOR	ACIN 100V 0.98typ	0.99typ								
	ACIN 200V 0.92typ	0.94typ								
INRUSH CURRENT[A]	ACIN 100V 15typ (Io=100%) (At cold start) (Ta=25°C)									
	ACIN 200V 30typ (Io=100%) (At cold start) (Ta=25°C)									
LEAKAGE CURRENT[mA]	0.75max (60Hz, According to IEC60950 and DEN-AN)									
VOLTAGE[V]	3.3	5	9	12	15	18	24	24	30	48
CURRENT[A]	*1 15	15	8.5	6.3	5	4.2	3.2	3.2 (Peak 3.8)	2.5	1.6
LINE REGULATION[mV]	20max	20max	36max	48max	60max	72max	96max	96max	120max	192max
LOAD REGULATION[mV]	40max	40max	100max	100max	120max	120max	150max	150max	180max	300max
RIPPLE[mVp-p]	0 to +50°C *2 80max	80max	120max	120max	120max	120max	150max	150max	180max	300max
	-10 - 0°C *2 140max	140max	160max	160max	160max	160max	160max	160max	160max	200max
RIPPLE NOISE[mVp-p]	0 to +50°C *2 120max	120max	150max	150max	150max	150max	150max	150max	150max	350max
	-10 - 0°C *2 160max	160max	180max	180max	180max	180max	180max	180max	180max	400max
TEMPERATURE REGULATION[mV]	0 to +50°C 50max	50max	90max	120max	150max	180max	240max	240max	300max	480max
	-10 to +50°C 60max	60max	120max	150max	180max	200max	290max	290max	360max	600max
DRIFT[mV]	*3 20max	20max	36max	48max	60max	72max	96max	96max	120max	192max
START-UP TIME[ms]	500max (ACIN 100V, Io=100%)									
HOLD-UP TIME[ms]	20typ (Io=100%)									
OUTPUT VOLTAGE ADJUSTMENT RANGE[V]	2.85 - 3.6	Fixed (*Y which can be adjusted the output is available as optional: ±10%)								
OUTPUT VOLTAGE SETTING[V]	3.25 - 3.35	4.9 - 5.3	8.6 - 9.4	11.5 - 12.5	14.4 - 15.6	17.3 - 18.7	23.0 - 25.0	23.0 - 25.0	28.5 - 31.5	46.0 - 50.0
PROTECTION CIRCUIT AND OTHERS	OVERCURRENT PROTECTION Works over 105% of rating (works over 105% of peak current at option -H) and recovers automatically									
	OVERVOLTAGE PROTECTION 4.00 - 5.25V Works at 115 - 140% of rating									
	OPERATING INDICATION Not provided									
	REMOTE SENSING Not provided									
	REMOTE ON/OFF Option (Refer to Instruction Manual)									
ISOLATION	INPUT-OUTPUT · RC *4 AC3.000V 1minute, Cutoff current = 10mA, DC500V 50MΩ min (At Room Temperature)									
	INPUT-FG AC2.000V 1minute, Cutoff current = 10mA, DC500V 50MΩ min (At Room Temperature)									
	OUTPUT · RC-FG *4 AC500V 1minute, Cutoff current = 100mA, DC500V 50MΩ min (At Room Temperature)									
	OUTPUT-RC *4 AC100V 1minute, Cutoff current = 100mA, DC100V 10MΩ min (At Room Temperature)									
ENVIRONMENT	OPERATING TEMP., HUMID. AND ALTITUDE -10 to +70°C, 20 - 90%RH (Non condensing) (Refer to DERATING CURVE), 3.000m (10.000feet) max									
	STORAGE TEMP., HUMID. AND ALTITUDE -20 to +75°C, 20 - 90%RH (Non condensing), 9.000m (30.000feet) max									
	VIBRATION 10 - 55Hz, 19.6m/s ² (2G), 3minutes period, 60minutes each along X, Y and Z axis									
	IMPACT 196.1m/s ² (20G), 11ms, once each X, Y and Z axis									
SAFETY AND NOISE REGULATIONS	AGENCY APPROVALS UL60950-1, C-UL, EN60950-1, EN60065, EN50178 Complies with DEN-AN and IEC60950-1 (At only AC input)									
	CONDUCTED NOISE Complies with FCC-B, CISPR22-B, EN55022-B, VCCI-B									
	HARMONIC ATTENUATOR Complies with IEC61000-3-2									
OTHERS	CASE SIZE/WEIGHT 55 x 32 x 222mm (W x H x D) /290g max (without chassis and cover)									
	COOLING METHOD Convection									

*1 Peak load for 10 sec. or less is acceptable if the total wattage is less than the rated wattage.
*2 This is the value that measured on measuring board with capacitor of 22 μF within 150mm from output terminal.
Measured by 20MHz oscilloscope or Ripple-Noise meter (Equivalent to KEISOKU-GIKEN: RM101).
*3 Drift is the change in DC output for an eight hour period after a half-hour warm-up at 25°C,

with the input voltage held constant at the rated input/output.
*4 Applicable when remote control (optional) is added.
*5 (): peak current.
*6 Please contact us about safety approvals for the model with option.
* Parallel operation with other model is not possible.
* Derating is required when operated with chassis and cover.

External view

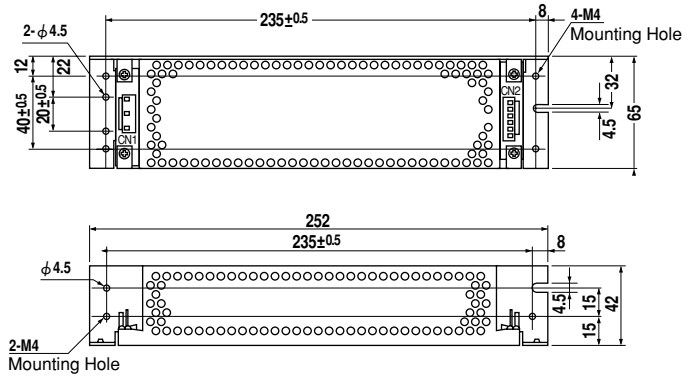
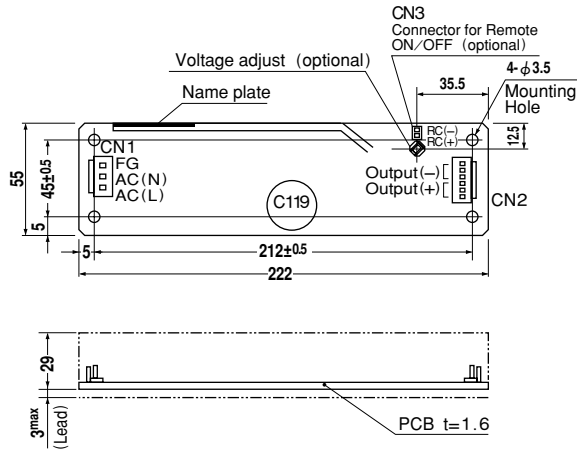

I / O Connector	Mating Connector	Terminal
CN1	B3P5-VH	VHR-5N
CN2	B6P-VH	VHR-6N
CN3	B2B-XH-A	XHP-2

(PIN CONNECTION)

Pin No.	Input
1	AC(L)
2	
3	AC(N)
4	
5	FG

Pin No.	Output
1~3	-V
4~6	+V

(Optional)

Pin No.	Remote ON/OFF
1	RC(+)
2	RC(-)

- ※Weight: 290g or less (Without chassis and cover)
- ※Tolerance: ±1
- ※Dimensions in mm.
- ※PCB Material: Glass composite (CEM3)
- ※Chassis and cover is optional.
- ※Chassis and cover is not available to remote ON/OFF unit.
- ※Mounting torque: 1.5N·m(16kgf·cm)max

Performance data

RISE TIME & FALL TIME (LEA75F-5)

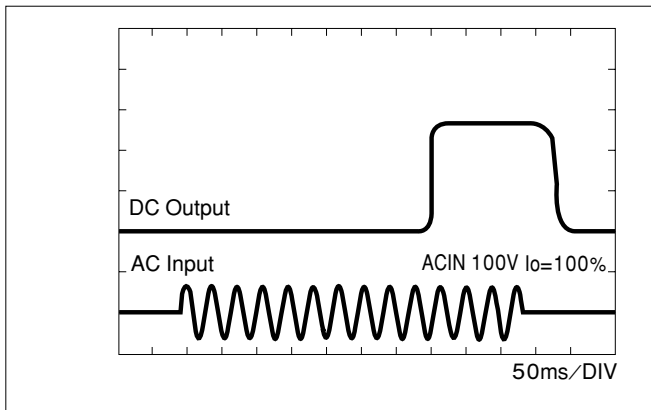

EFFICIENCY (LEA75F-5)

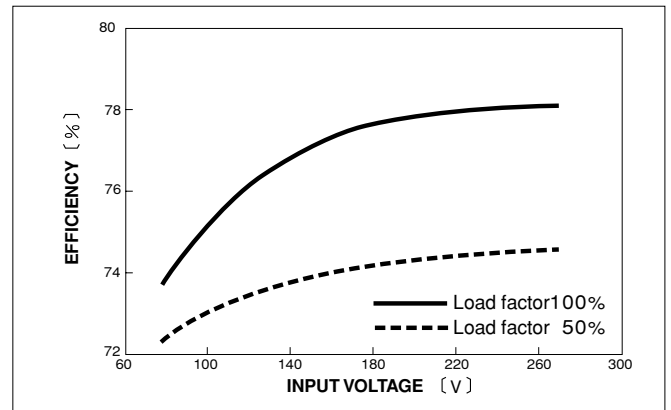

INPUT HARMONIC CURRENT (LEA75F-5)

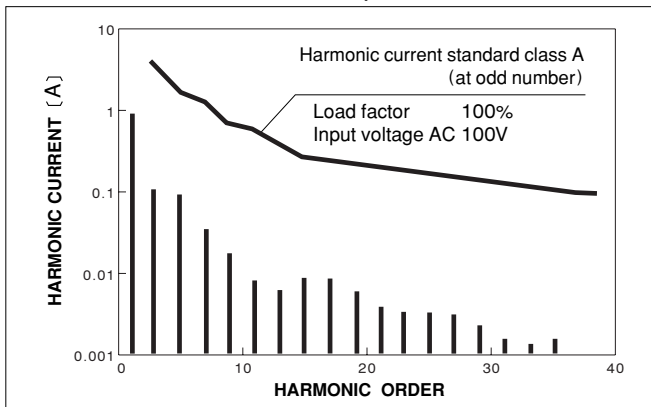

INPUT HARMONIC CURRENT (LEA75F-5)

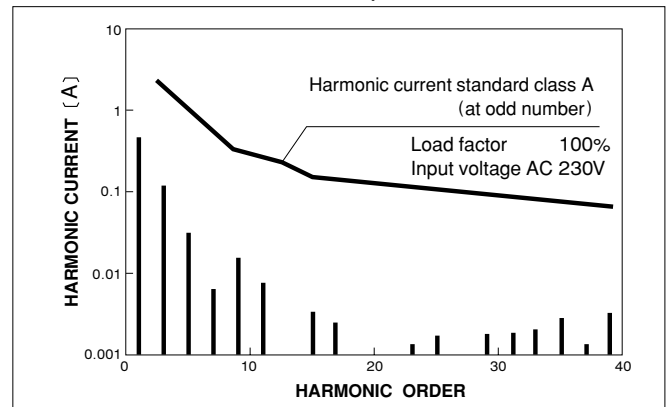

LEA100F

LEA 100 F -5 -□

① ② ③ ④ ⑤



Recommended EMI/EMC Filter
NAC-06-472



High voltage pulse noise type : NAP series
Low leakage current type : NAM series
*The EMI/EMC Filter is recommended to connect with several devices.

- ① Series name
- ② Output wattage
- ③ Universal input
- ④ Output voltage
- ⑤ Optional *6
- C :with Coating
- G :Low leakage current
- J2:Mini terminal block
- R :with Remote ON/OFF
- S :with Chassis
- SN:with Chassis & cover
- Y :with Potentiometer

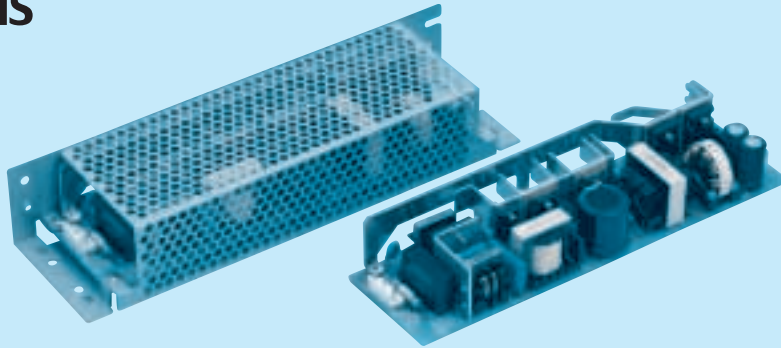

LEA

MODEL	LEA100F-3R3-Y	LEA100F-5	LEA100F-9	LEA100F-12	LEA100F-15	LEA100F-18	LEA100F-24	LEA100F-24-H	LEA100F-30	LEA100F-48
MAX OUTPUT WATTAGE[W]	66	100	103.5	102	100.5	100.8	103.2	103.2	105	105.6
DC OUTPUT	*5 3.3V 20A	5V 20A	9V 11.5A	12V 8.5A	15V 6.7A	18V 5.6A	24V 4.3A	24V 4.3(5.0)A	30V 3.5A	48V 2.2A

SPECIFICATIONS

MODEL	LEA100F-3R3-Y	LEA100F-5	LEA100F-9	LEA100F-12	LEA100F-15	LEA100F-18	LEA100F-24	LEA100F-24-H	LEA100F-30	LEA100F-48
INPUT	VOLTAGE[V] AC85 - 264 1 φ or DC120 - 370 CURRENT[A] ACIN 100V 1.0 1.4typ ACIN 200V 0.5 0.7typ FREQUENCY[Hz] 50/60 (47 - 63) or DC EFFICIENCY[%] ACIN 100V 71typ 75typ 79typ 79typ 79typ 81typ 81typ 81typ 82typ 83typ ACIN 200V 73typ 78typ 81typ 81typ 82typ 83typ 84typ 84typ 84typ 85typ 85typ POWER FACTOR ACIN 100V 0.98typ 0.99typ ACIN 200V 0.92typ 0.94typ INRUSH CURRENT[A] ACIN 100V 15typ (Io=100%) (At cold start) (Ta=25°C) ACIN 200V 30typ (Io=100%) (At cold start) (Ta=25°C) LEAKAGE CURRENT[mA] 0.75max (60Hz, According to IEC60950 and DEN-AN)									
OUTPUT	VOLTAGE[V] 3.3 5 9 12 15 18 24 24 30 48 CURRENT[A] *1 20 20 11.5 8.5 6.7 5.6 4.3 4.3 (Peak 5.0) 3.5 2.2 LINE REGULATION[mV] 20max 20max 36max 48max 60max 72max 96max 96max 120max 192max LOAD REGULATION[mV] 40max 40max 100max 100max 120max 120max 150max 150max 180max 300max RIPPLE[mVp-p] 0 to +50°C *2 80max 80max 120max 120max 120max 120max 150max 150max 180max 400max -10 - 0°C *2 140max 140max 160max 160max 160max 160max 160max 160max 160max 200max RIPPLE NOISE[mVp-p] 0 to +50°C *2 120max 120max 150max 150max 150max 150max 150max 150max 150max 350max -10 - 0°C *2 160max 160max 180max 180max 180max 180max 180max 180max 180max 400max TEMPERATURE REGULATION[mV] 0 to +50°C 50max 50max 90max 120max 150max 180max 240max 240max 300max 480max -10 to +50°C 60max 60max 120max 150max 180max 200max 290max 290max 360max 600max DRIFT[mV] *3 20max 20max 36max 48max 60max 72max 96max 96max 120max 192max START-UP TIME[ms] 500max (ACIN 100V, Io=100%) HOLD-UP TIME[ms] 20typ (Io=100%) OUTPUT VOLTAGE ADJUSTMENT RANGE[V] 2.85 - 3.6 Fixed (*Y which can be adjusted the output is available as optional: ±10%) OUTPUT VOLTAGE SETTING[V] 3.25 - 3.35 4.9 - 5.3 8.6 - 9.4 11.5 - 12.5 14.4 - 15.6 17.3 - 18.7 23.0 - 25.0 23.0 - 25.0 28.5 - 31.5 46.0 - 50.0									
PROTECTION CIRCUIT AND OTHERS	OVERCURRENT PROTECTION Works over 105% of rating (works over 105% of peak current at option -H) and recovers automatically OVERVOLTAGE PROTECTION 4.00 - 5.25V Works at 115 - 140% of rating OPERATING INDICATION Not provided REMOTE SENSING Not provided REMOTE ON/OFF Option (Refer to Instruction Manual)									
ISOLATION	INPUT-OUTPUT · RC *4 AC3.000V 1minute, Cutoff current = 10mA, DC500V 50MΩ min (At Room Temperature) INPUT-FG AC2.000V 1minute, Cutoff current = 10mA, DC500V 50MΩ min (At Room Temperature) OUTPUT · RC-FG *4 AC500V 1minute, Cutoff current = 100mA, DC500V 50MΩ min (At Room Temperature) OUTPUT-RC *4 AC100V 1minute, Cutoff current = 100mA, DC100V 10MΩ min (At Room Temperature)									
ENVIRONMENT	OPERATING TEMP., HUMID. AND ALTITUDE -10 to +70°C, 20 - 90%RH (Non condensing) (Refer to DERATING CURVE), 3.000m (10.000feet) max STORAGE TEMP., HUMID. AND ALTITUDE -20 to +75°C, 20 - 90%RH (Non condensing), 9.000m (30.000feet) max VIBRATION 10 - 55Hz, 19.6m/s ² (2G), 3minutes period, 60minutes each along X, Y and Z axis IMPACT 196.1m/s ² (20G), 11ms, once each X, Y and Z axis									
SAFETY AND NOISE REGULATIONS	AGENCY APPROVALS UL60950-1, C-UL, EN60950-1, EN60065, EN50178 Complies with DEN-AN and IEC60950-1 (At only AC input) CONDUCTED NOISE Complies with FCC-B, CISPR22-B, EN55022-B, VCCI-B HARMONIC ATTENUATOR Complies with IEC61000-3-2									
OTHERS	CASE SIZE/WEIGHT 62 X 35 X 222mm (W X H X D) /380g max (without chassis and cover) COOLING METHOD Convection									

*1 Peak load for 10 sec. or less is acceptable if the total wattage is less than the rated wattage.
 *2 This is the value that measured on measuring board with capacitor of 22 μF within 150mm from output terminal.
 Measured by 20MHz oscilloscope or Ripple-Noise meter (Equivalent to KEISOKU-GIKEN: RM101).
 *3 Drift is the change in DC output for an eight hour period after a half-hour warm-up at 25°C,

with the input voltage held constant at the rated input/output.
 *4 Applicable when remote control (optional) is added.
 *5 () : peak current.
 *6 Please contact us about safety approvals for the model with option.
 * Parallel operation with other model is not possible.
 * Derating is required when operated with chassis and cover.

External view

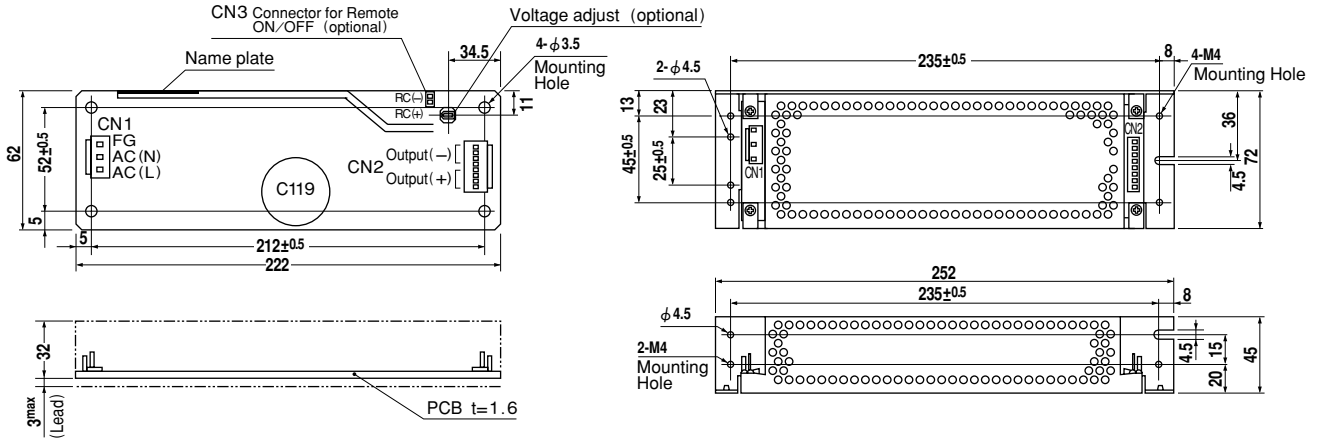

LEA

I / O Connector	Mating Connector	Terminal	
CN1	B3P5-VH	VHR-5N	Chain: SVH-21T-P1.1
			Loose: BVH-21T-P1.1
CN2	B8P-VH	VHR-8N	Chain: SVH-21T-P1.1
			Loose: BVH-21T-P1.1
CN3	B2B-XH-A	XHP-2	Chain: SXH-001T-P0.6
			Loose: BXH-001T-P0.6

Pin No.	Input
1	AC(L)
2	
3	AC(N)
4	
5	FG

Pin No.	Output
1~4	-V
5~8	+V

Pin No.	Remote ON/OFF
1	RC(+)
2	RC(-)

(Mfr: J.S.T.)

※Keep drawing current per pin below 5A for CN2

- ※Weight: 380g or less (Without chassis and cover)
- ※Tolerance: ±1
- ※Dimensions in mm.
- ※PCB Material: Glass composite (CEM3)
- ※Chassis and cover is optional.
- ※Chassis and cover is not available to remote ON/OFF unit.
- ※Mounting torque: 1.5N·m(16kgf·cm)max

Performance data

RISE TIME & FALL TIME (LEA100F-5)

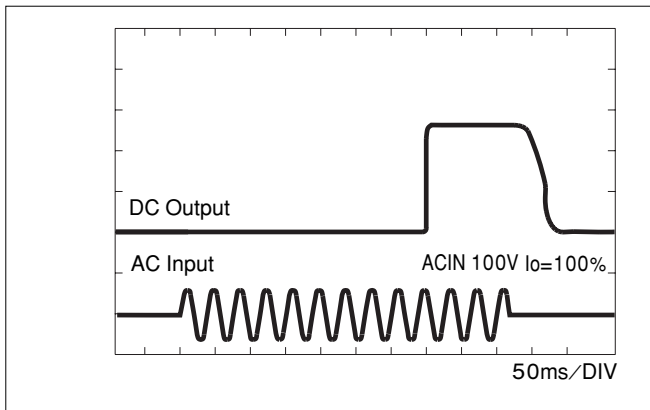

EFFICIENCY (LEA100F-5)

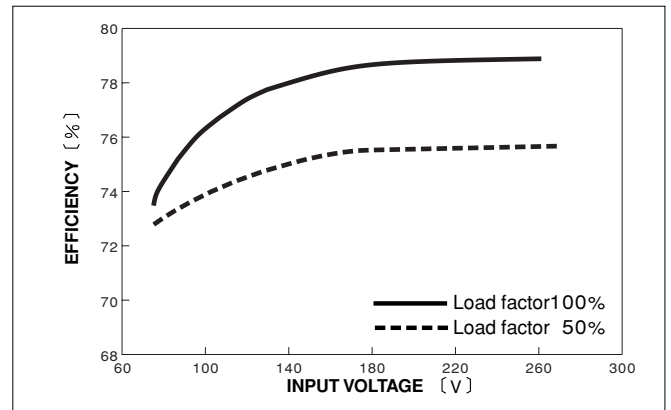

INPUT HARMONIC CURRENT (LEA100F-5)

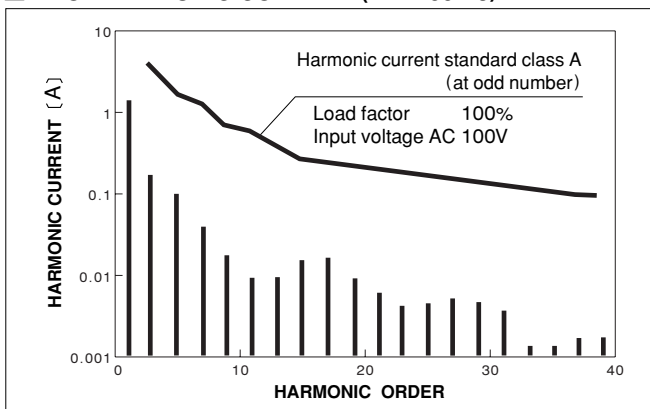

INPUT HARMONIC CURRENT (LEA100F-5)

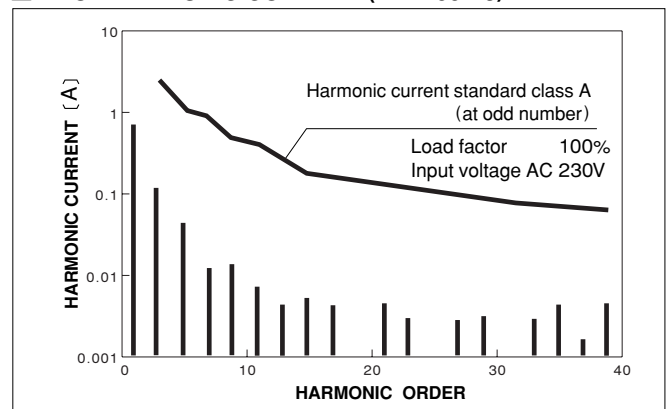

LEA150F

LEA 150 F -5 -□

① ② ③ ④ ⑤

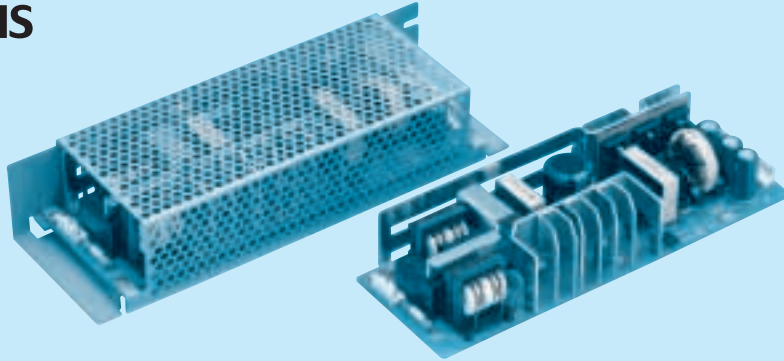

Recommended EMI/EMC Filter
NAC-06-472



High voltage pulse noise type : NAP series
Low leakage current type : NAM series
*The EMI/EMC Filter is recommended to connect with several devices.

- ① Series name
- ② Output wattage
- ③ Universal input
- ④ Output voltage
- ⑤ Optional *6
- C : with Coating
- G : Low leakage current
- J2 : Mini terminal block
- R : with Remote ON/OFF
- S : with Chassis
- SN : with Chassis & cover
- Y : with Potentiometer

LEA

MODEL	LEA150F-3R3-Y	LEA150F-5	LEA150F-9	LEA150F-12	LEA150F-15	LEA150F-18	LEA150F-24	LEA150F-24-H	LEA150F-30	LEA150F-48
MAX OUTPUT WATTAGE[W]	99	150	153	150	150	153	151.2	151.2	150	153.6
DC OUTPUT	*5 3.3V 30A	5V 30A	9V 17A	12V 12.5A	15V 10A	18V 8.5A	24V 6.3A	24V 6.3(7.5)A	30V 5A	48V 3.2A

SPECIFICATIONS

MODEL	LEA150F-3R3-Y	LEA150F-5	LEA150F-9	LEA150F-12	LEA150F-15	LEA150F-18	LEA150F-24	LEA150F-24-H	LEA150F-30	LEA150F-48
INPUT	VOLTAGE[V] AC85 - 264 1φ or DC120 - 370 CURRENT[A] ACIN 100V 1.4 2.0typ ACIN 200V 0.7 1.0typ FREQUENCY[Hz] 50/60 (47 - 63) or DC EFFICIENCY[%] ACIN 100V 71typ 76typ 79typ 78typ 80typ 81typ 81typ 81typ 84typ 84typ ACIN 200V 74typ 79typ 82typ 81typ 83typ 84typ 84typ 84typ 87typ 87typ POWER FACTOR ACIN 100V 0.98typ 0.99typ ACIN 200V 0.91typ 0.94typ INRUSH CURRENT[A] ACIN 100V 15typ (Io=100%) (At cold start) (Ta=25°C) ACIN 200V 30typ (Io=100%) (At cold start) (Ta=25°C) LEAKAGE CURRENT[mA] 0.75max (60Hz, According to IEC60950 and DEN-AN)									
OUTPUT	VOLTAGE[V] 3.3 5 9 12 15 18 24 24 30 48 CURRENT[A] *1 30 30 17 12.5 10 8.5 6.3 6.3 (Peak 7.5) 5 3.2 LINE REGULATION[mV] 20max 20max 36max 48max 60max 72max 96max 96max 120max 192max LOAD REGULATION[mV] 40max 40max 100max 100max 120max 120max 150max 150max 180max 300max RIPPLE[mVp-p] 0 to +50°C *2 80max 80max 120max 120max 120max 120max 120max 120max 120max 150max -10 - 0°C *2 140max 140max 160max 160max 160max 160max 160max 160max 160max 200max RIPPLE NOISE[mVp-p] 0 to +50°C *2 120max 120max 150max 150max 150max 150max 150max 150max 150max 350max -10 - 0°C *2 160max 160max 180max 180max 180max 180max 180max 180max 180max 400max TEMPERATURE REGULATION[mV] 0 to +50°C 50max 50max 90max 120max 150max 180max 240max 240max 300max 480max -10 to +50°C 60max 60max 120max 150max 180max 200max 290max 290max 360max 600max DRIFT[mV] *3 20max 20max 36max 48max 60max 72max 96max 96max 120max 192max START-UP TIME[ms] 500max (ACIN 100V, Io=100%) HOLD-UP TIME[ms] 20typ (Io=100%) OUTPUT VOLTAGE ADJUSTMENT RANGE[V] 2.85 - 3.6 Fixed (*Y which can be adjusted the output is available as optional: ±10%) OUTPUT VOLTAGE SETTING[V] 3.25 - 3.35 4.9 - 5.3 8.6 - 9.4 11.5 - 12.5 14.4 - 15.6 17.3 - 18.7 23.0 - 25.0 23.0 - 25.0 28.5 - 31.5 46.0 - 50.0									
PROTECTION CIRCUIT AND OTHERS	OVERCURRENT PROTECTION Works over 105% of rating (works over 105% of peak current at option -H) and recovers automatically OVERVOLTAGE PROTECTION 4.00 - 5.25V Works at 115 - 140% of rating OPERATING INDICATION Not provided REMOTE SENSING Not provided REMOTE ON/OFF Option (Refer to Instruction Manual)									
ISOLATION	INPUT-OUTPUT · RC *4 AC3.000V 1minute, Cutoff current = 10mA, DC500V 50MΩ min (At Room Temperature) INPUT-FG AC2.000V 1minute, Cutoff current = 10mA, DC500V 50MΩ min (At Room Temperature) OUTPUT · RC-FG *4 AC500V 1minute, Cutoff current = 100mA, DC500V 50MΩ min (At Room Temperature) OUTPUT-RC *4 AC100V 1minute, Cutoff current = 100mA, DC100V 10MΩ min (At Room Temperature)									
ENVIRONMENT	OPERATING TEMP., HUMID. AND ALTITUDE -10 to +60°C, 20 - 90%RH (Non condensing) (Refer to DERATING CURVE), 3.000m (10.000feet) max STORAGE TEMP., HUMID. AND ALTITUDE -20 to +75°C, 20 - 90%RH (Non condensing), 9.000m (30.000feet) max VIBRATION 10 - 55Hz, 19.6m/s ² (2G), 3minutes period, 60minutes each along X, Y and Z axis IMPACT 196.1m/s ² (20G), 11ms, once each X, Y and Z axis									
SAFETY AND NOISE REGULATIONS	AGENCY APPROVALS UL60950-1, C-UL, EN60950-1, EN60065, EN50178 Complies with DEN-AN and IEC60950-1 (At only AC input) CONDUCTED NOISE Complies with FCC-B, CISPR22-B, EN55022-B, VCCI-B HARMONIC ATTENUATOR Complies with IEC61000-3-2									
OTHERS	CASE SIZE/WEIGHT 75 × 40 × 222mm (W × H × D) /500g max (without chassis and cover) COOLING METHOD Convection									

*1 Peak load for 10 sec. or less is acceptable if the total wattage is less than the rated wattage.
 *2 This is the value that measured on measuring board with capacitor of 22 μF within 150mm from output terminal.
 Measured by 20MHz oscilloscope or Ripple-Noise meter (Equivalent to KEISOKU-GIKEN: RM101).
 *3 Drift is the change in DC output for an eight hour period after a half-hour warm-up at 25°C,

with the input voltage held constant at the rated input/output.
 *4 Applicable when remote control (optional) is added.
 *5 (): peak current.
 *6 Please contact us about safety approvals for the model with option.
 * Parallel operation with other model is not possible.
 * Derating is required when operated with chassis and cover.

External view

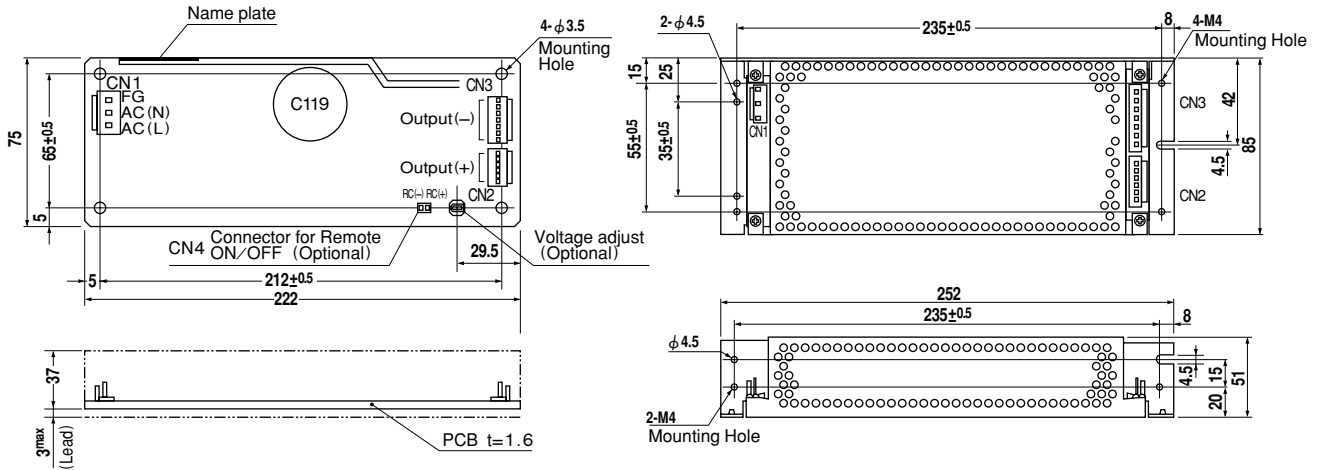

LEA

I / O Connector	Mating Connector	Terminal
CN1	B3P5-VH	VHR-5N
		Chain: SVH-21T-P1.1
		Loose: BVH-21T-P1.1
CN2	B6P-VH	VHR-6N
		Chain: SVH-21T-P1.1
		Loose: BVH-21T-P1.1
CN3	B7P-VH	VHR-7N
		Chain: SVH-21T-P1.1
		Loose: BVH-21T-P1.1
CN4	B2B-XH-A	XHP-2
		Chain: SXH-001T-P0.6
		Loose: BXH-001T-P0.6

(Mfr: J.S.T.)

(PIN CONNECTION)

Pin No.	Input
1	AC(L)
2	AC(N)
3	AC(N)
4	AC(N)
5	FG

※Keep drawing current per pin below 5A for CN2, CN3

(Optional)

Pin No.	Output	Pin No.	Remote ON/OFF
CN2 1~6	+V	1	RC(+)
CN3 1~7	-V	2	RC(-)

- ※Weight: 500g or less (Without chassis and cover)
- ※Tolerance: ±1
- ※Dimensions in mm.
- ※PCB Material: Glass composite (CEM3)
- ※Chassis and cover is optional.
- ※Chassis and cover is not available to remote ON/OFF unit.
- ※Mounting torque: 1.5N·m(16kgf·cm)max

Performance data

RISE TIME & FALL TIME (LEA150F-5)

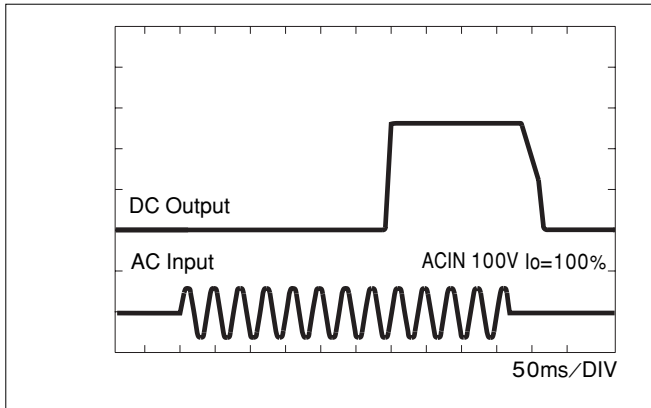

EFFICIENCY (LEA150F-5)

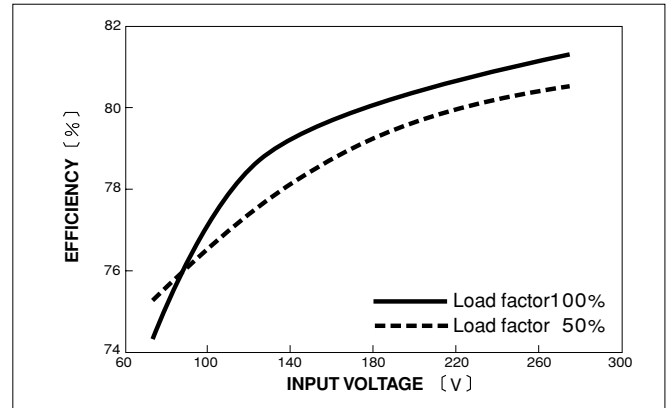

INPUT HARMONIC CURRENT (LEA150F-5)

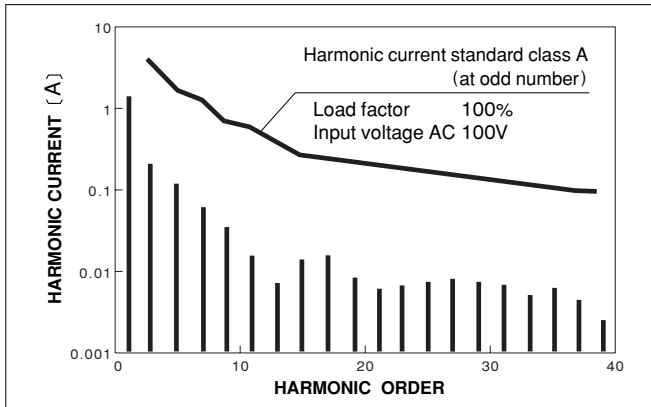

INPUT HARMONIC CURRENT (LEA150F-5)

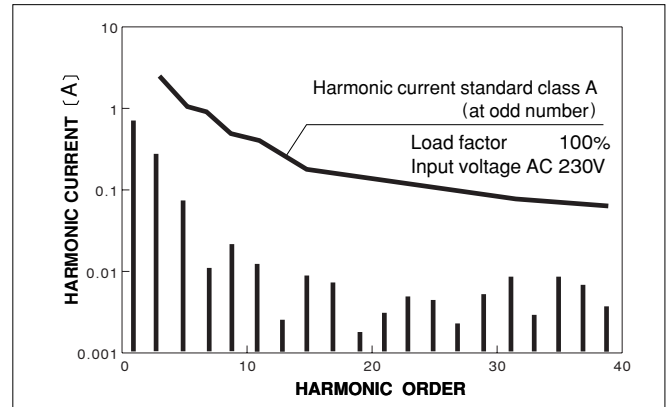

X-ON Electronics

Largest Supplier of Electrical and Electronic Components

Click to view similar products for [Switching Power Supplies](#) category:

Click to view products by [Cosel](#) manufacturer:

Other Similar products are found below :

[70841011](#) [73-551-0005](#) [73-551-0048](#) [PS3E-B12F](#) [PS3E-E12F](#) [AAD600S-4-OP](#) [R22095](#) [KD0204](#) [9021](#) [LDIN100150](#) [LPM000-BBAR-01](#)
[LPX17S-C](#) [EVS57-10R6/R](#) [FP80](#) [FRV7000G](#) [22929](#) [PS3E-F12F](#) [CQM1IA121](#) [40370121900](#) [VI-PU22-EXX](#) [40370121910](#) [LDIN5075](#)
[LPM615-CHAS](#) [LPX140-C](#) [09-160CFG](#) [70841025](#) [VPX3000-CBL-DC](#) [VI-LUL-IU](#) [LPM000-BBAR-05](#) [LPM000-BBAR-08](#) [LPM124-](#)
[OUTA1-48](#) [LPM000-BBAR-07](#) [LPM109-OUTA1-10](#) [LPM616-CHAS](#) [08-30466-1055G](#) [08-30466-2175G](#) [08-30466-2125G](#) [DMB-EWG](#)
[TVQF-1219-18S](#) [6504-226-2101](#) [CQM1IPS01](#) [SP-300-5](#) [CQM1-IPS02](#) [VI-MUL-ES](#) [22829](#) [08-30466-0065G](#) [VI-RU031-EWWX](#) [08-30466-](#)
[0028G](#) [EP3000AC48INZ](#) [VP-C2104853](#)