**Recommended Noise Filter
NAC-20-472**

High voltage pulse noise type : NAP series
Low leakage current type : NAM series
*The Noise Filter is recommended to connect with several devices.

- ① Series name
② Single output
③ Output wattage
④ Universal input
⑤ Output voltage
⑥ Optional
C : with Coating
G : Low leakage current
U : Operation stop voltage is set at a lower value
F1 : With Long-Life fan
F3 : Reverse air exhaust type
F4 : Low speed fan

Refer to instruction manual 7.1.

MODEL	PBA1000F-3R3	PBA1000F-5	PBA1000F-7R5	PBA1000F-12	PBA1000F-15	PBA1000F-24	PBA1000F-36	PBA1000F-48	
MAX OUTPUT WATTAGE[W]	660	1000	1005	1056	1050	1056	1044	1056	
DC OUTPUT	ACIN 100V	3.3V 200A	5V 200A	7.5V 134A	12V 88A	15V 70A	24V 44A	36V 29A	48V 22A
	ACIN 200V *3	3.3V 200A	5V 200A	7.5V 134A	12V 88A	15V 70A	24V 44(51)A	36V 29A	48V 22A

SPECIFICATIONS

MODEL	PBA1000F-3R3	PBA1000F-5	PBA1000F-7R5	PBA1000F-12	PBA1000F-15	PBA1000F-24	PBA1000F-36	PBA1000F-48		
INPUT	VOLTAGE[V]	AC85 - 264 1φ or DC120 - 350 (AC50 or DC70 Please refer to the instruction manual 7. option *5)								
	CURRENT[A]	ACIN 100V	9typ	13typ						
		ACIN 200V	5typ	7typ						
	FREQUENCY[Hz]	50/60 (47 - 63)								
	EFFICIENCY[%]	ACIN 100V	74typ	79typ	80typ	82typ	82typ	84typ	84typ	
		ACIN 200V	76typ	81typ	83typ	84typ	84typ	86typ	86typ	
	POWER FACTOR	ACIN 100V	0.98typ (Io=100%)							
		ACIN 200V	0.95typ (Io=100%)							
INRUSH CURRENT[A]	ACIN 100V	20/40typ (Io=100%) (Primary inrush current /Secondary inrush current) (More than 10 sec. to re-start)								
	ACIN 200V	40/40typ (Io=100%) (Primary inrush current /Secondary inrush current) (More than 10 sec. to re-start)								
LEAKAGE CURRENT[mA]	0.5/1.0max (ACIN 100V/240V 60Hz. Io=100%, According to IEC60950-1, DENAN)									
OUTPUT	VOLTAGE[V]	3.3	5	7.5	12	15	24	36	48	
	CURRENT[A]	ACIN 100V	200	200	134	88	70	44	29	22
		ACIN 200V *3	200	200	134	88	70	44(51)	29	22
	LINE REGULATION[mV]	20max	20max	36max	48max	60max	96max	144max	192max	
	LOAD REGULATION[mV]	40max	40max	60max	100max	120max	150max	150max	300max	
	RIPPLE[mVp-p]	0 to +50C *1	80max	80max	120max	120max	120max	120max	150max	150max
		-20 - 0C *1	140max	140max	160max	160max	160max	160max	160max	400max
	RIPPLE NOISE[mVp-p]	0 to +50C *1	120max	120max	150max	150max	150max	150max	200max	200max
		-20 - 0C *1	160max	160max	180max	180max	180max	180max	240max	500max
	TEMPERATURE REGULATION[mV]	0 to +50C *1	40max	50max	75max	120max	150max	240max	360max	480max
		-20 to +50C *1	60max	75max	120max	180max	180max	290max	440max	600max
	DRIFT[mV]	*2	12max	20max	30max	48max	60max	96max	144max	192max
	START-UP TIME[ms]	400typ(ACIN 100/200V, Io=100%) *Start-up time is 500ms typ for less than 1minute of applying input again from turning off the input voltage.								
HOLD-UP TIME[ms]	20typ (ACIN 100/200V, Io=100%)									
OUTPUT VOLTAGE ADJUSTMENT RANGE[V]	2.64 - 3.96	3.96 - 6.00	5.25 - 8.25	8.25 - 13.20	10.50 - 16.50	16.50 - 26.40	25.20 - 39.60	38.40 - 56.00		
OUTPUT VOLTAGE SETTING[V]	3.30 - 3.40	5.00 - 5.15	7.50 - 7.80	12.00 - 12.48	15.00 - 15.60	24.00 - 24.96	36.00 - 37.44	48.00 - 49.92		
PROTECTION CIRCUIT AND OTHERS	OVERCURRENT PROTECTION	Works over 105% of rated current or 101% of peak current and recovers automatically								
	OVERVOLTAGE PROTECTION[V] *4	Vo+0.66 - 1.32	Vo+1.0 - 2.0	Vo+1.5 - 3.0	Vo+2.4 - 4.8	Vo+3.0 - 6.0	Vo+4.8 - 9.6	Vo+7.2 - 14.4	Vo+4.8 - 12.0	
	OPERATING INDICATION	LED (Green)								
	REMOTE SENSING	Provided								
ISOLATION	REMOTE ON/OFF	Provided								
	INPUT-OUTPUT · RC	AC3.000V 1minute, Cutoff current = 25mA, DC500V 50MΩmin (At Room Temperature)								
	INPUT-FG	AC2.000V 1minute, Cutoff current = 25mA, DC500V 50MΩmin (At Room Temperature)								
	OUTPUT · RC · AUX-FG	AC500V 1minute, Cutoff current = 100mA, DC500V 50MΩmin (At Room Temperature)								
ENVIRONMENT	OUTPUT-RC · AUX	AC100V 1minute, Cutoff current = 100mA, DC100V 50MΩmin (At Room Temperature)								
	OPERATING TEMP.,HUMID.AND ALTITUDE	-20 to +71°C (Required Derating), 20 - 90%RH (Non condensing) 3,000m (10,000feet) max								
	STORAGE TEMP.,HUMID.AND ALTITUDE	-20 to +75°C, 20 - 90%RH (Non condensing) 3,000m (10,000feet) max								
	VIBRATION	10 - 55Hz, 19.6m/s ² (2G), 3minutes period, 60minutes each along X, Y and Z axis								
SAFETY AND NOISE REGULATIONS	IMPACT	196.1m/s ² (20G), 11ms, once each X, Y and Z axis								
	AGENCY APPROVALS (At only AC input)	UL60950-1, C-UL(CSA60950-1), EN60950-1, EN50178 Complies with DEN-AN								
	CONDUCTED NOISE	Complies with FCC Part15 classB, VCCI-B, CISPR22-B, EN55011-B, EN55022-B								
	CE MARKING	Low Voltage Directive, EMC Directive								
OTHERS	HARMONIC ATTENUATOR	Complies with IEC61000-3-2								
	CASE SIZE/WEIGHT	150×61×240mm (without terminal block and screw) (W×H×D) /2.2kg max								
	COOLING METHOD	Forced cooling (internal fan)								

*1 Measured by 20MHz oscilloscope or Ripple-Noise meter(equivalent to KEISOKU-GIKEN :RM101).
Ripple and ripple noise is measured on measuring board with capacitor of 22 μF within 150mm from the output terminal.

*2 Drift is the change in DC output for an eight hour period after a half-hour warm-up at 25°C.

*3 () means peak current. Peak loading for 10s. And Duty 35% max, refer to Instruction manual

in detail.

*4 Overvoltage protection circuit to follow to output voltage setting.

*5 Derating is required.Consult us for details.

* A sound may occur from power supply at pulse loading.

Block diagram

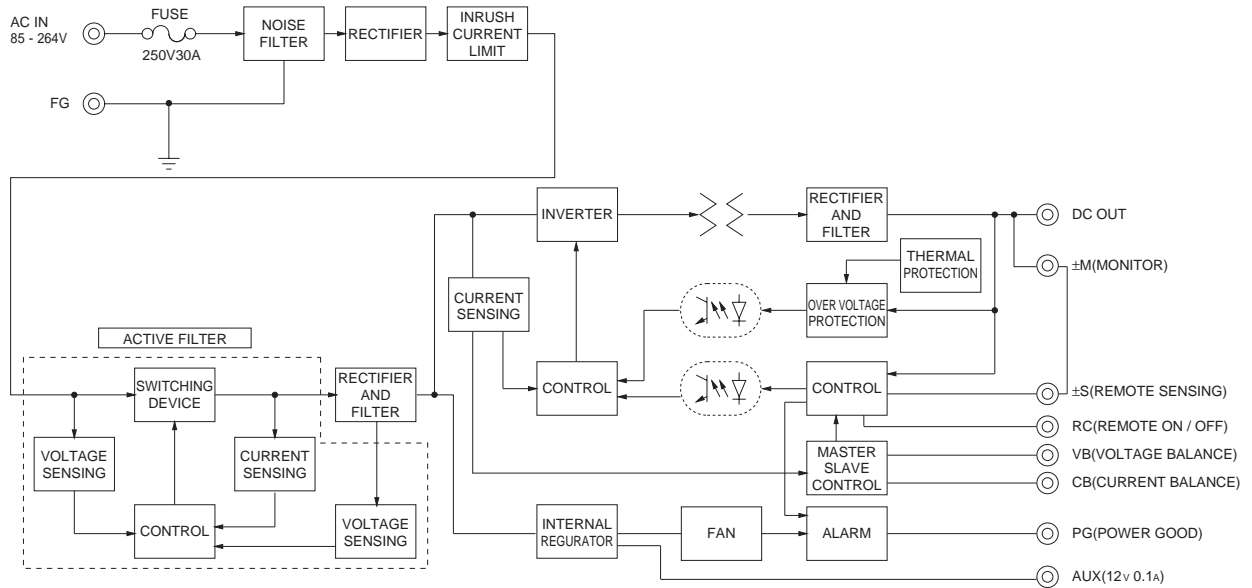

External view

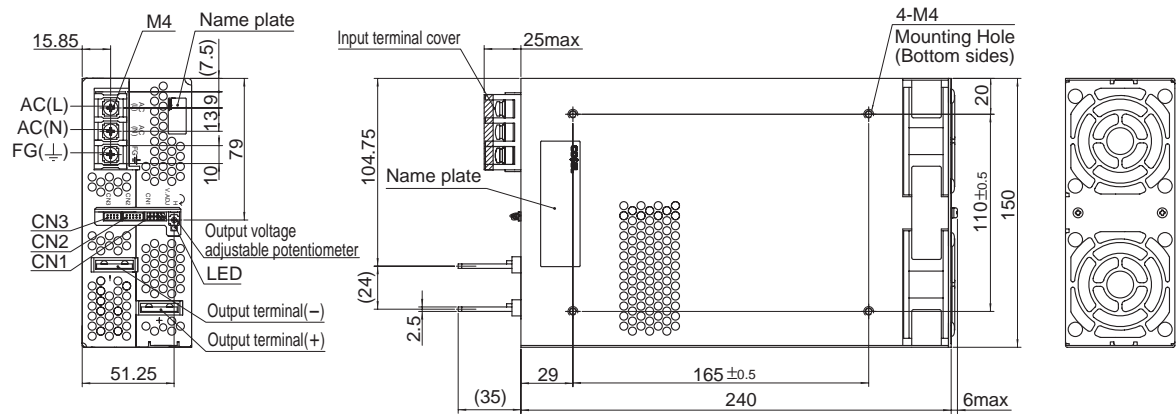

- ※ Tolerance : ±1
- ※ Mass : 2.2kg or less
- ※ PCB Material/thickness : FR-4 / 1.6mm
- ※ Chassis material : Aluminum
- ※ Dimensions in mm
- ※ Mounting torque : 1.2N • m(12.8kgf • cm)max
- ※ Screw tightening torque : 1.6N • m(16.9kgf • cm)max
- ※ The housing for the remote sensing unused is mounted on CN1
- ※ Please connect earth to FG terminal on the unit.

X-ON Electronics

Largest Supplier of Electrical and Electronic Components

Click to view similar products for [Switching Power Supplies](#) category:

Click to view products by [Cosel](#) manufacturer:

Other Similar products are found below :

[70841011](#) [73-551-0005](#) [73-551-0048](#) [PS3E-B12F](#) [PS3E-E12F](#) [AAD600S-4-OP](#) [R22095](#) [KD0204](#) [9021](#) [LDIN100150](#) [LPM000-BBAR-01](#)
[LPX17S-C](#) [EVS57-10R6/R](#) [FP80](#) [FRV7000G](#) [22929](#) [PS3E-F12F](#) [CQM1IA121](#) [40370121900](#) [VI-PU22-EXX](#) [40370121910](#) [LDIN5075](#)
[LPM615-CHAS](#) [LPX140-C](#) [09-160CFG](#) [70841025](#) [VPX3000-CBL-DC](#) [VI-LUL-IU](#) [LPM000-BBAR-05](#) [LPM000-BBAR-08](#) [LPM124-](#)
[OUTA1-48](#) [LPM000-BBAR-07](#) [LPM109-OUTA1-10](#) [LPM616-CHAS](#) [08-30466-1055G](#) [08-30466-2175G](#) [08-30466-2125G](#) [DMB-EWG](#)
[TVQF-1219-18S](#) [6504-226-2101](#) [CQM1IPS01](#) [SP-300-5](#) [CQM1-IPS02](#) [VI-MUL-ES](#) [22829](#) [08-30466-0065G](#) [VI-RU031-EWWX](#) [08-30466-](#)
[0028G](#) [EP3000AC48INZ](#) [VP-C2104853](#)