

SUW1R5

SU W 1R5 12 12 B P

① ② ③ ④ ⑤ ⑥ ⑦



RoHS

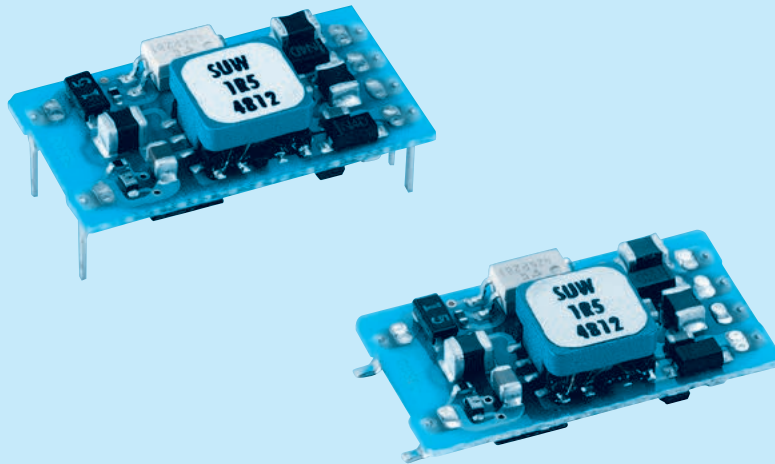

- ① Series name
- ② Dual output
- ③ Output wattage
- ④ Input voltage
- ⑤ Output voltage
- ⑥ Mounting type
B : SMD
C : DIP
- ⑦ Packing form
Blank: Plastic cover
P : Tray (SMD type)

| MODEL | SUW1R50512 | SUW1R50515 | SUW1R51212 | SUW1R51215 | SUW1R52412 | SUW1R52415 | SUW1R54812 | SUW1R54815 | |
|-----------------------|---------------|-------------|-------------|-------------|-------------|-------------|-------------|-------------|-------------|
| MAX OUTPUT WATTAGE[W] | 1.56 | 1.5 | 1.56 | 1.5 | 1.56 | 1.5 | 1.56 | 1.5 | |
| DC OUTPUT | VOLTAGE[V] *1 | ± 12 or +24 | ± 15 or +30 | ± 12 or +24 | ± 15 or +30 | ± 12 or +24 | ± 15 or +30 | ± 12 or +24 | ± 15 or +30 |
| | CURRENT[A] | 0.065 | 0.05 | 0.065 | 0.05 | 0.065 | 0.05 | 0.065 | 0.05 |

SPECIFICATIONS

| | MODEL | SUW1R50512 | SUW1R50515 | SUW1R51212 | SUW1R51215 | SUW1R52412 | SUW1R52415 | SUW1R54812 | SUW1R54815 | |
|---------------------------------|--|--|---------------|---------------|---------------|---------------|---------------|---------------|------------|--------|
| INPUT | VOLTAGE[V] | DC4.5 - 9 | | DC9 - 18 | | DC18 - 36 | | DC36 - 76 | | |
| | CURRENT[A] *2 | 0.433typ | 0.417typ | 0.173typ | 0.167typ | 0.087typ | 0.083typ | 0.043typ | 0.042typ | |
| | EFFICIENCY[%] *2 | 72typ | 72typ | 75typ | 75typ | 75typ | 75typ | 75typ | 75typ | |
| OUTPUT | VOLTAGE[V] | ± 12(+24) | ± 15(+30) | ± 12(+24) | ± 15(+30) | ± 12(+24) | ± 15(+30) | ± 12(+24) | ± 15(+30) | |
| | CURRENT[A] | 0.065 | 0.05 | 0.065 | 0.05 | 0.065 | 0.05 | 0.065 | 0.05 | |
| | LINE REGULATION[mV] | 60max | 75max | 60max | 75max | 60max | 75max | 60max | 75max | |
| | LOAD REGULATION[mV] | 600max | 750max | 600max | 750max | 600max | 750max | 600max | 750max | |
| | RIPPLE[mVp-p] | -20 to +55°C *3 | 120max | 120max | 120max | 120max | 120max | 120max | 120max | 120max |
| | | -40 to -20°C *3 | 150max | 150max | 150max | 150max | 150max | 150max | 150max | 150max |
| | RIPPLE NOISE[mVp-p] | -20 to +55°C *3 | 150max | 150max | 150max | 150max | 150max | 150max | 150max | 150max |
| | | -40 to -20°C *3 | 200max | 200max | 200max | 200max | 200max | 200max | 200max | 200max |
| | TEMPERATURE REGULATION[mV] | -20 to +55°C | 150max | 180max | 150max | 180max | 150max | 180max | 150max | 180max |
| | | -40 to +55°C | 240max | 290max | 240max | 290max | 240max | 290max | 240max | 290max |
| DRIFT[mV] *4 | 50max | 60max | 50max | 60max | 50max | 60max | 50max | 60max | | |
| START-UP TIME[ms] | 20max (Minimum input, Io=100%) | | | | | | | | | |
| OUTPUT VOLTAGE ADJUSTMENT RANGE | Fixed (TRM pin open) ±5% adjustable by external VR | | | | | | | | | |
| OUTPUT VOLTAGE SETTING[V] (±5%) | 11.40 - 12.60 | 14.25 - 15.75 | 11.40 - 12.60 | 14.25 - 15.75 | 11.40 - 12.60 | 14.25 - 15.75 | 11.40 - 12.60 | 14.25 - 15.75 | | |
| PROTECTION CIRCUIT AND OTHERS | OVERCURRENT PROTECTION | Works over 105% of rating and recovers automatically | | | | | | | | |
| ISOLATION | INPUT-OUTPUT | AC500V 1minute, Cutoff current = 10mA, DC500V 50MΩ min (20±15°C) | | | | | | | | |
| ENVIRONMENT | OPERATING TEMP., HUMID. AND ALTITUDE | -40 to +85°C, 20 - 95%RH (Non condensing) (Required Derating), 3,000m (10,000feet) max | | | | | | | | |
| | STORAGE TEMP., HUMID. AND ALTITUDE | -40 to +100°C, 20 - 95%RH (Non condensing), 9,000m (30,000feet) max | | | | | | | | |
| | VIBRATION | 10 - 55Hz, 98.0m/s ² (10G), 3minutes period, 60minutes each along X, Y and Z axis | | | | | | | | |
| | IMPACT | 490.3m/s ² (50G), 11ms, once each along X, Y and Z axis | | | | | | | | |
| SAFETY | AGENCY APPROVALS | UL60950-1, C-UL, EN60950-1 | | | | | | | | |
| OTHERS | CASE SIZE/WEIGHT | 21.4 × 6.5 × 12.2mm [0.84 × 0.26 × 0.48 inches] (W × H × D) / 2g max | | | | | | | | |
| | COOLING METHOD | Convection/Forced air | | | | | | | | |

*1 Output pins can be connected in series to make a 24V/30V output.

*2 Rated input 5V, 12V, 24V or 48V DC Io=100%

*3 Ripple and Ripple Noise is measured by using measuring board with capacitor with in 25mm from output pin terminals.

*4 Drift is the change in DC output for an eight hour period after a half-hour warm-up at 25°C.

* Parallel operation with other model is not possible.

SUW3

SU W 3 12 12 B P - □
 ① ② ③ ④ ⑤ ⑥ ⑦ ⑧

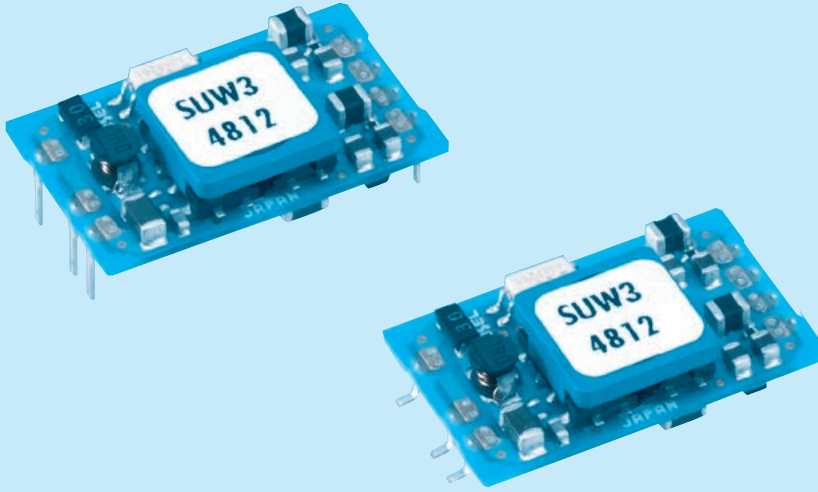

- ① Series name
- ② Dual output
- ③ Output wattage
- ④ Input voltage
- ⑤ Output voltage
- ⑥ Mounting type
B : SMD
C : DIP
- ⑦ Packing form
Blank: Plastic cover
P : Tray (SMD type)
- ⑧ Optional
G : Capacitor between Input and Output is removed.

| MODEL | SUW30512 | SUW30515 | SUW31212 | SUW31215 | SUW32412 | SUW32415 | SUW34812 | SUW34815 | |
|-----------------------|---------------|------------|------------|------------|------------|------------|------------|------------|------------|
| MAX OUTPUT WATTAGE[W] | 3.12 | 3 | 3.12 | 3 | 3.12 | 3 | 3.12 | 3 | |
| DC OUTPUT | VOLTAGE[V] *1 | ±12 or +24 | ±15 or +30 | ±12 or +24 | ±15 or +30 | ±12 or +24 | ±15 or +30 | ±12 or +24 | ±15 or +30 |
| | CURRENT[A] | 0.13 | 0.1 | 0.13 | 0.1 | 0.13 | 0.1 | 0.13 | 0.1 |

SPECIFICATIONS

| | MODEL | SUW30512 | SUW30515 | SUW31212 | SUW31215 | SUW32412 | SUW32415 | SUW34812 | SUW34815 | |
|---------------------------------|--|--|---------------|---------------|---------------|---------------|---------------|---------------|----------|--------|
| INPUT | VOLTAGE[V] | DC4.5 - 9 | | DC9 - 18 | | DC18 - 36 | | DC36 - 76 | | |
| | CURRENT[A] *2 | 0.822typ | 0.790typ | 0.334typ | 0.321typ | 0.167typ | 0.161typ | 0.084typ | 0.081typ | |
| | EFFICIENCY[%] *2 | 76typ | 76typ | 78typ | 78typ | 78typ | 78typ | 78typ | 78typ | |
| OUTPUT | VOLTAGE[V] | ±12(+24) | ±15(+30) | ±12(+24) | ±15(+30) | ±12(+24) | ±15(+30) | ±12(+24) | ±15(+30) | |
| | CURRENT[A] | 0.13 | 0.1 | 0.13 | 0.1 | 0.13 | 0.1 | 0.13 | 0.1 | |
| | LINE REGULATION[mV] | 60max | 75max | 60max | 75max | 60max | 75max | 60max | 75max | |
| | LOAD REGULATION[mV] | 600max | 750max | 600max | 750max | 600max | 750max | 600max | 750max | |
| | RIPPLE[mVp-p] | -20 to +55°C *3 | 120max | 120max | 120max | 120max | 120max | 120max | 120max | 120max |
| | | -40 to -20°C *3 | 150max | 150max | 150max | 150max | 150max | 150max | 150max | 150max |
| | RIPPLE NOISE[mVp-p] | -20 to +55°C *3 | 150max | 150max | 150max | 150max | 150max | 150max | 150max | 150max |
| | | -40 to -20°C *3 | 200max | 200max | 200max | 200max | 200max | 200max | 200max | 200max |
| | TEMPERATURE REGULATION[mV] | -20 to +55°C | 150max | 180max | 150max | 180max | 150max | 180max | 150max | 180max |
| | -40 to +55°C | 240max | 290max | 240max | 290max | 240max | 290max | 240max | 290max | |
| DRIFT[mV] *4 | 50max | 60max | 50max | 60max | 50max | 60max | 50max | 60max | | |
| START-UP TIME[ms] | 20max (Minimum input, Io=100%) | | | | | | | | | |
| OUTPUT VOLTAGE ADJUSTMENT RANGE | Fixed (TRM pin open) ±5% adjustable by external VR | | | | | | | | | |
| OUTPUT VOLTAGE SETTING[V] (±5%) | 11.40 - 12.60 | 14.25 - 15.75 | 11.40 - 12.60 | 14.25 - 15.75 | 11.40 - 12.60 | 14.25 - 15.75 | 11.40 - 12.60 | 14.25 - 15.75 | | |
| PROTECTION CIRCUIT AND OTHERS | OVERCURRENT PROTECTION | Works over 105% of rating and recovers automatically | | | | | | | | |
| | REMOTE ON/OFF | Provided (Negative logic L : ON, H : OFF) | | | | | | | | |
| ISOLATION | INPUT-OUTPUT | AC500V 1minute, Cutoff current = 10mA, DC500V 50MΩ min (20±15°C) | | | | | | | | |
| ENVIRONMENT | OPERATING TEMP., HUMID. AND ALTITUDE | -40 to +85°C, 20 - 95%RH (Non condensing) (Required Derating), 3,000m (10,000feet) max | | | | | | | | |
| | STORAGE TEMP., HUMID. AND ALTITUDE | -40 to +100°C, 20 - 95%RH (Non condensing), 9,000m (30,000feet) max | | | | | | | | |
| | VIBRATION | 10 - 55Hz, 98.0m/s ² (10G), 3minutes period, 60minutes each along X, Y and Z axis | | | | | | | | |
| | IMPACT | 490.3m/s ² (50G), 11ms, once each along X, Y and Z axis | | | | | | | | |
| SAFETY | AGENCY APPROVALS | UL60950-1, C-UL, EN60950-1 | | | | | | | | |
| OTHERS | CASE SIZE/WEIGHT | 24 × 6.5 × 15.1mm [0.94 × 0.26 × 0.59 inches] (W × H × D) / 3g max | | | | | | | | |
| | COOLING METHOD | Convection/Forced air | | | | | | | | |

*1 Output pins can be connected in series to make a 24V/30V output.
 *2 Rated input 5V, 12V, 24V or 48V DC Io=100%
 *3 Ripple and Ripple Noise is measured by using measuring board with capacitor with in 25mm from output pin terminals.
 *4 Drift is the change in DC output for an eight hour period after a half-hour warm-up at 25°C.
 * Parallel operation with other model is not possible.

External view

1.SMD(type B)

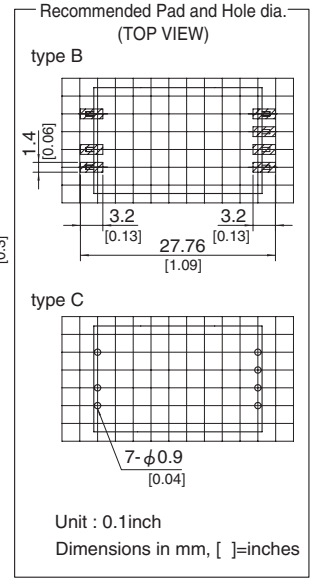
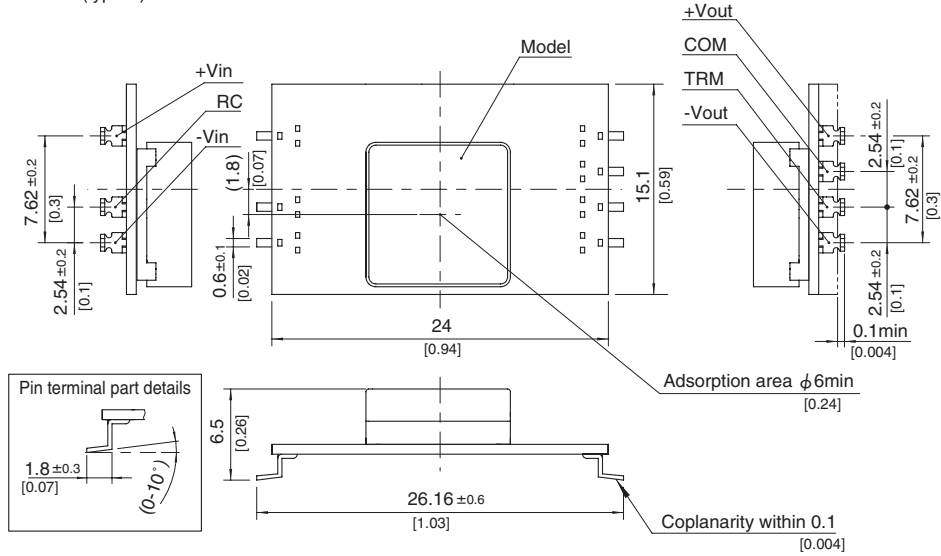

2.DIP(type C)

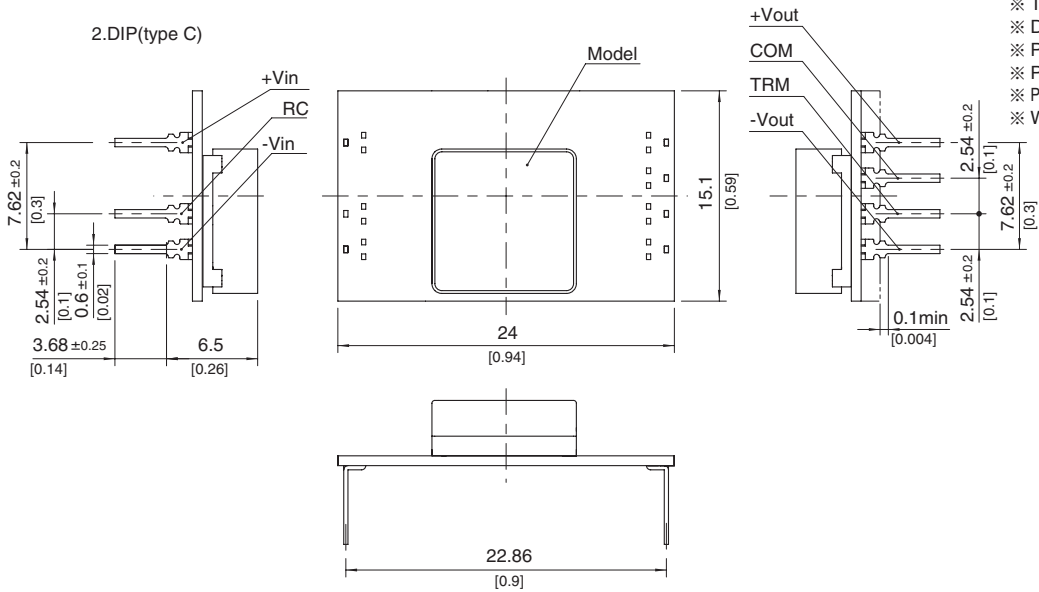

- ※ Tolerance ±0.5 [±0.02]
- ※ Dimensions in mm, []=inches
- ※ Pin terminal thickness : 0.3±0.1 [0.012]
- ※ Pin terminal material : Copper alloy
- ※ Plating treatment of terminal : Lead free plating
- ※ Weight : 3g max

SUW6

SU W 6 12 12 B P - □

① ② ③ ④ ⑤ ⑥ ⑦ ⑧

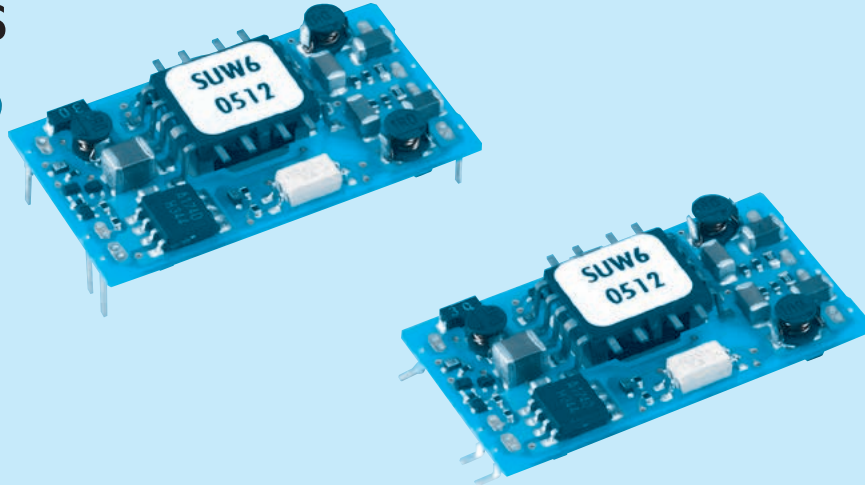

- ① Series name
- ② Dual output
- ③ Output wattage
- ④ Input voltage
- ⑤ Output voltage
- ⑥ Mounting type
B : SMD
C : DIP
- ⑦ Packing form
Blank: Plastic cover
P : Tray (SMD type)
- ⑧ Optional
G : Capacitor between
Input and Output is
removed.

| MODEL | SUW60512 | SUW60515 | SUW61212 | SUW61215 | SUW62412 | SUW62415 | SUW64812 | SUW64815 | |
|-----------------------|---------------|------------|------------|------------|------------|------------|------------|------------|------------|
| MAX OUTPUT WATTAGE[W] | 6 | 6 | 6 | 6 | 6 | 6 | 6 | 6 | |
| DC OUTPUT | VOLTAGE[V] *1 | ±12 or +24 | ±15 or +30 | ±12 or +24 | ±15 or +30 | ±12 or +24 | ±15 or +30 | ±12 or +24 | ±15 or +30 |
| | CURRENT[A] | 0.25 | 0.2 | 0.25 | 0.2 | 0.25 | 0.2 | 0.25 | 0.2 |

SPECIFICATIONS

| | MODEL | SUW60512 | SUW60515 | SUW61212 | SUW61215 | SUW62412 | SUW62415 | SUW64812 | SUW64815 | |
|---------------------------------|--|--|---------------|---------------|---------------|---------------|---------------|---------------|---------------|--------|
| INPUT | VOLTAGE[V] | DC4.5 - 9 | | DC9 - 18 | | DC18 - 36 | | DC36 - 76 | | |
| | CURRENT[A] *2 | 1.538typ | 1.538typ | 0.588typ | 0.588typ | 0.291typ | 0.291typ | 0.145typ | 0.145typ | |
| | EFFICIENCY[%] *2 | 78typ | 78typ | 85typ | 85typ | 86typ | 86typ | 86typ | 86typ | |
| OUTPUT | VOLTAGE[V] | ±12(+24) | ±15(+30) | ±12(+24) | ±15(+30) | ±12(+24) | ±15(+30) | ±12(+24) | ±15(+30) | |
| | CURRENT[A] | 0.25 | 0.2 | 0.25 | 0.2 | 0.25 | 0.2 | 0.25 | 0.2 | |
| | LINE REGULATION[mV] | 60max | 75max | 60max | 75max | 60max | 75max | 60max | 75max | |
| | LOAD REGULATION[mV] | 600max | 750max | 600max | 750max | 600max | 750max | 600max | 750max | |
| | RIPPLE[mVp-p] | -20 to +55°C *3 | 120max | 120max | 120max | 120max | 120max | 120max | 120max | 120max |
| | | -40 to -20°C *3 | 150max | 150max | 150max | 150max | 150max | 150max | 150max | 150max |
| | RIPPLE NOISE[mVp-p] | -20 to +55°C *3 | 150max | 150max | 150max | 150max | 150max | 150max | 150max | 150max |
| | | -40 to -20°C *3 | 200max | 200max | 200max | 200max | 200max | 200max | 200max | 200max |
| | TEMPERATURE REGULATION[mV] | -20 to +55°C | 150max | 180max | 150max | 180max | 150max | 180max | 150max | 180max |
| | | -40 to +55°C | 240max | 290max | 240max | 290max | 240max | 290max | 240max | 290max |
| DRIFT[mV] *4 | 50max | 60max | 50max | 60max | 50max | 60max | 50max | 60max | | |
| START-UP TIME[ms] | 20max (Minimum input, Io=100%) | | | | | | | | | |
| OUTPUT VOLTAGE ADJUSTMENT RANGE | Fixed (TRM pin open) ±5% adjustable by external VR | | | | | | | | | |
| OUTPUT VOLTAGE SETTING[V] (±5%) | 11.40 - 12.60 | 14.25 - 15.75 | 11.40 - 12.60 | 14.25 - 15.75 | 11.40 - 12.60 | 14.25 - 15.75 | 11.40 - 12.60 | 14.25 - 15.75 | 11.40 - 12.60 | |
| PROTECTION CIRCUIT AND OTHERS | OVERCURRENT PROTECTION | Works over 105% of rating and recovers automatically | | | | | | | | |
| | REMOTE ON/OFF | Provided (Negative logic L : ON, H : OFF) | | | | | | | | |
| ISOLATION | INPUT-OUTPUT | AC500V 1minute, Cutoff current = 10mA, DC500V 50MΩ min (20±15°C) | | | | | | | | |
| ENVIRONMENT | OPERATING TEMP., HUMID. AND ALTITUDE | -40 to +85°C, 20 - 95%RH (Non condensing) (Required Derating), 3,000m (10,000feet) max | | | | | | | | |
| | STORAGE TEMP., HUMID. AND ALTITUDE | -40 to +100°C, 20 - 95%RH (Non condensing), 9,000m (30,000feet) max | | | | | | | | |
| | VIBRATION | 10 - 55Hz, 98.0m/s ² (10G), 3minutes period, 60minutes each along X, Y and Z axis | | | | | | | | |
| | IMPACT | 490.3m/s ² (50G), 11ms, once each along X, Y and Z axis | | | | | | | | |
| SAFETY | AGENCY APPROVALS | UL60950-1, C-UL, EN60950-1 | | | | | | | | |
| OTHERS | CASE SIZE/WEIGHT | 31.6 × 6.5 × 18.1mm [1.24 × 0.26 × 0.71 inches] (W × H × D) / 4g max | | | | | | | | |
| | COOLING METHOD | Convection/Forced air | | | | | | | | |

*1 Output pins can be connected in series to make a 24V/30V output.
 *2 Rated input 5V, 12V, 24V or 48V DC Io=100%
 *3 Ripple and Ripple Noise is measured by using measuring board with capacitor with in 25mm from output pin terminals.
 *4 Drift is the change in DC output for an eight hour period after a half-hour warm-up at 25°C.
 * Parallel operation with other model is not possible.

External view

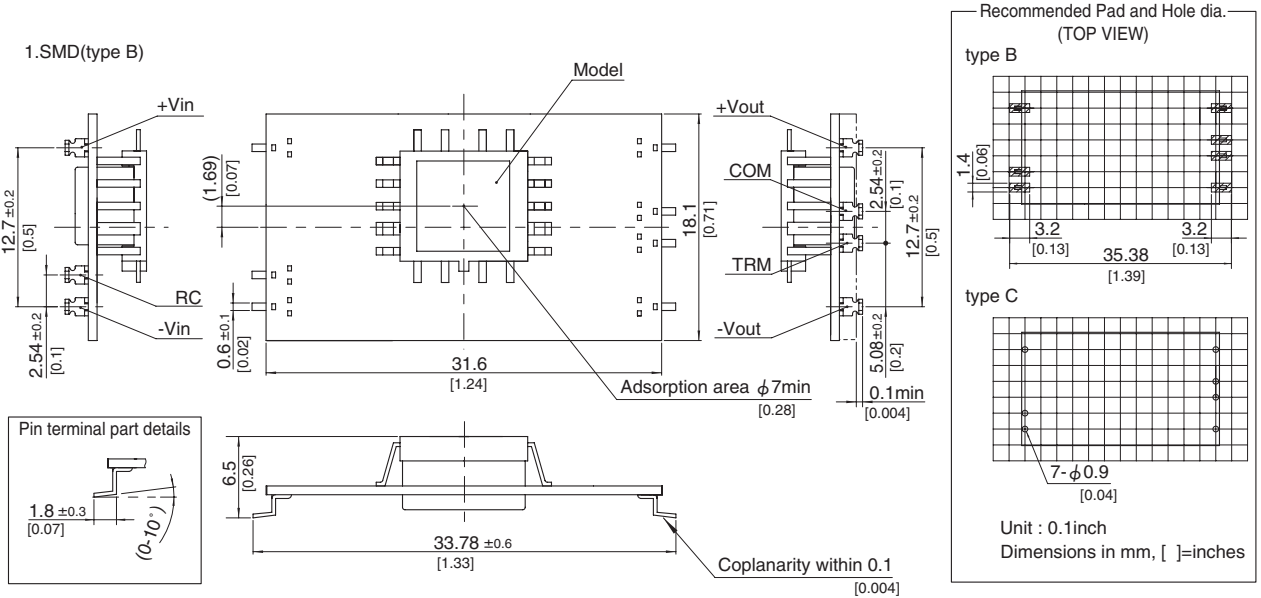

- ※ Tolerance ± 0.5 [± 0.02]
- ※ Dimensions in mm, []=inches
- ※ Pin terminal thickness : 0.3 ± 0.1 [0.012]
- ※ Pin terminal material : Copper alloy
- ※ Plating treatment of terminal : Lead free plating
- ※ Weight : 4g max

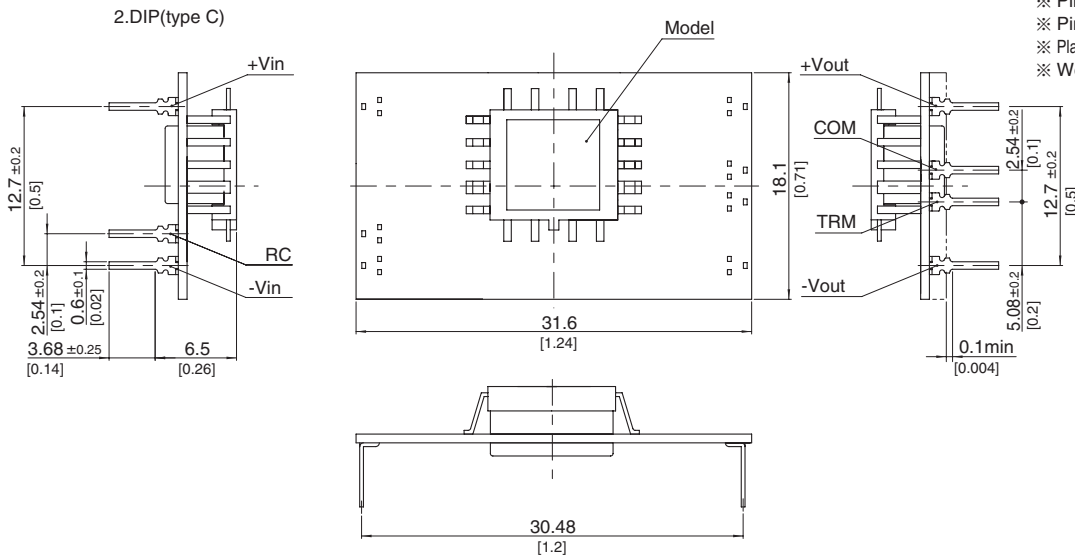

SUW10

SU W 10 12 12 B P - □

① ② ③ ④ ⑤ ⑥ ⑦ ⑧



RoHS

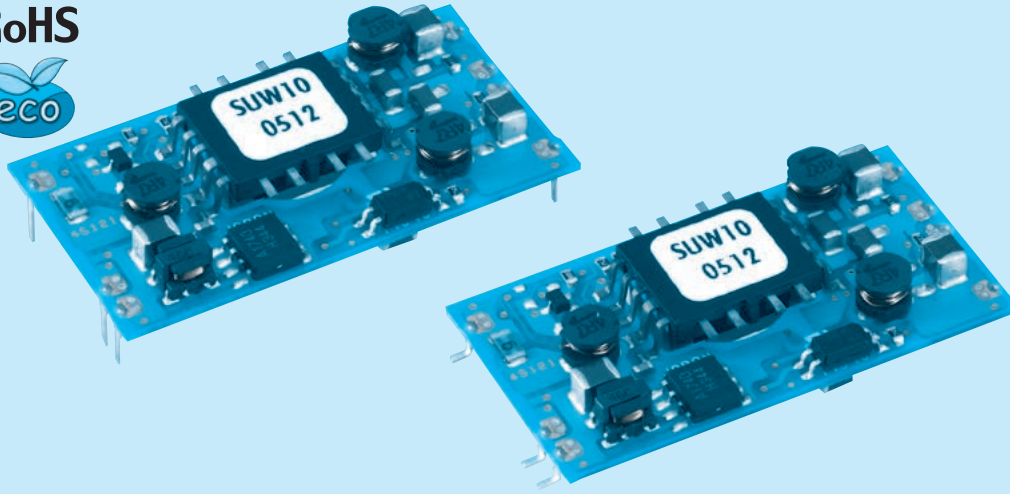

- ① Series name
- ② Dual output
- ③ Output wattage
- ④ Input voltage
- ⑤ Output voltage
- ⑥ Mounting type
B : SMD
C : DIP
- ⑦ Packing form
Blank: Plastic cover
P : Tray(SMD type)
- ⑧ Optional
G : Capacitor between Input and Output is removed.

| MODEL | SUW100512 | SUW100515 | SUW101212 | SUW101215 | SUW102412 | SUW102415 | SUW104812 | SUW104815 | |
|-----------------------|---------------|------------|------------|------------|------------|------------|------------|------------|------------|
| MAX OUTPUT WATTAGE[W] | 10.8 | 10.5 | 10.8 | 10.5 | 10.8 | 10.5 | 10.8 | 10.5 | |
| DC OUTPUT | VOLTAGE[V] *1 | ±12 or +24 | ±15 or +30 | ±12 or +24 | ±15 or +30 | ±12 or +24 | ±15 or +30 | ±12 or +24 | ±15 or +30 |
| | CURRENT[A] | 0.45 | 0.35 | 0.45 | 0.35 | 0.45 | 0.35 | 0.45 | 0.35 |

SPECIFICATIONS

| | MODEL | SUW100512 | SUW100515 | SUW101212 | SUW101215 | SUW102412 | SUW102415 | SUW104812 | SUW104815 | |
|---------------------------------|--|--|---------------|---------------|---------------|---------------|---------------|---------------|-----------|--------|
| INPUT | VOLTAGE[V] | DC4.5 - 9 | | DC9 - 18 | | DC18 - 36 | | DC36 - 76 | | |
| | CURRENT[A] *2 | 2.51typ | 2.44typ | 1.05typ | 1.02typ | 0.523typ | 0.509typ | 0.262typ | 0.254typ | |
| | EFFICIENCY[%] *2 | 86typ | 86typ | 86typ | 86typ | 86typ | 86typ | 86typ | 86typ | |
| OUTPUT | VOLTAGE[V] | ±12(+24) | ±15(+30) | ±12(+24) | ±15(+30) | ±12(+24) | ±15(+30) | ±12(+24) | ±15(+30) | |
| | CURRENT[A] | 0.45 | 0.35 | 0.45 | 0.35 | 0.45 | 0.35 | 0.45 | 0.35 | |
| | LINE REGULATION[mV] | 60max | 75max | 60max | 75max | 60max | 75max | 60max | 75max | |
| | LOAD REGULATION[mV] | 600max | 750max | 600max | 750max | 600max | 750max | 600max | 750max | |
| | RIPPLE[mVp-p] | -20 to +55°C *3 | 120max | 120max | 120max | 120max | 120max | 120max | 120max | 120max |
| | | -40 to -20°C *3 | 150max | 150max | 150max | 150max | 150max | 150max | 150max | 150max |
| | RIPPLE NOISE[mVp-p] | -20 to +55°C *3 | 150max | 150max | 150max | 150max | 150max | 150max | 150max | 150max |
| | | -40 to -20°C *3 | 200max | 200max | 200max | 200max | 200max | 200max | 200max | 200max |
| | TEMPERATURE REGULATION[mV] | -20 to +55°C | 150max | 180max | 150max | 180max | 150max | 180max | 150max | 180max |
| | | -40 to +55°C | 240max | 290max | 240max | 290max | 240max | 290max | 240max | 290max |
| DRIFT[mV] *4 | 50max | 60max | 50max | 60max | 50max | 60max | 50max | 60max | | |
| START-UP TIME[ms] | 20max (Minimum input, Io=100%) | | | | | | | | | |
| OUTPUT VOLTAGE ADJUSTMENT RANGE | Fixed (TRM pin open) ±5% adjustable by external VR | | | | | | | | | |
| OUTPUT VOLTAGE SETTING[V] (±5%) | 11.40 - 12.60 | 14.25 - 15.75 | 11.40 - 12.60 | 14.25 - 15.75 | 11.40 - 12.60 | 14.25 - 15.75 | 11.40 - 12.60 | 14.25 - 15.75 | | |
| PROTECTION CIRCUIT AND OTHERS | OVERCURRENT PROTECTION | Works over 105% of rating and recovers automatically | | | | | | | | |
| | REMOTE ON/OFF | Provided (Negative logic L : ON, H : OFF) | | | | | | | | |
| ISOLATION | INPUT-OUTPUT | AC500V 1minute, Cutoff current = 10mA, DC500V 50MΩ min (20±15°C) | | | | | | | | |
| ENVIRONMENT | OPERATING TEMP., HUMID. AND ALTITUDE | -40 to +85°C, 20 - 95%RH (Non condensing) (Required Derating), 3,000m (10,000feet) max | | | | | | | | |
| | STORAGE TEMP., HUMID. AND ALTITUDE | -40 to +100°C, 20 - 95%RH (Non condensing), 9,000m (30,000feet) max | | | | | | | | |
| | VIBRATION | 10 - 55Hz, 98.0m/s ² (10G), 3minutes period, 60minutes each along X, Y and Z axis | | | | | | | | |
| | IMPACT | 490.3m/s ² (50G), 11ms, once each along X, Y and Z axis | | | | | | | | |
| SAFETY | AGENCY APPROVALS | UL60950-1, C-UL, EN60950-1 | | | | | | | | |
| OTHERS | CASE SIZE/WEIGHT | 39.2 × 6.5 × 21.0mm [1.54 × 0.26 × 0.83 inches] (W × H × D) / 6g max | | | | | | | | |
| | COOLING METHOD | Convection/Forced air | | | | | | | | |

*1 Output pins can be connected in series to make a 24V/30V output.
 *2 Rated input 5V, 12V, 24V or 48V DC Io=100%
 *3 Ripple and Ripple Noise is measured by using measuring board with capacitor with in 25mm from output pin terminals.
 *4 Drift is the change in DC output for an eight hour period after a half-hour warm-up at 25°C.
 * Parallel operation with other model is not possible.

External view

1.SMD(type B)

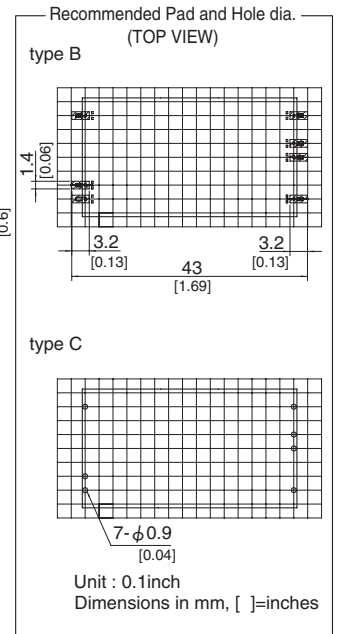
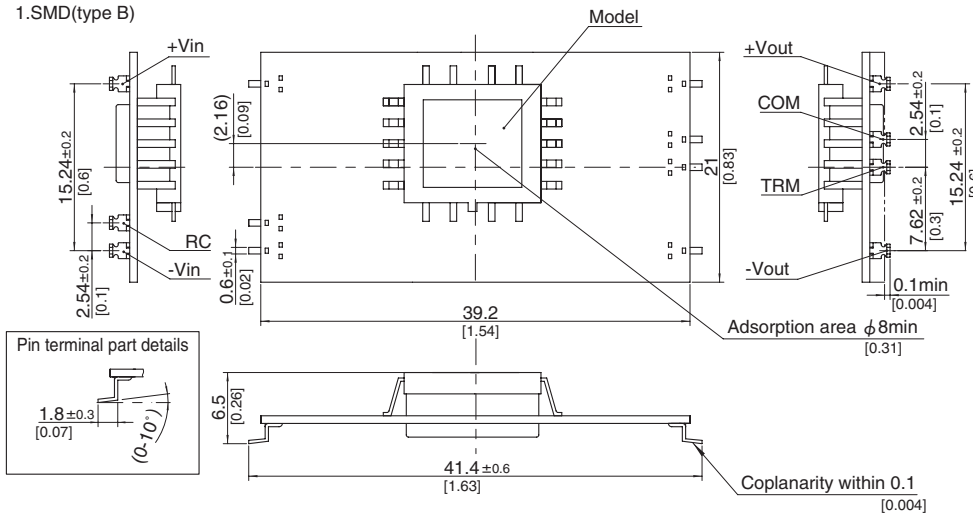

2.DIP(type C)

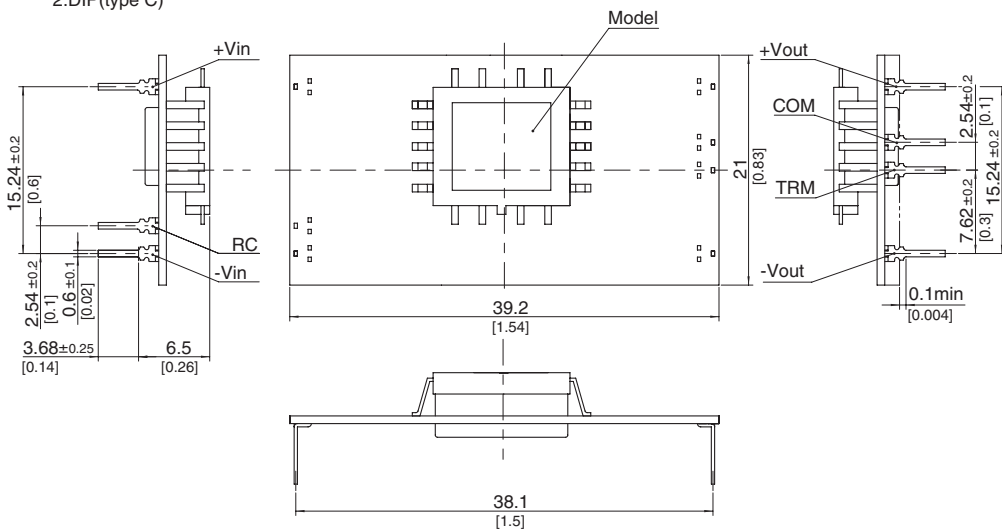

- ※ Tolerance ±0.5 [±0.02]
- ※ Dimensions in mm, []=inches
- ※ Pin terminal thickness : 0.3±0.1 [0.012]
- ※ Pin terminal material : Copper alloy
- ※ Plating treatment of terminal : Lead free plating
- ※ Weight : 6g max

X-ON Electronics

Largest Supplier of Electrical and Electronic Components

Click to view similar products for [Isolated DC/DC Converters](#) category:

Click to view products by [Cosel](#) manufacturer:

Other Similar products are found below :

[ESM6D044440C05AAQ](#) [FMD15.24G](#) [PSL486-7LR](#) [Q48T30020-NBB0](#) [JAHW100Y1](#) [SPB05C-12](#) [SQ24S15033-PS0S](#) [18952](#) [19-130041](#)
[CE-1003](#) [CE-1004](#) [GQ2541-7R](#) [RDS180245](#) [MAU228](#) [J80-0041NL](#) [DFC15U48D15](#) [XGS-0512](#) [XGS-1205](#) [XGS-1212](#) [XGS-2412](#) [XGS-2415](#) [XKS-1215](#) [06322](#) [NCT1000N040R050B](#) [SPB05B-15](#) [SPB05C-15](#) [L-DA20](#) [DCG40-5G](#) [QME48T40033-PGB0](#) [XKS-2415](#) [XKS-2412](#)
[XKS-1212](#) [XKS-1205](#) [XKS-0515](#) [XKS-0505](#) [XGS-2405](#) [XGS-1215](#) [XGS-0515](#) [PS9Z-6RM4](#) [73-551-5038I](#) [AK1601-9RT](#) [VI-N61-CM](#) [VI-R5022-EXWW](#) [PSC128-7iR](#) [RPS8-350ATX-XE](#) [DAS1004812](#) [PQA30-D24-S24-DH](#) [VI-M5F-CQ](#) [VI-LN2-EW](#) [VI-PJW01-CZY](#)