

3.3V to 5V, RS-485 / RS-422 Transceiver with Auto-Direction Control

Features

- 3-V to 5.5-V Supply voltage
- Auto Direction Enables Driver Automatically on Transmission
- Half-duplex Transceiver
- Data Rates:
 - COS13487E: 500kbps (Slew-Rate Limiting)
 - COS13488E: 16Mbps
- Low Power Consumption:
 - Quiescent Current During Operation: 0.7mA
 - Standby Current < 5uA
- -7V to 12V Bus Common Mode Input Range
- Open, Short, and Idle Fail-safe Functions
- Bus Glitch-Free Power-Up and Power-Down
- Over Temperature Protection
- ESD Protection for RS-485 I/O Pins
 - ±15kV—Human Body Model
 - ±8kV—IEC 1000-4-2, Contact Discharge
 - ±15kV—IEC 1000-4-2, Air-Gap Discharge
- 1/8-Unit Load, Allow Up to 256 Transceivers on the bus
- Small Packaging: SOP8/MSOP8/DFN8

Applications

- Isolated RS-485 Interfaces
- Power Inverters
- Motor Control
- Industrial Automation
- Battery-Powered Applications

General Description

The COS13487E and COS13488E are low power differential bus/line transceivers with fail-safe and hot-swap features designed for multi-point data transmission standard and RS485 applications. They operate from a single 3 to 5.5V supply and also meets the requirements of RS422.

The COS13487E/COS13488E family feature auto-directional control, where the driver input is used in conjunction with the driver-enable signal to drive the differential bus. This architecture makes the devices ideal for isolated RS-485 applications.

The COS13487E allow error-free transmission up to 500kbps. The COS13488E driving slew rate is not limited, allowing transmit speeds up to 16Mbps. The devices offer significant power saving without sacrificing ruggedness against overload or ESD damage. It is available in 8-lead plastic SOP8, MSOP8, and DFN3x3-8, and is specified for operation from -40°C to +125°C ambient temperature.

Rev1.0

Copyright©2018 Cosine Nanoelectronics Inc. All rights reserved
The information provided here is believed to be accurate and reliable. Cosine Nanoelectronics assumes no liability for inaccuracies and omissions. Specifications described and contained here are subjected to change without notice on the purpose of improving the design and performance. All of this information described herein should not be implied or granted for any third party.

1. Pin Configuration and Functions

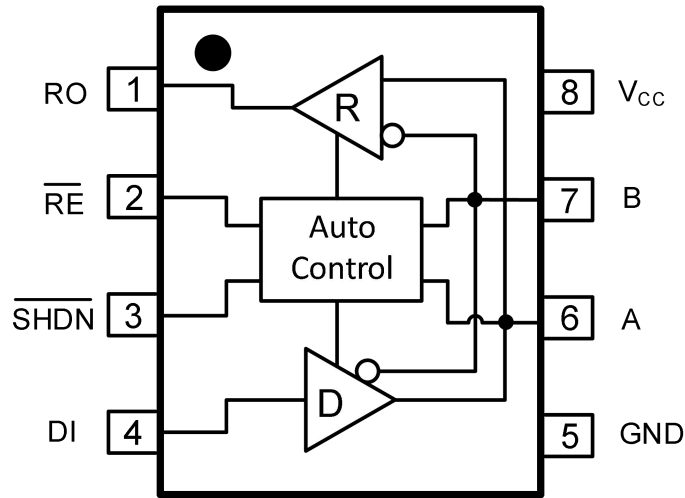

Figure 1 Pin Diagram

Pin Description

Pin	Name	Description
1	RO	Receiver output. When the receiver output is enabled (\overline{RE} low), then if $A > B$ by 200mV, RO will be high. If $A < B$ by 200mV, then RO will be low.
2	\overline{RE}	Receiver output enable. A low enables the receiver output, RO. A high input to let the auto-direction circuit control the receiver. \overline{RE} is a hot-swap input.
3	\overline{SHDN}	Shutdown. Drive \overline{SHDN} low to put the device in shutdown mode. Drive \overline{SHDN} high to let the device operate in normal operation.
4	DI	Driver input. Drive DI low to force non-inverting output low and inverting output high. Drive DI high to force non-inverting output high and inverting output low. DI is an input to the internal state machine that automatically enables and disables the driver.
5	GND	Ground
6	A	Non-inverting receiver input and non-inverting driver output
7	B	Inverting receiver input and inverting driver output
8	V _{CC}	Power Supply, 3-V to 5.5-V. Bypass V _{CC} to GND with a 0.1μF capacitor.

Driver Truth Table

Inputs			Outputs		Function
$\overline{\text{SHDN}}$	DI	A-B > V_{DT}	A	B	
H	L	X	L	H	Turn driver ON
H	H	True	Z	Z	Turn driver OFF
H	H	False	Z	Z	If driver was OFF, keep it OFF
H	H	False	H	L	If driver was ON, keep it ON
L	X	X	Z	Z	Shutdown

Receiver Truth Table

Inputs					Outputs
$\overline{\text{SHDN}}$	$\overline{\text{RE}}$	A-B	Driver State	Receiver State	R0
H	L	$\geq +0.2V$	X	ON	H
H	L	$\leq -0.2V$	X	ON	L
H	H	X	ON	OFF	Z
H	H	$\geq -0.2V$	OFF	ON	H
H	H	$\leq +0.2V$	OFF	ON	L
L	X	X	X	X	Z

Note: X = Don't care; Z = High impedance

2. Product Specification

2.1 Absolute Maximum Ratings ⁽¹⁾

Parameter	Min	Max	Unit
DC supply voltage, V_{CC}		+6	V
Control input voltages	-0.5	$V_{CC} + 0.5$	V
Driver input voltages	-0.5	$V_{CC} + 0.5$	V
Driver output voltage at A or B		± 16	V
Receiver input voltage		± 16	V
Receiver output voltage	-0.5	$V_{CC} + 0.5$	V
Operating junction temperature	-40	+135	$^{\circ}\text{C}$
Storage temperature	-55	+150	$^{\circ}\text{C}$

(1) Stresses exceeding the absolute maximum ratings may damage the device. The device may not function or be operable above the recommended operating conditions and stressing the parts to these levels is not recommended. In addition, extended exposure to stresses above the recommended operating conditions may affect device reliability. The absolute maximum ratings are stress ratings only.

2.2 Thermal Data

Parameter	Rating	Unit
Package Thermal Resistance, $R_{\theta JA}$ (Junction-to-ambient)	150 (SOP8) 206 (MSOP8) 57 (DFN8,3x3)	°C/W

2.3 ESD Rating

ESD Protection	Conditions	Rating	Unit
Bus terminals (A,B)	Air Gap Discharge IEC61000-4-2	± 15	kV
	Human Body Model	± 15	
All Other Pins	Human Body Model	± 2	

2.4 Recommended Operating Conditions

Parameter	Min.	Typ.	Max.	Unit
DC Supply voltage	3.0	5	5.5	V
Input voltage at any bus terminal	-7		12	V
Differential input voltage	-12		12	V
Differential load resistance	54	60		Ω
Data rate	0		500	kbps
Operating ambient temperature	-40		+85	°C
Operating junction temperature	-40		+125	°C

2.5 Electrical Characteristics

(Typical values are at $T_A=25\text{ }^\circ\text{C}$, $V_{CC}=5\text{V}$, unless otherwise noted.)

Parameter	Symbol	Conditions	Min.	Typ.	Max.	Unit
Driver Electrical Characteristics						
Differential driver output (no load)	V_{OD1}	$I_O = 0$	3	3.5		V
Differential driver output (with load)	V_{OD2}	$R_L = 50\ \Omega$ (RS422) $R_L = 27\ \Omega$ (RS485), (See Figure 2)	2.0 1.5	2.5 2.0		V
Change in magnitude of driver differential output voltage for complementary output states	ΔV_{OD}	$R_L = 27\ \Omega$ or $50\ \Omega$, (See Figure 2)	-0.2	0	0.2	V
Driver common-mode output voltage	V_{OC}	$R_L = 27\ \Omega$ or $50\ \Omega$, (See Figure 2)	1	$V_{CC}/2$	3	V
Change in magnitude of driver common-mode output voltage for complementary output states	ΔV_{OC}	$R_L = 27\ \Omega$ or $50\ \Omega$, (See Figure 2)			0.2	V
Driver disable threshold	V_{DT}		+0.6		+1.0	V
Driver short-circuit current	I_{OS}	$V_O = -7\text{V to }12\text{V}$, (See Figure 2)	-250		250	mA
Receiver Electrical Characteristics						
Receiver differential threshold voltage	V_{TH}	$V_{CM} = -7\text{V to }12\text{V}$	-200	-125	-50	mV
Receiver input hysteresis	ΔV_{TH}	$V_{CM} = 0\text{V}$		40		mV
Receiver input resistance	R_{IN}	$V_{CM} = -7\text{V to }12\text{V}$	96			k Ω
Input current (A, B)	I_{IN}	($V_{CC} = 0\text{V or }5\text{V}$, $V_{DE} = 0\text{V}$) $V_{IN} = 12\text{V}$ $V_{IN} = -7\text{V}$			+200 -200	μA
Receiver output high voltage	V_{OH}	$I_O = -4\text{mA}$	V_{CC} -0.4	V_{CC} -0.2		V
Receiver output low voltage	V_{OL}	$I_O = 4\text{mA}$		0.2	0.4	V
Receiver output short-circuit current	I_{OSR}	$V_O = 0\text{V to }V_{CC}$			± 60	mA
Tristate output leakage current	I_{OZR}	$V_O = 0.4\text{ to }2.4\text{V}$	-1		1	μA

Logic						
Logic Input high voltage	V_{IH}	DI, \overline{RE} , \overline{SHDN}	2.0			V
Logic Input low voltage	V_{IL}	DI, \overline{RE} , \overline{SHDN}			0.8	V
Logic Input current	I_{IN1}	DI, \overline{RE} , \overline{SHDN}			± 5	μA
Supply Current and Power Dissipation Characteristics						
Supply current (quiescent)	I_{CC}	$\overline{SHDN}=V_{CC}$, $\overline{RE}=0$, no Load		700	900	μA
Shutdown current	I_{SHDN}	$\overline{SHDN}=0$			10	μA
Average power dissipation	P_{AVG}	Unterminated; Data rate=500kbps, 50% duty cycle, $R_L = 150\Omega$, $C_L = 50pF$		75		mW
		RS-422; Data rate=500kbps, 50% duty cycle, $R_L = 50\Omega$, $C_L = 50pF$		150		
		RS-485; Data rate=500kbps, 50% duty cycle, $R_L = 27\Omega$, $C_L = 50pF$		215		
Thermal shutdown junction temperature	T_{SD}		150	170		$^{\circ}C$
Thermal shutdown hysteresis	T_{HYS}			30		$^{\circ}C$

2.6 Switching Characteristics - COS13487E

(Typical values are at $T_A=25^{\circ}C$, $V_{CC}=5V$, unless otherwise noted.)

Driver						
Propagation delay input to output, low to high	t_{PLH}	$R_{DIFF} = 54\Omega$, $C_{L1} = C_{L2} = 100pF$ (See Figure 3)		70	200	ns
Propagation delay input to output, high to low	t_{PHL}			70	200	ns
Output to output skew, $ t_{PHL} - t_{PLH} $	t_{SK}				15	ns
Differential output rise or fall time	t_r, t_f			100	250	400

Enable to output high	t_{PZH}	$C_L = 100\text{pF}$, $S_2 = \text{Closed}$ (See Figure 4 and Figure 5)		120	200	ns
Enable to output low	t_{PZL}	$C_L = 100\text{pF}$, $S_1 = \text{Closed}$ (See Figure 4 and Figure 5)		50	100	ns
Disable time from low	t_{PLZ}	$C_L = 15\text{pF}$, $S_1 = \text{Closed}$ (See Figure 4 and Figure 5)		120	200	ns
Disable time from high	t_{PHZ}	$C_L = 15\text{pF}$, $S_2 = \text{Closed}$ (See Figure 4 and Figure 5)		50	100	ns
Maximum data rate	f_{MAX}		500			kbps
Receiver						
Propagation delay input to output, low to high	t_{PLH}	$R_{DIFF} = 54\Omega$, $C_{L1} = C_{L2} = 100\text{pF}$, (See Figure 6)		25	50	ns
Propagation delay input to Output, high to low	t_{PHL}			25	50	ns
Output to output skew, $ t_{PHL} - t_{PLH} $	t_{SK}				5	ns
Enable to output high	t_{PZH}	$C_{RL} = 15\text{pF}$, $S_1 = \text{Closed}$ (See Figure 7 and Figure 8)		50	70	ns
Enable to output low	t_{PZL}	$C_{RL} = 15\text{pF}$, $S_2 = \text{Closed}$ (See Figure 7 and Figure 8)		10	50	ns
Disable time from low	t_{PLZ}	$C_{RL} = 15\text{pF}$, $S_1 = \text{Closed}$ (See Figure 7 and Figure 8)		15	40	ns
Disable time from high	t_{PHZ}	$C_{RL} = 15\text{pF}$, $S_2 = \text{Closed}$ (See Figure 7 and Figure 8)		20	50	ns
Maximum data rate	f_{MAX}		500			kbps

2.7 Switching Characteristics - COS13488E

(Typical values are at $T_A=25\text{ }^\circ\text{C}$, $V_{CC}=5\text{V}$, unless otherwise noted.)

Driver						
Propagation delay input to output, low to high	t_{PLH}	$R_{DIFF} = 54\Omega$, $C_{L1} = C_{L2} = 100\text{pF}$ (See Figure 3)			50	ns
Propagation delay input to output, high to low	t_{PHL}				50	ns
Output to output skew, $ t_{PHL} - t_{PLH} $	t_{SK}				5	ns
Differential output rise or fall time	t_r , t_f				15	ns

Enable to output high	t_{PZH}	$C_L = 100\text{pF}$, $S_2 = \text{Closed}$ (See Figure 4 and Figure 5)			70	ns
Enable to output low	t_{PZL}	$C_L = 100\text{pF}$, $S_1 = \text{Closed}$ (See Figure 4 and Figure 5)			70	ns
Disable time from low	t_{PLZ}	$C_L = 15\text{pF}$, $S_1 = \text{Closed}$ (See Figure 4 and Figure 5)			50	ns
Disable time from high	t_{PHZ}	$C_L = 15\text{pF}$, $S_2 = \text{Closed}$ (See Figure 4 and Figure 5)			50	ns
Maximum data rate	f_{MAX}		12			Mbps
Receiver						
Propagation delay input to output, low to high	t_{PLH}	$R_{DIFF} = 54\Omega$, $C_{L1} = C_{L2} = 100\text{pF}$, (See Figure 6)			75	ns
Propagation delay input to Output, high to low	t_{PHL}				75	ns
Output to output skew, $ t_{PHL} - t_{PLH} $	t_{SK}				5	ns
Enable to output high	t_{PZH}	$C_{RL} = 15\text{pF}$, $S_1 = \text{Closed}$ (See Figure 7 and Figure 8)			50	ns
Enable to output low	t_{PZL}	$C_{RL} = 15\text{pF}$, $S_2 = \text{Closed}$ (See Figure 7 and Figure 8)			50	ns
Disable time from low	t_{PLZ}	$C_{RL} = 15\text{pF}$, $S_1 = \text{Closed}$ (See Figure 7 and Figure 8)			25	ns
Disable time from high	t_{PHZ}	$C_{RL} = 15\text{pF}$, $S_2 = \text{Closed}$ (See Figure 7 and Figure 8)			25	ns
Maximum data rate	f_{MAX}		12			Mbps

3. Testing Circuits and Parameter Information

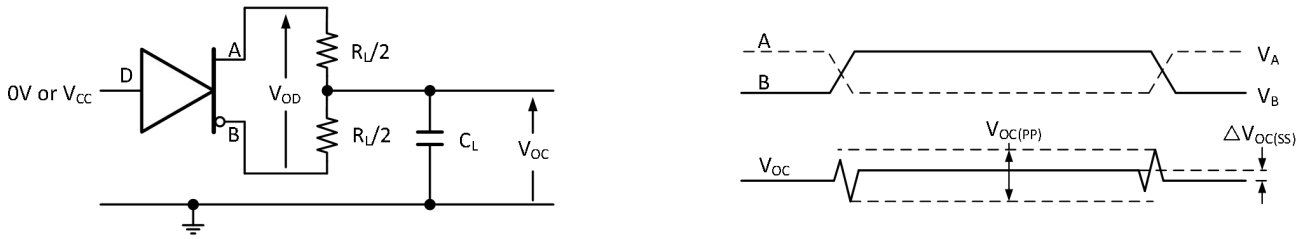

Figure 2. Measurement of Driver Differential and Common-Mode Output with RS-485 Load

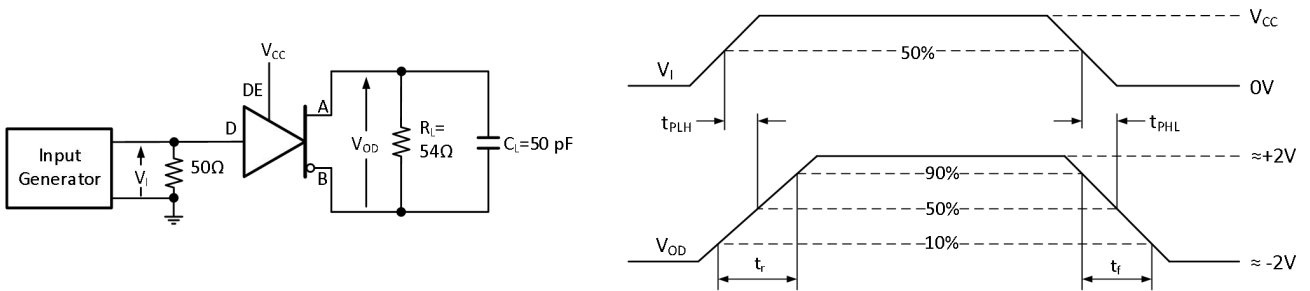

Figure 3. Measurement of Driver Differential Output Rise and Fall Times and Propagation Delays

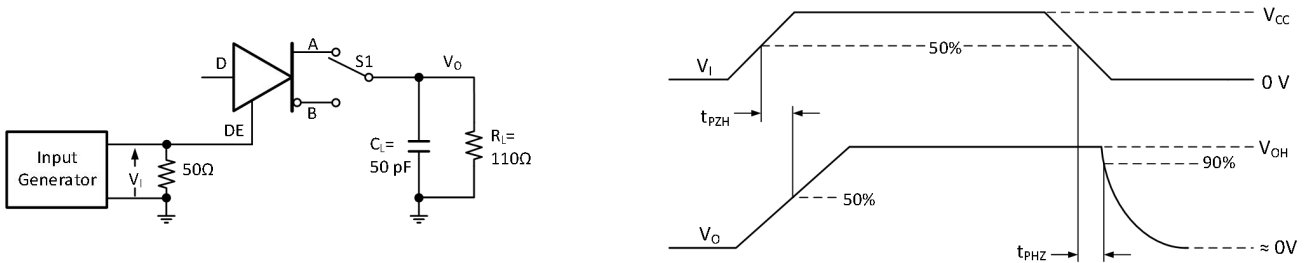

Figure 4. Measurement of Driver Enable and Disable Times with Active High Output and Pull-Down Load

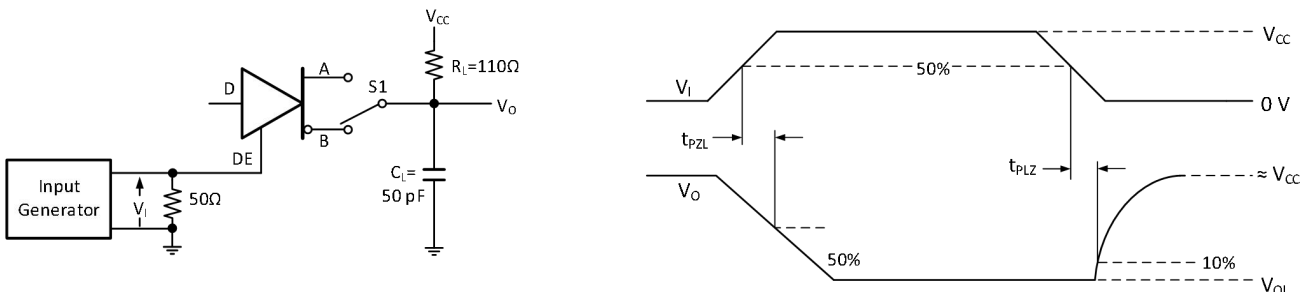

Figure 5. Measurement of Driver Enable and Disable Times with Active Low Output and Pull-up Load

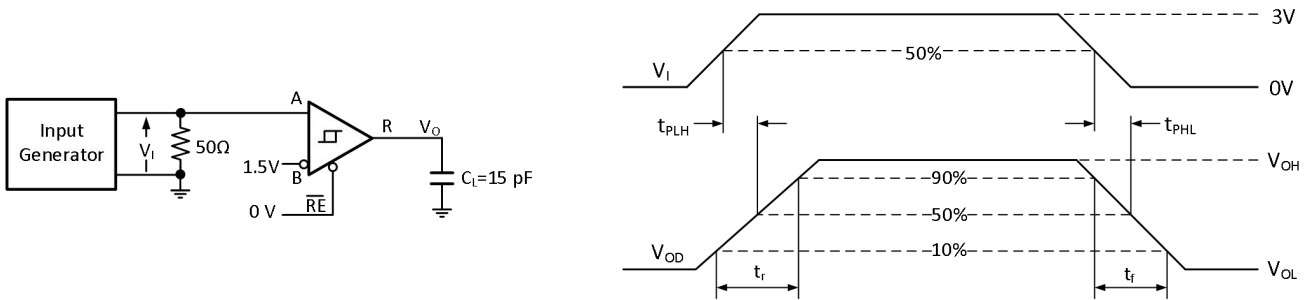

Figure 6. Measurement of Receiver Output Rise and Fall Times and Propagation Delays

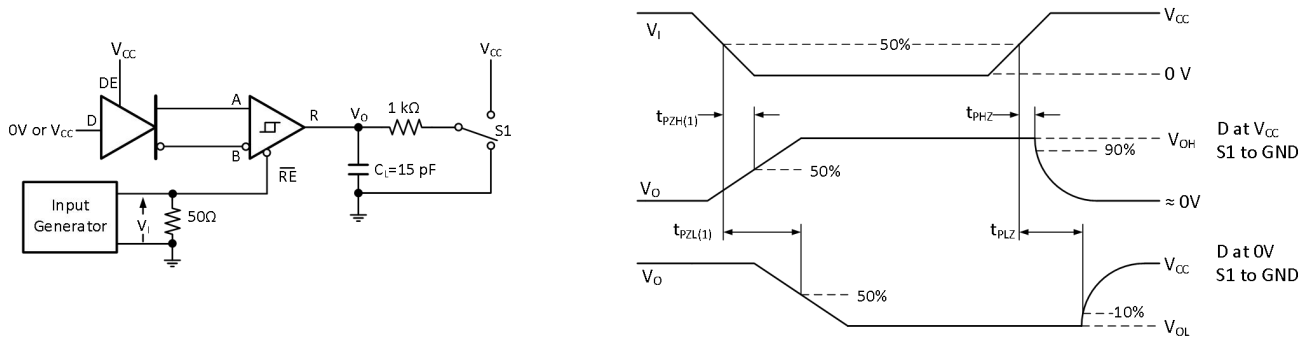

Figure 7. Measurement of Receiver Enable/Disable Times with Driver Enabled

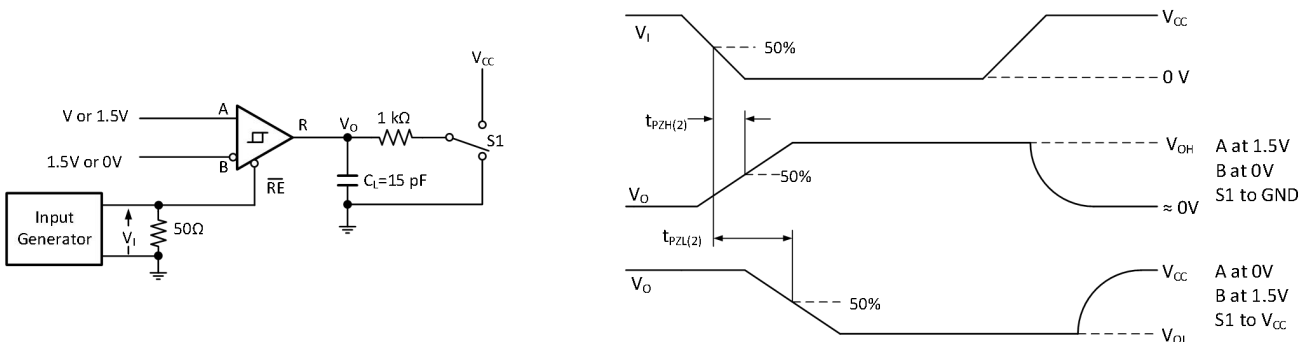

Figure 8. Measurement of Receiver Enable Times with Driver Disabled

4. Typical Application

The COS13487E/COS13488E devices are low-power half-duplex RS-485 transceiver suitable for data transmission at rates up to 12 Mbps over controlled-impedance transmission media (such as twisted-pair cabling). Figure 9 shown an isolated RS-485 Interface using the COS13487E /COS13488E. The transceiver is powered separately from the controlling circuitry. The Auto-direction feature of the COS13487E/COS13488E, replaces an external relay allowing faster switching speeds, no contact bounce, better reliability, and better electrical isolation. The COS13487E/COS13488E only require two opto-couplers to electrically isolate the transceiver.

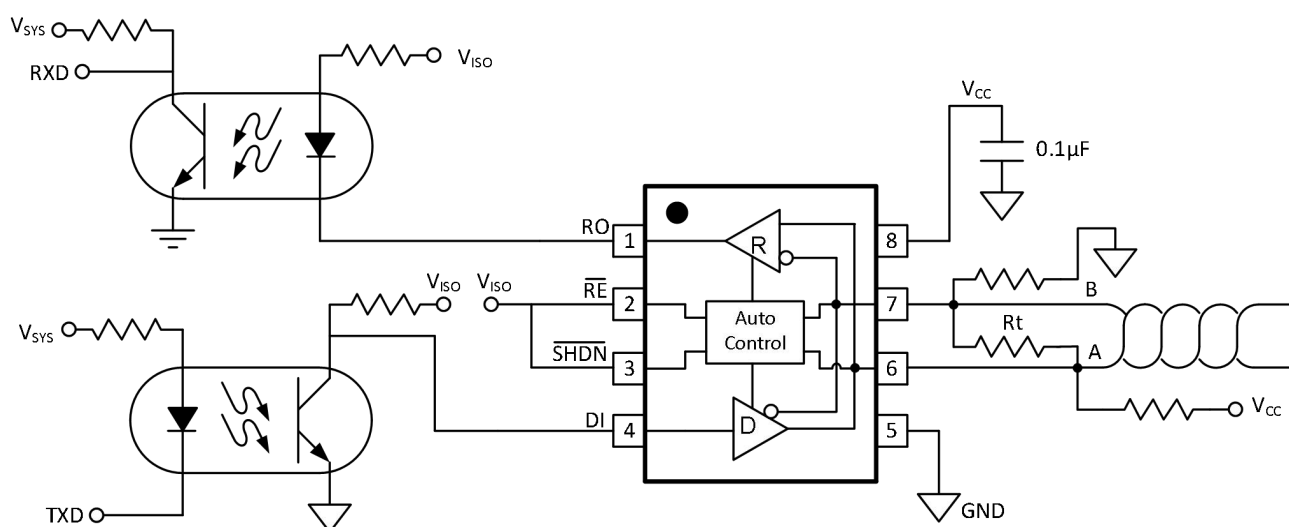

Figure 9. Isolated RS-485 Interface

Internal circuitry in the COS13487E/COS13488E, in conjunction with an external pullup resistor on A and pulldown resistor on B, act to automatically disable or enable the driver and receiver to keep the bus in the correct state. This Auto-direction circuitry consists of a state machine that determines whether this device is trying to drive the bus, or another node on the network is driving the bus. When DI is low, the device always drives the bus low. When DI is high, the device drives the bus for a short time, then disables the driver and allows the external pullup/pulldown resistors to hold the bus in the high state ($A-B > 200\text{mV}$). During each low-to-high transition of DI, the driver stays enabled until $(A-B) > V_{DT}$, and then disables the driver, letting the pullup/pulldown resistors hold the A and B lines in the correct state.

The pullup and pulldown resistors on the A and B lines are required for proper operation of the device although their exact value is not critical. They function to hold the bus in the high state ($A-B > 200\text{mV}$) following a low-to-high transition. Sizing of these resistors is determined in the same way as when using any other RS-485 driver and depends on how the line is terminated and how many nodes are on the bus. The most important factor when sizing these resistors is to guarantee that the idle voltage on the bus ($A-B$) is greater than 200mV in order to remain compatible with standard RS-485 receiver thresholds.

When not transmitting data, the COS13487E/COS13488E require the DI input be driven high to remain in the idle state. A conventional RS-485 transceiver has DE and RE inputs that are used to enable and disable the driver and receiver. However, the COS13487E/COS13488E does not have a DE input, and instead uses an internal state machine to enable and disable the drivers. DI must be driven high in order to go to the idle state.

Up to 256 units of the COS1348x device can share a common RS-485 bus due to the low bus-input currents of the device. A typical application showing a multi-point transmission network is illustrated in Figure 9. Only one driver can transmit at a particular time, but multiple receivers may be enabled simultaneously. As with any transmission line, it is important that reflections are minimized. This can be achieved by terminating the extreme ends of the line using resistors equal to the characteristic impedance of the line. Stub lengths off the main line must also be kept as short as possible. A properly terminated transmission line appears purely resistive to the driver.

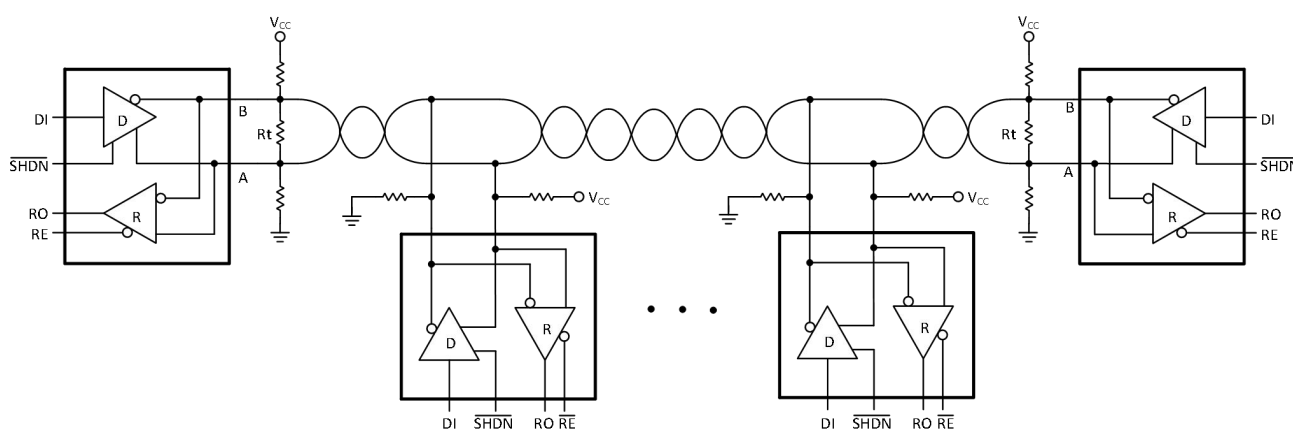
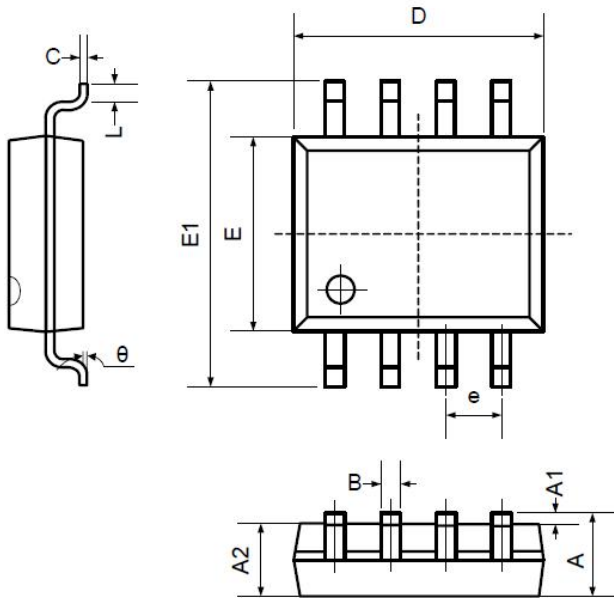

Figure 10. Multi-point Transmission Networks

5. Package Information

6.1 SOP8 (Package Outline Dimensions)



Symbol	Dimensions In Millimeters		Dimensions In Inches	
	Min	Max	Min	Max
A	1.350	1.750	0.053	0.069
A1	0.100	0.250	0.004	0.010
A2	1.350	1.550	0.053	0.061
B	0.330	0.510	0.013	0.020
C	0.190	0.250	0.007	0.010
D	4.780	5.000	0.188	0.197
E	3.800	4.000	0.150	0.157
E1	5.800	6.300	0.228	0.248
e	1.270TYP		0.050TYP	
L	0.400	1.270	0.016	0.050
theta	0°	8°	0°	8°

5.2 MSOP8 (Package Outline Dimensions)

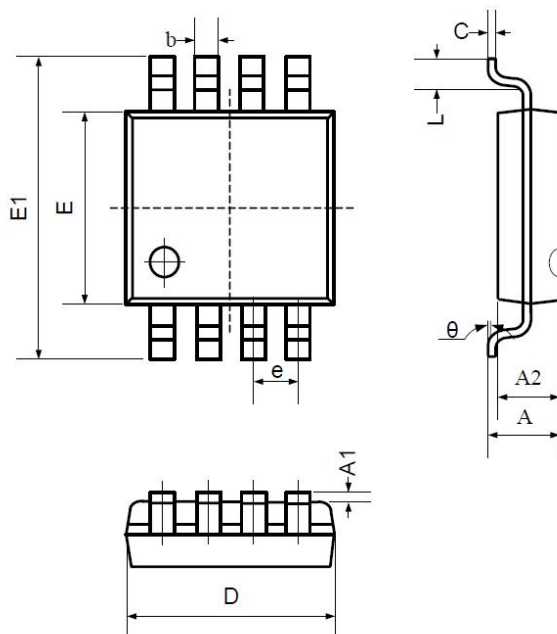

Symbol	Dimensions In Millimeters		Dimensions In Inches	
	Min	Max	Min	Max
A	0.800	1.200	0.031	0.047
A1	0.000	0.200	0.000	0.008
A2	0.760	0.970	0.030	0.038
b	0.30 TYP		0.012 TYP	
c	0.15 TYP		0.006 TYP	
D	2.900	3.100	0.114	0.122
e	0.65 TYP		0.026 TYP	
E	2.900	3.100	0.114	0.122
E1	4.700	5.100	0.185	0.201
L	0.410	0.650	0.016	0.026
theta	0°	6°	0°	6°

6. Ordering Information

Model	Order Number	Package	Package Option	Marking Information
COS13487E	COS13487EESA	SOP-8	Tape and Reel, 4000	COS13487E
	COS13487EM	MSOP-8	Tape and Reel, 3000	COS13487E
	COS13487EF	DFN3x3-8	Tape and Reel, 4000	COS13487E
COS13488E	COS13488EE	SOP-8	Tape and Reel, 4000	COS13488E
	COS13488EM	MSOP-8	Tape and Reel, 3000	COS13488E
	COS13488EF	DFN3x3-8	Tape and Reel, 4000	COS13488E

X-ON Electronics

Largest Supplier of Electrical and Electronic Components

Click to view similar products for [RS-422/RS-485 Interface IC](#) category:

Click to view products by [COSINE](#) manufacturer:

Other Similar products are found below :

[SP3494CN-L/TR](#) [ISL4486IBZ-T](#) [ISL4491EIB](#) [ISL4491EIBZ-T](#) [ISL81483IB](#) [ISL83086EIB](#) [ISL83088EIB](#) [ISL83488IB](#) [ISL8483EIB](#)
[ISL8487EIB](#) [ISL8489EIB](#) [ISL8491IP](#) [ADM489AN](#) [CA-IS3080WX](#) [CA-IS3086WX](#) [NSi83085E-DSWR](#) [SIT65HVD75ETK](#) [GM13487E](#)
[CS48520M](#) [CA-IF4820FD](#) [HSN65HVD12DR](#) [UM3088EESA](#) [ISOW1412BDFMR](#) [MAX485MJA/883B](#) [CA-IF4888HS](#) [CS485M](#)
[CLM3085ESA+](#) [CLM485ESA+](#) [CLM485EESA+](#) [CLM3085EESA+](#) [CS4585EO](#) [WS3471EEUA](#) [WS3079](#) [H485EIMM/TR](#) [SP3485EN-HXY](#)
[SP3483EN-HXY](#) [ST3485EBDR-HXY](#) [MAX1487ESA-HXY](#) [MAX487ESA-HXY](#) [SP485EN-HXY](#) [SN75LBC184DR-HXY](#) [MAX485EESA-](#)
[HXY](#) [SN65LBC184N-HXY](#) [SN75176N-HXY](#) [MAX3485EESA-HXY](#) [SP3485EN-MS](#) [SIT3490EEPA](#) [SP3485EET](#) [UM3488EESA](#)
[CS48505D](#)