

High-Current Low Dropout Regulators

Features

- High Current Capability
 - COS29152/3: 1.5A
 - COS29302/3: 3.0A
 - COS29502/3: 5.0A
 - COS29752/3: 7.5A
- Wide Input Voltage Range: 4~36V
- Low Dropout Voltage
- Low Ground Current
- Accurate 2% Tolerance
- Extremely Fast Transient Response
- Reverse-Battery Protection
- Error Flag Signals Output
Out-of-Regulation
- Adjustable Output Voltage
- Extended Temperature Ranges
From -40°C to +125°C
- Available in Green TO-220, TO-247 and
TO-263 Packages

Applications

- Automotive Electronics
- Battery-Powered Equipment
- High-Efficiency Linear Power Supplies
- High-Efficiency Green Computer Systems
- High-Efficiency Post-Regulator for
Switching Supply

General Description

The COS2915x/2930x/2950x/2975x are high current, high accuracy, low dropout voltage regulators. These regulators feature 350 mV to 425 mV (full load) typical dropout voltages and very low ground current. Designed for high current loads, these devices also find applications in lower current, extremely low dropout critical systems, where their tiny dropout voltage and ground current values are important attributes.

The COS2915x/2930x/2950x/2975x are fully protected against overcurrent faults, reversed input polarity, reversed lead insertion, over temperature operation, and positive and negative transient voltage spikes. Five pin versions feature logic level ON/OFF control (COS29xx2) and an error flag that signals whenever the output falls out of regulation (COS29xx3). Flagged states include low input voltage (drop out), output current limit, over temperature shutdown, and extremely high voltage spikes on the input.

The COS2915x/2930x/2950x are available in 5-pin TO-220. The COS2975x 7.5A regulators are available in a 5-pin TO-247 package.

1 Pin Configuration and Functions

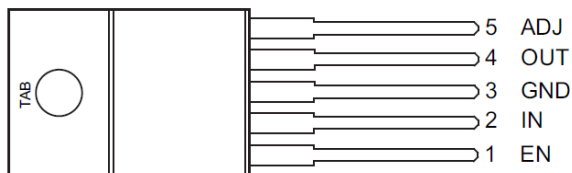

COS29152/29302/29502/29752

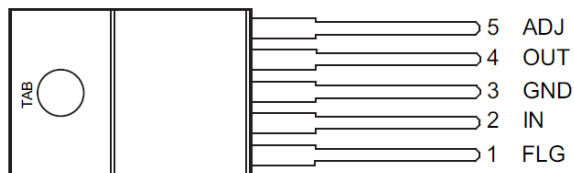

COS29153/29303/29503/29753

Pin Functions

Pin No	Pin Name	I/O	Description
2	IN	I	INPUT: Supplies the current to the output power device.
4	OUT	O	OUTPUT: The regulator output voltage.
3	GND	-	GROUND
1	EN	I	ENABLE: Available for COS29xx2. CMOS compatible control input. Logic-high=enable, logic-low=shutdown
5	ADJ	I	ADJUST: Adjustable regulator feedback input that connects to the resistor voltage divider that is placed from OUT to GND in order to set the output voltage.
1	FLG	O	FLAG: Available for COS29xx3. Active-low error flag output signal that indicates an output fault condition.
-	TAB	-	Internally connected directly to the device pin3 (GND). The thermal tab must be connected to a copper area on the PCB at the same potential as device pin3 (GND) to assure thermal performance, or leave the thermal tab floating. Do NOT connect the thermal tab to any potential other than the same potential at device pin3.

2 Product Specification

2.1 Absolute Maximum Ratings ⁽¹⁾

Parameter	Rating	Units
Maximum Input Voltage: V_{IN}	+36V	V
Enable Input Voltage	- 0.3V to V_{IN}	V
Storage Temperature Range	-55 to 150	°C
Operating Junction Temperature Range	-40 to 125	°C
ESD Susceptibility, HBM	2000	V

(1) Stresses exceeding the absolute maximum ratings may damage the device. The device may not function or be operable above the recommended operating conditions and stressing the parts to these levels is not recommended. In addition, extended exposure to stresses above the recommended operating conditions may affect device reliability. The absolute maximum ratings are stress ratings only.

2.2 Thermal Data

Parameter	Rating	Unit
Package Thermal Resistance (Junction-to-case)	2 (TO-220) 2 (TO-263) 1.5 (TO-247) 3 (TO-252)	°C/W

2.3 Recommended Operating Conditions

Parameter	Rating	Unit
Input Supply Voltage	+4.5V ~ +30V	V
Operating ambient temperature	-40 to +85	°C

2.4 Electrical Characteristics

($V_{IN}=V_{OUT} + 1V$, $I_{OUT}=10mA$, $T_J=+25^{\circ}C$, unless otherwise noted)

Parameter	Symbol	Conditions	Min.	Typ.	Max.	Unit
Output Voltage	V_{OUT}	$I_{OUT} = 10mA$	-1	-	+1	%
		$10mA \leq I_{OUT} \leq I_{FL}$, $(V_{OUT} + 1V) \leq V_{IN} \leq 26V$	-2	-	+2	%
Line Regulation		$I_{OUT}=10mA$		0.3	0.6	%
Load Regulation		$10mA \leq I_{OUT} \leq 1.5A$		0.2	3	%
Output Voltage Temperature Coefficient	$\Delta V_o / \Delta T$			20	100	ppm/ $^{\circ}C$
Dropout Voltage $\Delta V_{OUT} = -1\%$		COS2915x, $I_{OUT}=100mA$	-	80	200	mV
		COS2915x, $I_{OUT}=750mA$	-	220	-	
		COS2915x, $I_{OUT}=1.5A$	-	310	600	
		COS2930x, $I_{OUT}=100mA$	-	80	175	
		COS2930x, $I_{OUT}=1.5A$	-	250	-	
		COS2930x, $I_{OUT}=3A$	-	370	600	
		COS2950x, $I_{OUT}=250mA$	-	125	250	
		COS2950x, $I_{OUT}=2.5A$	-	250	-	
		COS2950x, $I_{OUT}=5A$	-	370	600	
		COS2975x, $I_{OUT}=250mA$	-	50	-	
		COS2975x, $I_{OUT}=4A$	-	180	-	
		COS2975x, $I_{OUT}=7.5A$	-	300	-	
Ground Current ($V_{IN} = V_{OUT} + 1V$)	I_{GND}	COS2915x, $I_{OUT}=750mA$ $V_{IN} = V_{OUT} + 1V$	-	5.2	-	mA
		COS2915x, $I_{OUT}=1.5A$	-	28	-	
		COS2930x, $I_{OUT}=1.5A$ $V_{IN} = V_{OUT} + 1V$	-	5.2	-	
		COS2930x, $I_{OUT}=3A$	-	28	-	
		COS2950x, $I_{OUT}=2.5A$ $V_{IN} = V_{OUT} + 1V$	-	5.2	-	
		COS2950x, $I_{OUT}=5A$	-	28	-	
		COS2975x, $I_{OUT}=4A$ $V_{IN} = V_{OUT} + 1V$	-	5.2	-	
		COS2975x, $I_{OUT}=7.5A$	-	28	-	
Ground Pin Current at Dropout	I_{GRNDDO}	COS2915x, $I_{OUT}=10mA$	-	1.9	-	mA



COS2915X/2930X/2950X/2975X

(V _{IN} is 0.5V less than specified V _{OUT})		COS2930x, I _{OUT} =10mA	-	1.9	-	
		COS2950x, I _{OUT} =10mA	-	1.9	-	
		COS2975x, I _{OUT} =10mA	-	1.9	-	
Current Limit	I _{LIM}	COS2915x, V _{OUT} =0V	-	2.1	3.5	A
		COS2930x, V _{OUT} =0V	-	4.1	5.0	
		COS2950x, V _{OUT} =0V	-	6.8	10.0	
		COS2975x, V _{OUT} =0V	-	10	15.0	
Ground Current in Shutdown			-	5	75	nA
Output Noise Voltage	e _n	C _L =10μF, I _L =100mA, 10Hz to 100kHz	-	390	-	μVrms
		C _L =33μF, I _L =100mA, 10Hz to 100kHz	-	211	-	μVrms
Reference						
Reference Voltage			1.22	1.240	1.252	V
Reference Voltage Temperature Coefficient			-	20	-	ppm/°C
Adjust Pin Bias Current			-	-	100	pA
Flag Output						
Output Low Voltage	V _{OL}				400	mA
Hysteresis				15		mV
ENABLE Input						
Input Logic Voltage Low (OFF)			-	-	0.8	V
Input Logic Voltage High (ON)			2.4	-	-	V
Enable Pin Input Current		V _{EN} =0.8V	-	-	24	pA
		V _{EN} =26V	-	-	3	nA
Regulator Output Current in Shutdown		- 40° C ≤ T _J ≤ +125° C	-	-	18	μA

3 Application Notes

The COS2915x, COS2930x, COS2950x, and COS2975x are high-performance low-dropout voltage regulators suitable for all moderate to high-current voltage regulator applications. Their 350 mV to 425 mV typical dropout voltage at full load make them especially valuable in battery powered systems and as high efficiency noise filters in post-regulator applications.

The COS2915x/2930x/2950x/2975x family of regulators are fully protected from damage due to fault conditions. Current limiting is provided. This limiting is linear; output current under overload conditions is constant. Thermal shutdown disables the device when the die temperature exceeds the +125°C maximum safe operating temperature. Line transient protection allows device and load

survival even when the input voltage spikes between $-20V$ and $+40V$. When the input voltage exceeds approximately $36V$, the overvoltage sensor disables the regulator. The output structure of these regulators allows voltages in excess of the desired output voltage to be applied without reverse current flow. COS29xx2 versions offer a logic-level ON/OFF control. When disabled, the devices draw nearly zero current. An additional feature of this regulator family is a common pinout. A design's current requirement may change up or down, but use the same board layout because all of these regulators have identical pinouts.

3.1 Typical Application Circuit

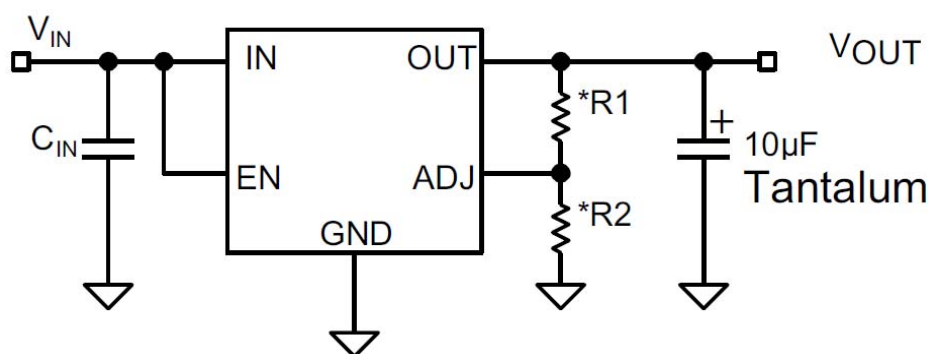

Figure 1 Typical Application Circuit

*see minimum load current section. On the COS29xx2, the EN (ENABLE) pin may be tied to V_{IN} if it is not required for ON/OFF control.

3.2 Capacitor Requirements

For stability and minimum output noise, a capacitor on the regulator output is necessary. The value of this capacitor is dependent upon the output current; lower currents allow smaller capacitors. The COS2915x/2930x/2950x/2975x regulators are stable with the following minimum capacitor values at full load, as noted in Table 4-1. This capacitor need not be an expensive low ESR type: aluminum electrolytics are adequate. In fact, extremely low ESR capacitors may contribute to instability. Tantalum capacitors are recommended for systems where fast load transient response is important where the regulator is powered from a source with high AC impedance, a $0.1\mu F$ capacitor connected between Input and GND is recommended. This capacitor should have good characteristics to above 250 kHz.

Table 4-1 Minimum capacitor values at full load

Device	Full-Load Capacitor
COS1915x	$10\mu F$
COS1930x	$10\mu F$
COS1950x	$10\mu F$
COS1975x	$22\mu F$

3.3 Minimum Load Current

The COS2915x–2975x regulators are specified between finite loads. If the output current is too small, leakage currents dominate and the output voltage rises. The following minimum load current swamps any expected leakage current across the operating temperature range, as shown in Table 4-2.

Table 4-2 Minimum Load Currents

Device	Minimum Load
COS1915x	5mA
COS1930x	7mA
COS1950x	10mA
COS1975x	10mA

3.4 Adjustable Regulator Design

COS29xx2 and COS29xx3, allow programming the output voltage anywhere between 1.25V and the 25V. Two resistors are used. The resistor values are calculated by following equation.

$$R_1 = R_2 \times (V_{OUT}/1.240 - 1)$$

In the equation above, V_{OUT} is the desired output voltage. The typical application circuit in Figure1 shows component definition. Applications with widely varying load currents may scale the resistors to draw the minimum load current required for proper operation (see the Minimum Load Current sub-section).

3.5 Error Flag

COS29xx3 versions feature an Error Flag, which looks at the output voltage and signals an error condition when this voltage drops 5% below its expected value. The error flag is an open-collector output that pulls low under fault conditions. It may sink 10 mA. Low output voltage signifies a number of possible problems, including an overcurrent fault (the device is in current-limit) and low input voltage. The flag output is functional during over-temperature shutdown conditions.

3.6 Enable Input

COS29xx2 versions feature an enable (EN) input that allows ON/OFF control of the device. Special design allows “zero” current drain when the device is disabled; only microamperes of leakage current flows. The EN input has TTL/CMOS compatible thresholds for simple interfacing with logic, or may be directly tied to $\leq 30V$.

X-ON Electronics

Largest Supplier of Electrical and Electronic Components

Click to view similar products for [Linear Voltage Regulators](#) category:

Click to view products by [COSINE](#) manufacturer:

Other Similar products are found below :

[LV5684PVD-XH](#) [MCDTSA6-2R](#) [L7815ACV-DG](#) [LV56801P-E](#) [UA7805CKC](#) [714954EB](#) [ZMR500QFTA](#) [BA033LBSG2-TR](#)
[NCV78M05ABDTRKG](#) [LV5680P-E](#) [L79M05T-E](#) [L78LR05D-MA-E](#) [NCV317MBTG](#) [NTE7227](#) [MP2018GZD-33-P](#) [MP2018GZD-5-P](#)
[LV5680NPVC-XH](#) [ZTS6538SE](#) [UA78L09CLP](#) [UA78L09CLPR](#) [CAT6221-PPTD-GT3](#) [MC78M09CDTRK](#) [NCV51190MNTAG](#)
[BL1118CS8TR1833](#) [BL8563CKETR18](#) [BL8077CKETR33](#) [BL9153-33CC3TR](#) [BL9161G-15BADRN](#) [BL9161G-28BADRN](#)
[BRCO7530MMC](#) [CJ7815B-TFN-ARG](#) [LM317C](#) [GM7333K](#) [GM7350K](#) [XC6206P332MR](#) [HT7533](#) [LM7912S/TR](#) [LT1764S/TR](#) [LM7805T](#)
[LM338T](#) [LM1117IMP-3.3/TR](#) [HT1117AM-3.3](#) [HT7550S](#) [AMS1117-3.3](#) [HT7150S](#) [78L12](#) [HT7550](#) [HT7533-1](#) [HXY6206I-2.5](#) [HT7133](#)