

Single 9A High-Speed, Low-Side Gate Driver

Features

- High Peak Output Current: 9A
- High Continuous Output Current: 2A
- Wide Supply Voltage Operating Range: 4.5V to 18V
- High Capacitive Load Drive Capability 10nF in 35ns (typical)
- Short Delay Times: 58ns (typical)
- Matched Rise/Fall Times
- Low Output Impedance: 0.5Ω (typical)
- Low Supply Current
- Over-Temperature Protection
- Under-Voltage Lockout (UVLO)
- Non-overlapped Drive Tech
- Enable Function (Pull Low to inhibit driver)
- Input withstands negative inputs up to 5V
- Available in Green SOP8, DIP8 and DFN8 Packages

Applications

- Driving the large MOSFET, SiC and IGBT
- Line Drivers for Heavily Loaded Lines
- Local Power ON/OFF Switch
- Motor and Solenoid Driver
- Switch Mode Power Supplies

Rev1.0

Copyright©2020 Cosine Nanoelectronics Inc. All rights reserved
 The information provided here is believed to be accurate and reliable. Cosine Nanoelectronics assumes no reliability for inaccuracies and omissions. Specifications described and contained here are subjected to change without notice on the purpose of improving the design and performance. All of this information described herein should not be implied or granted for any third party.

General Description

The COS3121 and COS3122 are single channel, high-current low-side gate drivers capable of driving large MOSFET, SiC, GaN and IGBTs. Unique circuit design enables high speed operation capable of delivering peak currents of 9A into 10,000pF capacitive loads. Improved speed and drive capability are enhanced by matched rise and fall delay times. Dynamic switching losses are minimized with non-overlapped drive techniques. These devices are highly latch-up resistant within their power and voltage ratings. They are not subject to damage when up to 5V of noise spiking (of either polarity) occurs on the ground pin.

The COS3121/3122 inputs can be driven directly from either TTL or CMOS (3V to 18V). In addition, the 300 mV of built-in hysteresis provides noise immunity and allows the device to be driven from slow rising or falling waveforms. Output is held LOW if Input is unbiased or floating.

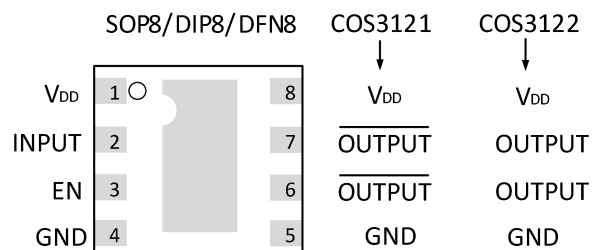

Pin Diagram

1. Pin Configuration and Functions

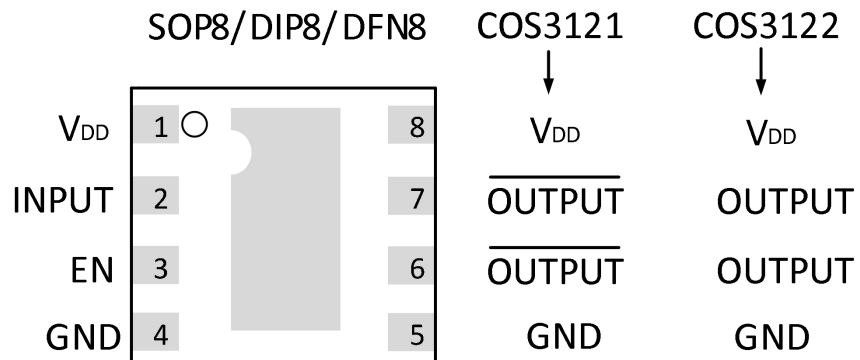

Truth Table

EN	IN	OUT (COS3121)	OUT (COS3122)
0	0	0	0
0	1	0	0
1	0	1	0
1	1	0	1

Figure 1. Pin Diagram and Truth Table

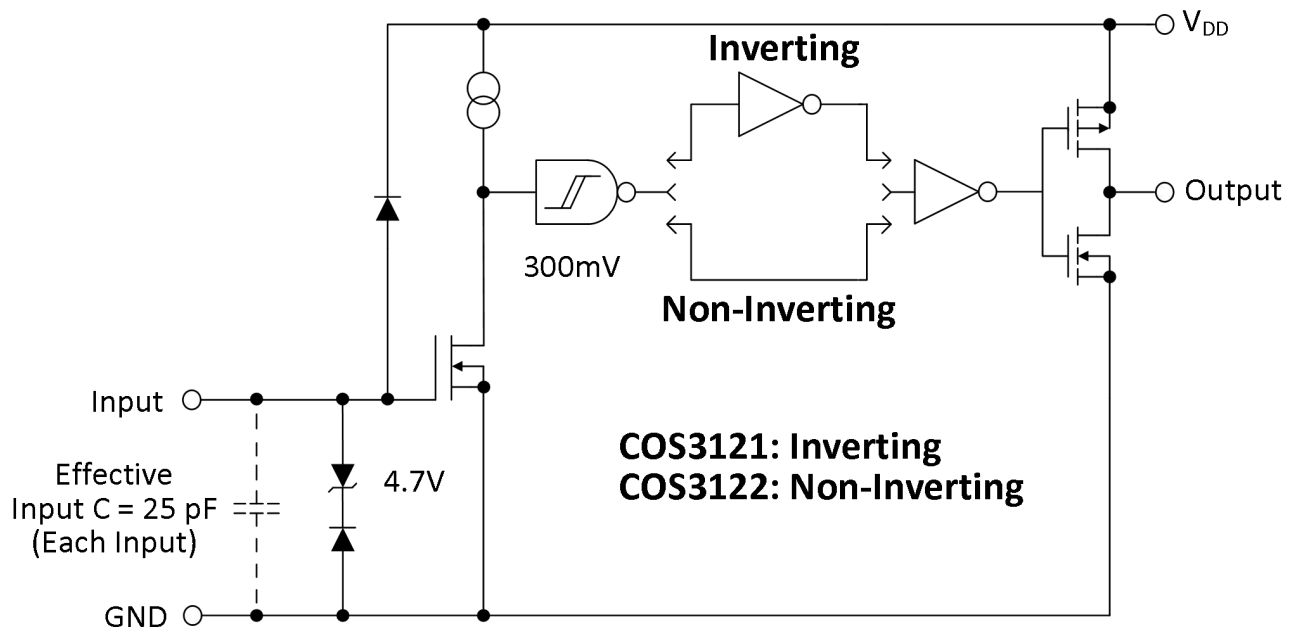

Figure 2. Functional Block Diagram

Pin Description

Pin	Name	Description
1	VDD	Power Supply
2	INPUT	Control input, TTL/CMOS compatible input
3	EN	Enable Input, TTL/CMOS compatible input. Pull pin LOW to inhibit driver.
4	GND	Ground
5	GND	Ground
6	OUTPUT	CMOS push-pull output
7	OUTPUT	CMOS push-pull output
8	VDD	Power Supply
-	PAD	Exposed Metal Pad, electrically isolated. Available only to DFN package.

Note: Duplicate pins must both be connected for proper operation.

1.1 Input

MOSFET driver input is a high-impedance, TTL/CMOS compatible input. It also has 300 mV of hysteresis between the high and low thresholds that prevents output glitching even when the rise and fall time of the input signal is very slow.

1.2 Ground (GND)

Ground is the device return pin. The Ground pin(s) should have a low-impedance connection to the bias supply source return. High peak current flows out the Ground pin(s) when the capacitive load is being discharged.

1.3 Output

MOSFET driver outputs are low-impedance, CMOS push-pull style outputs. The pull-down and pullup devices are of equal strength, making the rise and fall times equivalent. The Output is held LOW if Input is unbiased or floating.

1.4 EN

Enable input for the driver with logic compatible threshold and hysteresis. The driver output can be enabled and disabled with this pin. It is internally pulled up to V_{DD} with 100 k Ω resistor for active high operation. The output state when the device is disabled will be low regardless of the input state.

1.5 Supply Input (VDD)

The VDD input is the bias supply for the MOSFET driver and is rated for 4.5V to 18V with respect to the Ground pin. The VDD input should be bypassed with local ceramic capacitors. The value of these capacitors should be chosen based on the capacitive load that is being driven. A value of 1.0 μ F is suggested.

1.6 Exposed Metal Pad

The exposed metal pad of the DFN-S package is not internally connected to any potential. Therefore, this pad can be connected to a ground plane or other copper plane on a Printed Circuit Board (PCB), to aid in heat removal from the package.

2. Ordering Information

Model	Package	Order Number	Package Option	Marking Information
COS3121	SOP-8	COS3121SR	Tape and Reel, 4000	COS3121
	DFN-8	COS3121FR	Tape and Reel, 3000	COS3121
	DIP-8	COS3121DR	Tube 50	COS3121
COS3122	SOP-8	COS3122SR	Tape and Reel, 4000	COS3122
	DFN-8	COS3122FR	Tape and Reel, 3000	COS3122
	DIP-8	COS3122DR	Tube 50	COS3122

3. Product Specification

3.1 Absolute Maximum Ratings ⁽¹⁾

Parameter	Min	Max	Unit
DC supply voltage V_{DD}		25	V
Operating junction temperature	-40	+125	°C
Storage temperature	-55	+150	°C
Maximum input voltage	GND-5	$V_{DD}+0.3$	V

(1) Stresses exceeding the absolute maximum ratings may damage the device. The device may not function or be operable above the recommended operating conditions and stressing the parts to these levels is not recommended. In addition, extended exposure to stresses above the recommended operating conditions may affect device reliability. The absolute maximum ratings are stress ratings only.

3.2 Thermal Data

Parameter	Rating	Unit
Package Thermal Resistance, $R_{\theta JA}$ (Junction-to-ambient)	155(SOP8) 125(DIP8) 118(DFN8,2x2)	°C/W

3.3 Recommended Operating Conditions

Parameter	Rating	Unit
DC Supply Voltage	4.5V ~ 18V	V
Operating ambient temperature	-40 to +125	°C

3.4 Electrical Characteristics

(Typical values are tested at $T_A=25\text{ }^\circ\text{C}$, $V_{DD}=18\text{V}$)

Parameter	Symbol	Conditions	Min.	Typ.	Max.	Unit
INPUT						
Input Signal High Threshold	V_{IH}		1.6			V
Input Signal Low Threshold	V_{IL}				0.7	V
Input Signal Hysteresis	V_{HYS}			0.3		V
Input Signal High Current	I_{IH}	Inverting Input Current, $V_{INX}=18\text{V}$			0.01	μA
		Non-inverting Input Current, $V_{INX}=18\text{V}$		88	125	
Input Signal High Current	I_{IL}	Inverting Input Current, $V_{INX}=0\text{V}$		88	125	μA
		Non-inverting Input Current, $V_{INX}=0\text{V}$			0.01	
OUTPUT						
High Output Voltage V_{OH}	V_{OH}	DC Test	$V_{DD} - 0.025$			V
Low Output Voltage	V_{OL}	DC Test			0.025	V
Pull-Up Resistance	R_{OH}	Source Current = 10mA		0.83		Ω
Pull-Down Resistance	R_{OL}	Sink Current = -10mA		0.5		Ω
Peak Output Current	I_{PK}	$10\text{V} \leq V_{DD} \leq 18\text{V}$		9.0		A
POWER SUPPLY						
Power Supply Current	I_{CC}	$V_{IN}=3\text{V}$		0.85		mA
		$V_{IN}=0\text{V}$		0.65		
Operating Voltage Range	V_{DD}		4.5		18	V
Under-Voltage Lockout ON Threshold				3.7	4.1	V
Under-Voltage Lockout Hysteresis				0.5		V

SWITCHING CHARACTERISTICS						
Rise Time	t_R	$C_L = 10,000 \text{ pF}$, See Figure 3		35		ns
Fall Time	t_F	$C_L = 10,000 \text{ pF}$, See Figure 3		36		ns
Turn-On Delay Time	t_{D1}	COS3121, $C_L = 10,000 \text{ pF}$		58		ns
		COS3122, $C_L = 10,000 \text{ pF}$		60		ns
Turn-Off Delay Time	t_{D2}	COS3121, $C_L = 10,000 \text{ pF}$		59		ns
		COS3122, $C_L = 10,000 \text{ pF}$		63		ns
OVER-TEMPERATURE PROTECTION						
Thermal Shutdown Threshold				150		$^{\circ}\text{C}$
Thermal Shutdown Threshold Hysteresis				25		$^{\circ}\text{C}$

4. Application Information

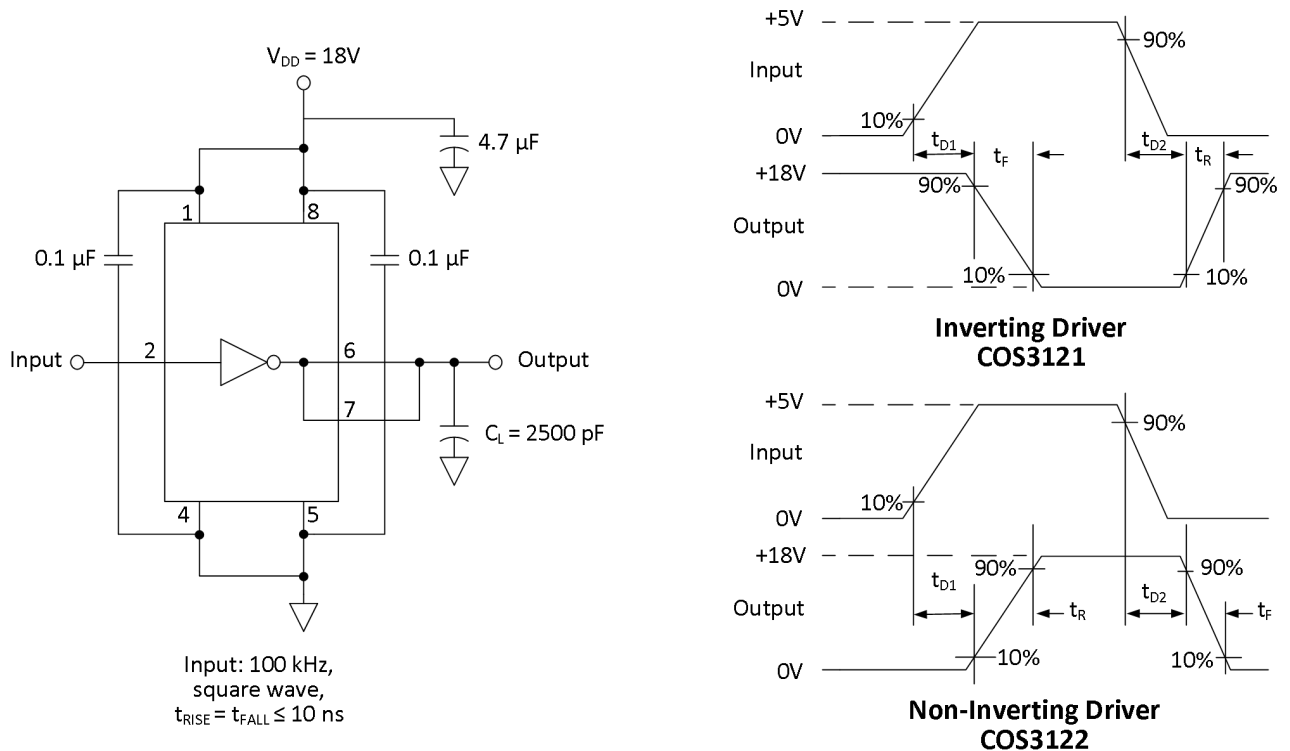
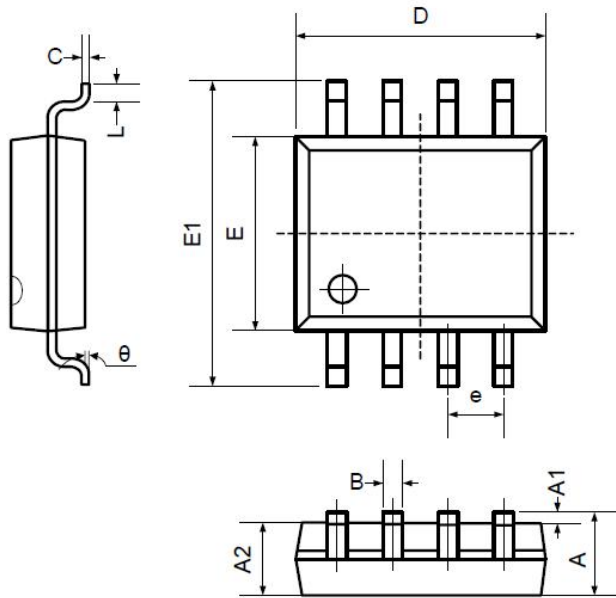

Figure 3. Switching Time Test Circuit

5. Package Information

5.1 SOP8 (Package Outline Dimensions)



Symbol	Dimensions In Millimeters		Dimensions In Inches	
	Min	Max	Min	Max
A	1.350	1.750	0.053	0.069
A1	0.100	0.250	0.004	0.010
A2	1.350	1.550	0.053	0.061
B	0.330	0.510	0.013	0.020
C	0.190	0.250	0.007	0.010
D	4.780	5.000	0.188	0.197
E	3.800	4.000	0.150	0.157
E1	5.800	6.300	0.228	0.248
e	1.270TYP		0.050TYP	
L	0.400	1.270	0.016	0.050
θ	0°	8°	0°	8°

5.2 DIP8 (Package Outline Dimensions)

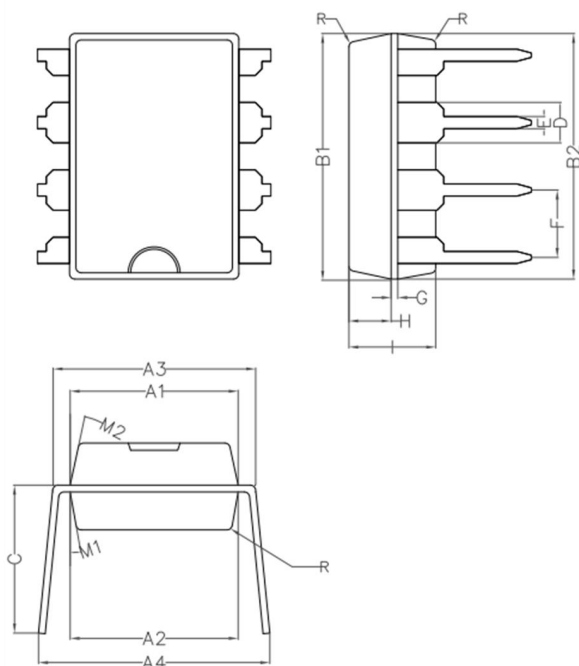

Symbol	Min	Non	Max
A1	6.28	6.33	6.38
A2	6.33	6.38	6.43
A3	7.52	7.62	7.72
A4	7.80	8.40	9.00
B1	9.15	9.20	9.25
B2	9.20	9.25	9.30
C		5.57	
D		1.52	
E	0.43	0.45	0.47
F		2.54	
G		0.25	
H	1.54	1.59	1.64
I	3.22	3.27	3.32
R		0.20	
M1	9°	10°	11°
M2	11°	12°	13°

5.3 6x5 DFN-8 (Package Outline Dimensions)

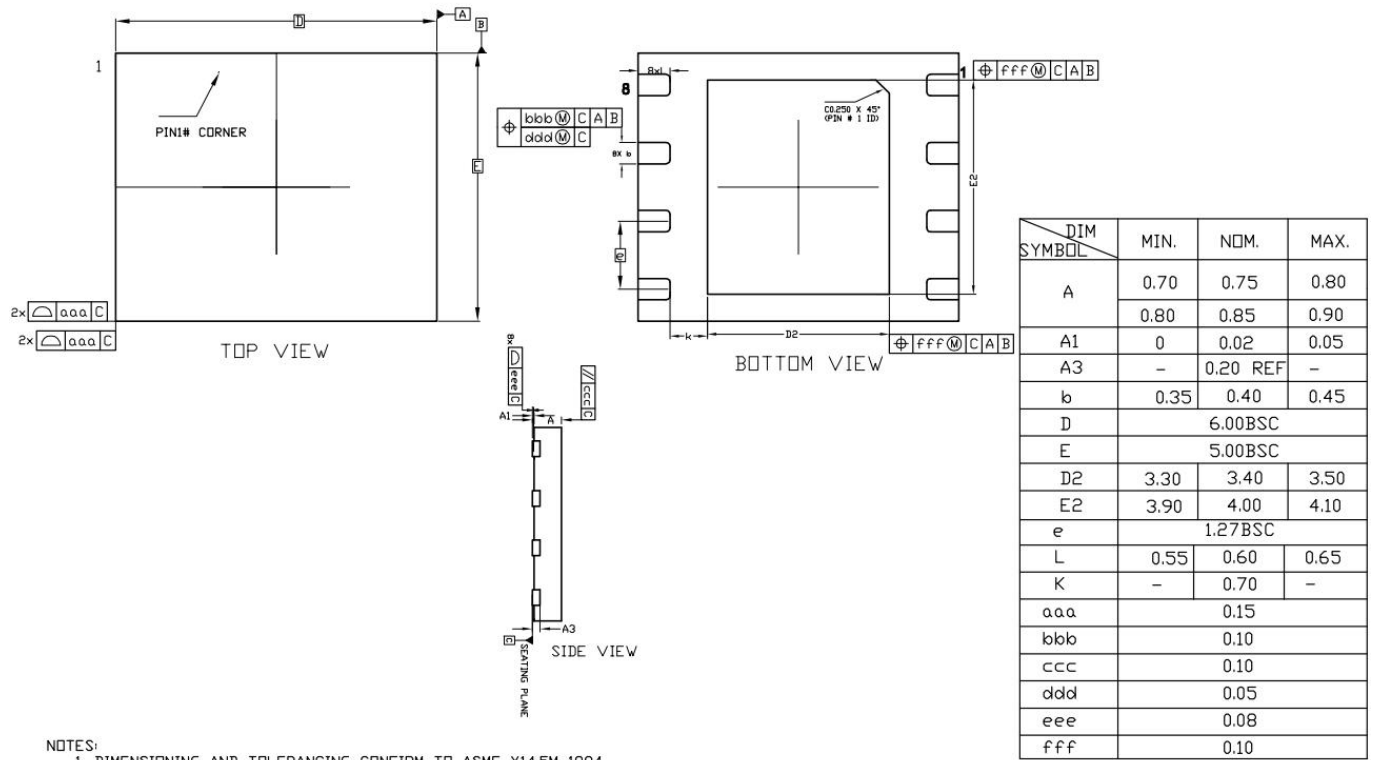

NOTES:
1. DIMENSIONING AND TOLERANCING CONFIRM TO ASME Y14.5M-1994

X-ON Electronics

Largest Supplier of Electrical and Electronic Components

Click to view similar products for [Gate Drivers](#) category:

Click to view products by [COSINE](#) manufacturer:

Other Similar products are found below :

[56956](#) [57.404.7355.5](#) [LT4936](#) [57.904.0755.0](#) [5811-0902](#) [0131700000](#) [LTP70N06](#) [LVP640](#) [5J0-1000LG-SIL](#) [LY2-US-AC240](#) [LY3-UA-DC24](#) [LZNQ2-US-DC12](#) [LZP40N10](#) [60100564](#) [60249-1-CUT-TAPE](#) [0134220000](#) [60713816](#) [61161-90](#) [6131-204-23149P](#) [6131-205-17149P](#) [6131-209-15149P](#) [6131-218-17149P](#) [6131-220-21149P](#) [6131-260-2358P](#) [6131-265-11149P](#) [CS1HCPU63](#) [6150-5001](#) [CSB4](#) [CSK-38-60006](#) [CSK-38-60008](#) [621A](#) [622-4053LF](#) [6273](#) [M40N08MA-H](#) [M55155/29XH06](#) [64-807](#) [65-1930-6](#) [CV500ISB02](#) [M83723/88Y1407N](#) [CWD012-2](#) [CWD03-3](#) [CX3225SB16934D0PPSC2](#) [CX5032GB10000D0PPS02](#) [687-772NF1](#) [70.140.1653](#) [70.200.0653.0](#) [703001B01F060](#) [70-3601](#) [706006D02F0601](#) [706210](#)