

1.6V to 7V, Low-power Push-Pull Output Comparators

Features

- Operates on 1.6V ~ 7.0V Supplies
- Low Quiescent Current: 18 μ A at 1.8V
- Low Propagation Delay: 200 ns
- Low Input Offset Voltage: 1 mV
- Push-Pull Outputs
- Input Common Mode Voltage Range Includes Ground
- Input Bias Current: 1.0 pA Typical
- No Phase Inversion for Overdrive Inputs
- Extended Temperature Ranges From -40°C to +125°C
- Small Packaging: SOT23-5 and SC70-5

Applications

- Inspection Equipment
- Threshold Detectors/Discriminators
- Peak and Zero-crossing detectors
- Logic Level Shifting or Translation
- Portable Equipment
- Sensor Conditioning
- High-Speed Sampling Systems
- Battery Powered Electronics

General Description

The COS3201 is a single channel low-power comparator which features wide supply voltage range and rail-to-rail push-pull output. Their operating voltage ranges from +1.6V to +7.0V, making them ideal for 1.8, 3.3V and 5V systems. It consumes only 25 μ A while achieving a 200ns propagation delay. Input bias current is typically 1.0pA, and input offset voltage is typically 1 mV.

The COS3201 has push-pull output stages capable of sinking and sourcing milliamps of current when controlling an LED or driving a capacitive load. The COS3201 is available in tiny 5-pin SOT23-5 and SC70-5 packages.

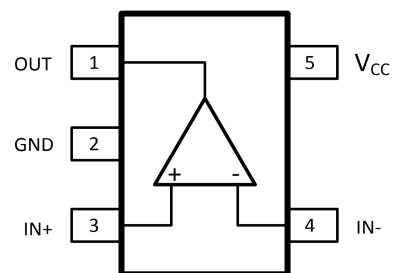

COS3201

Rev1.0
Copyright©2018 Cosine Nanoelectronics Inc. All rights reserved
The information provided here is believed to be accurate and reliable. Cosine Nanoelectronics assumes no liability for inaccuracies and omissions. Specifications described and contained here are subjected to change without notice on the purpose of improving the design and performance. All of this information described herein should not be implied or granted for any third party.

1. Pin Configuration and Functions

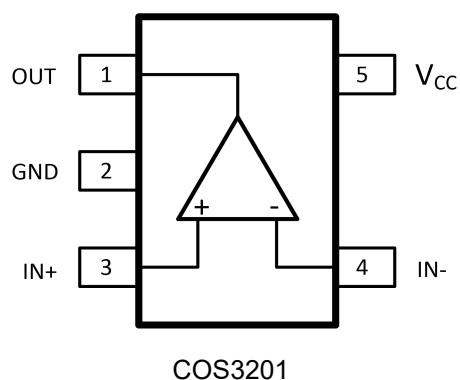

Pin Functions

PIN No.	Name	Type	Description
1	OUT	O	Output
2	GND	P	Ground
3	IN+	I	Positive input
4	IN-	I	Negative input
5	Vcc	P	Positive power supply

2. Package and Ordering Information

Model	Channel	Order Number	Package	Package Option	Marking Information
COS3201	1	COS3201TR	SOT23-5	Tape and Reel, 3000	C3201
		COS3201CR	SC70-5	Tape and Reel, 3000	C3201

3. Product Specification

3.1 Absolute Maximum Ratings ⁽¹⁾

Parameter	Rating	Units
Power Supply: Vcc to GND	7.5	V
Input Voltage	-Vs -0.5V to +Vs + 0.5V	V
Input Current ⁽²⁾	±10	mA
Storage Temperature Range	-65 to 150	°C
Junction Temperature	150	°C
Operating Temperature Range	-40 to 125	°C
ESD Susceptibility, HBM	2000	V

(1) Stresses exceeding the absolute maximum ratings may damage the device. The device may not function or be operable above the recommended operating conditions and stressing the parts to these levels is not recommended. In addition, extended exposure to stresses above the recommended operating conditions may affect device reliability. The absolute maximum ratings are stress ratings only.

(2) Input terminals are diode-clamped to the power-supply rails. Input signals that can swing more than 0.5V beyond the supply rails should be current-limited to 10mA or less.

3.2 Thermal Data

Parameter	Rating	Unit
Package Thermal Resistance	190 (SOT23-5)	°C/W

3.3 Recommended Operating Conditions

Parameter	Rating	Unit
DC Supply Voltage	1.6 ~ 7	V
Input common-mode voltage range	-Vs ~ +Vs-0.5	V
Operating ambient temperature	-40 to +85	°C

3.4 Electrical Characteristics

($V_{CC}=5V$, $V_{CM}=V_{CC}/2$, $C_L=15pF$, $T_A=+25^{\circ}C$, unless otherwise noted)

Parameter	Symbol	Conditions	Min	Typ	Max	Unit
Input Characteristics						
Input Offset Voltage	V_{OS}			1.0	5.0	mV
Input Offset Voltage Drift	$\Delta V_{OS}/\Delta T$	-40 to 125°C		5		$\mu V/^{\circ}C$
Input Bias Current	I_B			1.0	10	pA
Input Offset Current	I_{OS}			1.0	10	pA
Common-Mode Voltage Range	V_{CM}	$V_S = 5.5V$	-0.1		4.5	V
Common-Mode Rejection Ratio	CMRR	$V_{CM} = 0.1V$ to 4.5V		70		dB
Output Characteristics						
Voltage Output Swing from Lower Rail	V_{OL}	$I_{SINK}=5mA$		164		mV
Voltage Output Swing from Upper Rail	V_{OH}	$I_{SOURCE}=5mA$		118		mV
Short-Circuit Current	I_{SR}	Sourcing		57		mA
	I_{SK}	Sinking		50		mA
Power Supply						
Operating Voltage Range			1.6		7.0	V
Power Supply Rejection Ratio	PSRR	$V_S = +1.8V$ to +5.5V	70	90		dB
Quiescent Current / Amplifier	I_Q	$V_S = +1.8V$		18		μA
		$V_S = +3.3V$		27		μA
		$V_S = +5.0V$		28		μA
Switching Characteristics						
Propagation Delay Time, High to Low	t_{PHL}	$V_{OD}=100mV$		200		ns
Propagation Delay Time, Low to High	t_{PLH}	$V_{OD}=100mV$		200		ns
Rise Time	t_R	20% to 80%		5		ns
Fall Time	t_F	80% to 20%		5		ns

4.0 Application Notes

Inverting Comparator with Hysteresis

When higher levels of hysteresis are required, positive feedback can be externally added. The inverting comparator with hysteresis requires a three-resistor network that is referenced to the comparator supply voltage (V_{CC}), as shown in Figure 1. When V_{IN} at the inverting input is less than V_T , the output voltage is high. The three network resistors can be represented as $R1//R3$ in series with $R2$. Equation 1 defines the high to low trip voltage (V_{T1}).

$$V_{T1} = \frac{R2 \cdot V_{CC}}{(R1//R3) + R2} \quad (1)$$

When V_{IN} is greater than V_A , the output voltage is low, very close to ground. In this case, the three network resistors can be presented as $R2//R3$ in series with $R1$. Equation 2 define the low to high trip voltage (V_{T2}).

$$V_{T2} = \frac{(R2//R3) \cdot V_{CC}}{(R2//R3) + R1} \quad (2)$$

The total hysteresis provided by the network is

$$\Delta V_T = V_{T1} - V_{T2} \quad (3)$$

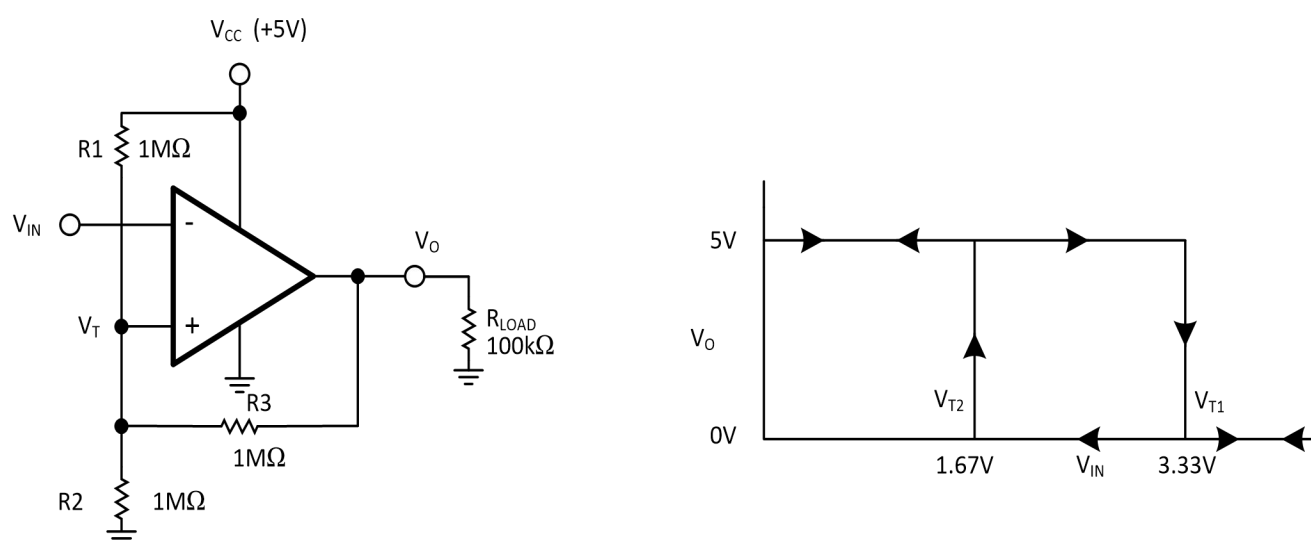

Figure 1. Inverting Configuration with Hysteresis

Non-inverting Comparator with Hysteresis

A non-inverting comparator with hysteresis requires a two-resistor network, as shown in Figure 2, and a voltage reference (V_{REF}) at the inverting input. When V_{IN} is low, the output is also low. For the output to switch from low to high, V_{IN} must rise to V_{IN1} . Equation 4 defines the low to high trip voltage (V_{IN1}):

$$V_{IN1} = \frac{(R1+R2) \cdot V_{REF}}{R2} \tag{4}$$

When V_{IN} is high, the output is also high. For the comparator to switch back to a low state, V_{IN} must drop to V_{IN2} ,

$$V_{IN2} = \frac{(R1+R2) \cdot V_{REF} - R1 \cdot V_{CC}}{R2} \tag{5}$$

The hysteresis of this circuit is the difference between V_{IN1} and V_{IN2} , as shown in following,

$$\Delta V_{IN} = V_{CC} \times \frac{R1}{R2} \tag{6}$$

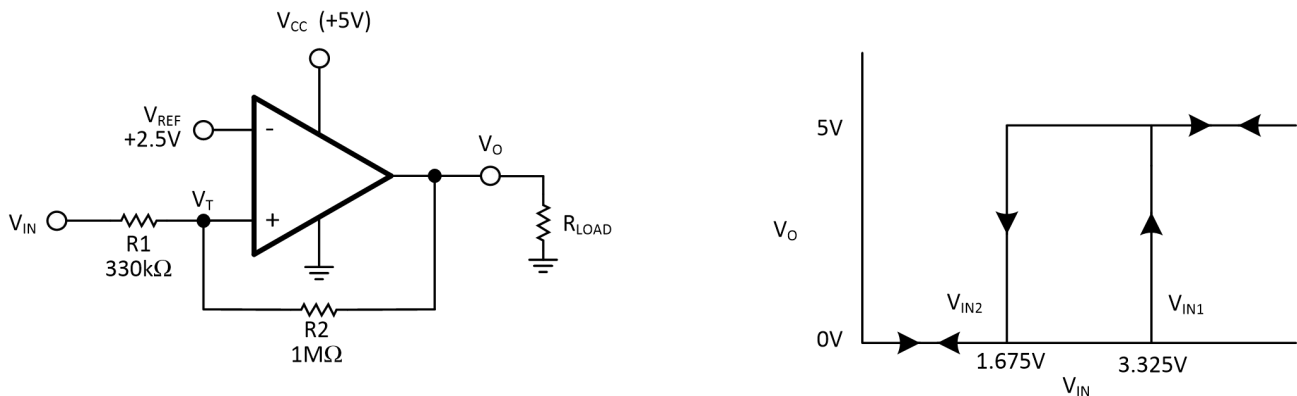

Figure 2. Non-inverting Configuration with Hysteresis

Square-Wave Oscillator

The COS3201 can be used to build a low cost square-wave oscillator as shown in Figure 3. The square-wave period is determined by the RC time constant of the capacitor ($C1$) and resistor ($R4$). The maximum frequency is limited by propagation delay of the device and the capacitance load at the output.

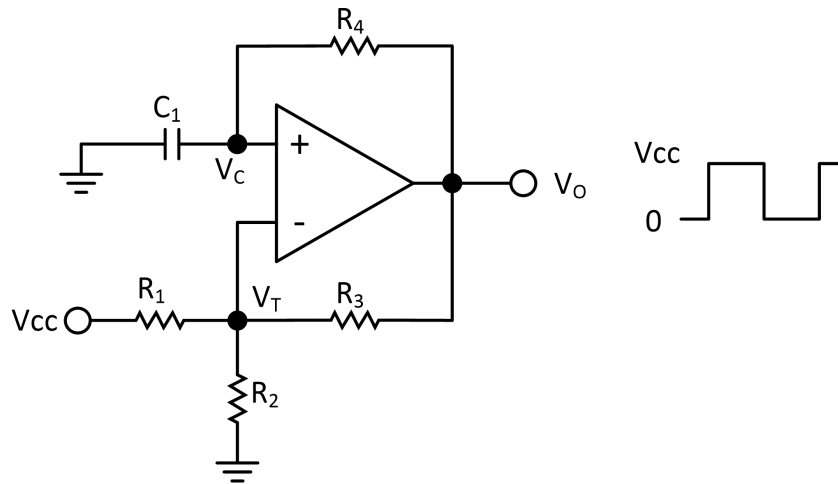

Figure 3. Square-Wave Oscillator

IR Receiver

A single COS3201 can be used to build a IR receiver analog front end as shown in Figure 4. R1 converts the IR light energy induced current into voltage and applies to the inverting input of the comparator. The RC network of R2 and C1 establishes a reference voltage Vref which tracks the mean amplitude of the IR signal. The RC constant of R2 and C1 is chosen for Vref to track the received IR current fluctuation but not the actual data bit stream. The non-inverting input is connected to Vref and the output over the R3 and R4 resistor network which provides hysteresis for improved guard against spurious toggles.

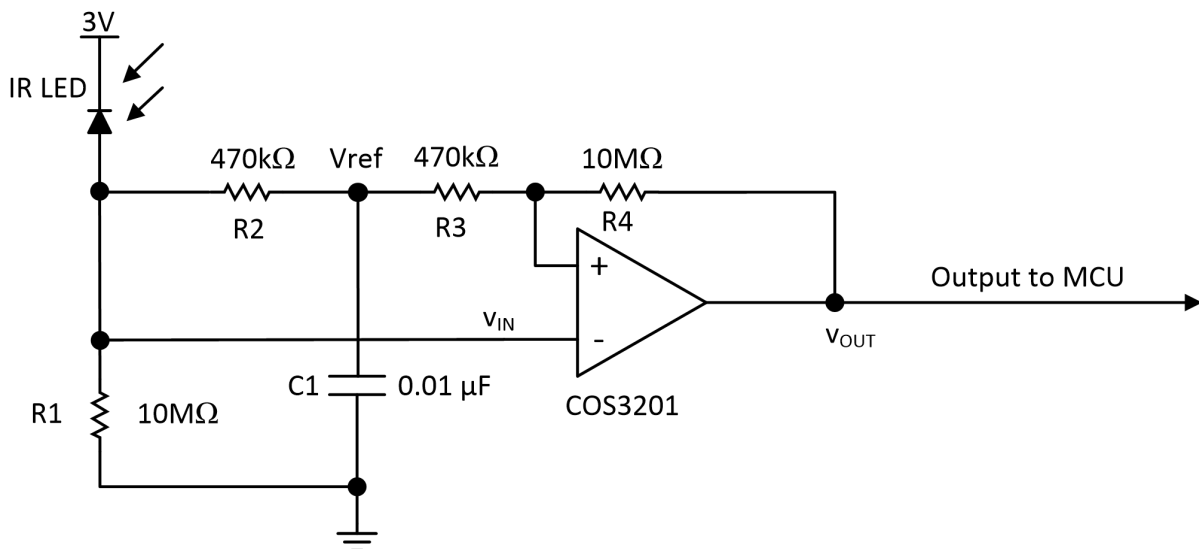

Figure 4. IR Receiver

Power-Supply Bypassing and Layout

For single-supply operation, bypass the power supply V_{cc} with a $0.1\mu\text{F}$ ceramic capacitor which should be placed close to the V_{cc} pin. For dual-supply operation, both the positive and negative supplies should be bypassed to ground with separate $0.1\mu\text{F}$ ceramic capacitors. $2.2\mu\text{F}$ tantalum capacitor can be added for better performance.

The length of the current path is directly proportional to the magnitude of parasitic inductances and thus the high frequency impedance of the path. High speed currents in an inductive ground return create an unwanted voltage noise. Broad ground plane areas will reduce the parasitic inductance. Thus a ground plane layer is important for high speed circuit design.

5. Package Information

SOT23-5 (Package Outline Dimensions)

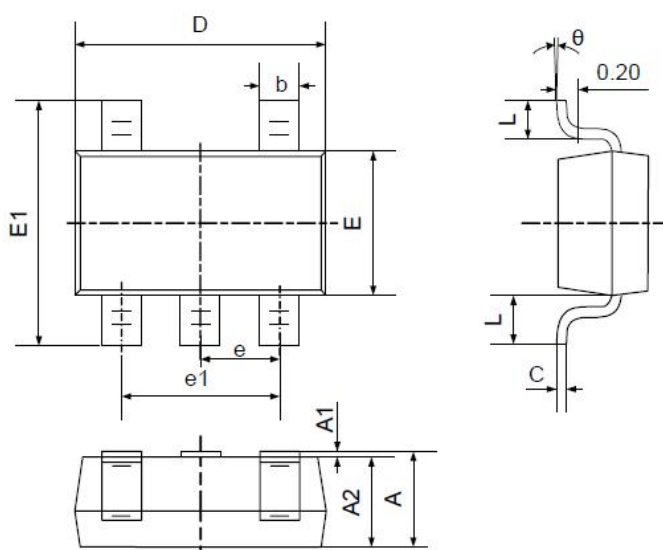

Symbol	Dimensions In Millimeters		Dimensions In Inches	
	Min	Max	Min	Max
A	1.050	1.250	0.041	0.049
A1	0.000	0.100	0.000	0.004
A2	1.050	1.150	0.041	0.045
b	0.300	0.400	0.012	0.016
c	0.100	0.200	0.004	0.008
D	2.820	3.020	0.111	0.119
E	1.500	1.700	0.059	0.067
E1	2.650	2.950	0.104	0.116
e	0.950TYP		0.037TYP	
e1	1.800	2.000	0.071	0.079
L	0.700REF		0.028REF	
L1	0.300	0.600	0.012	0.024
theta	0°	8°	0°	8°

X-ON Electronics

Largest Supplier of Electrical and Electronic Components

Click to view similar products for [Analog Comparators](#) category:

Click to view products by [COSINE](#) manufacturer:

Other Similar products are found below :

[SC2903VDR2G](#) [LM2901SNG](#) [LM339SNG](#) [NTE911](#) [LM339EDR2G](#) [NTE922](#) [NCX2200GMAZ](#) [LM2903F-E2](#) [NJM2903M-TE1](#) [MCP6544-EP](#) [MCP6541UT-I/LT](#) [MCP6542T-E/MS](#) [BA2903FVM-TR](#) [TS882IQ2T](#) [LM2901EDR2G](#) [LM2903SNG](#) [5962-8765901CA](#) [TS391SN2T1G](#) [JM38510/11201BDA](#) [LM111JG](#) [LM139ADT](#) [LM239APT](#) [TLV1704AIPW](#) [BA8391G-TR](#) [MAX9144EUD+](#) [MAX9095AUD+](#) [MIC842NYMT-T5](#) [BU7252FVM-TR](#) [NCS2200AMUT1G](#) [MAX975EUA+T](#) [MAX9034AUD+](#) [M38510/10304BGA](#) [MIC842HYMT-TR](#) [TS3021HIYLT](#) [AZV331KSTR-G1](#) [LM2901QS14-13](#) [LT1720IDD#PBF](#) [TLV7011DPWR](#) [TC75S58F,LF](#) [LT1394IS8#PBF](#) [S-89431ACMC-HBVT2U](#) [LM2903AQTH-13](#) [TLC3704MD](#) [TC75S59F,LF](#) [TC75W58FU,LF](#) [S-89431BCPH-H4DTFU](#) [TL331SN4T3G](#) [TLV7021DPWR](#) [TC75W56FU,LF](#) [LM2903QS-13](#)