

8V to 40V Low Standby Current Pulse Width Modulator (PWM) Control Circuit

Features

- 8-V to 40-V Operation
- Low Standby Current: 5.0 mA
- 5.1-V Reference Trimmed to 1%
- 100-Hz to 500kHz Oscillator Range
- Separate Oscillator Sync Terminal
- Adjustable Dead-Time Control
- Internal Soft Start
- Pulse-by-Pulse Shutdown
- Input Under-voltage Lockout With Hysteresis
- Latching PWM to Prevent Multiple Pulses
- Dual Source and Sink Output Drivers
- Available Packaging:
SOP16/TSSOP16/DIP16

Applications

- Solar Inverters
- Welding Inverters
- Motor Control
- Battery Chargers
- DC/DC Power Supplies
- Converters Using Voltage Mode

Rev1.0
 Copyright©2018 Cosine Nanoelectronics Inc. All rights reserved
 The information provided here is believed to be accurate and reliable. Cosine Nanoelectronics assumes no reliability for inaccuracies and omissions. Specifications described and contained here are subjected to change without notice on the purpose of improving the design and performance. All of this information described herein should not be implied or granted for any third party.

General Description

The COS3525A/3527A series of pulse width modulator integrated circuits are designed to offer improved performance and lowered external parts count when used in designing all types of switching power supplies. The on-chip 5.1-V reference is trimmed to 1% and the input common-mode range of the error amplifier includes the reference voltage, eliminating external resistors. A sync input to the oscillator allows multiple units to be slaved or a single unit to be synchronized to an external system clock. A single resistor between CT and the discharge terminals provides a wide range of dead-time adjustment. These devices also feature built-in soft-start circuitry with only an external timing capacitor required. A shutdown terminal controls both the soft-start circuitry and the output stages, providing instantaneous turn off through the PWM latch with pulsed shutdown, as well as soft-start recycle with longer shutdown commands.

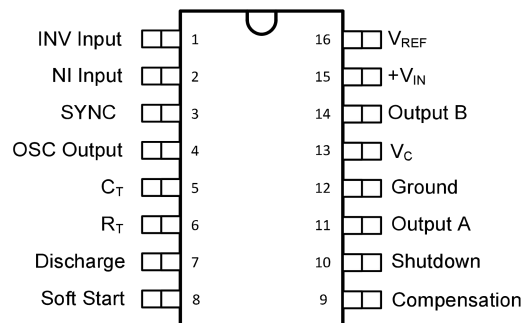

Pin Diagram

1. Pin Configuration and Block Diagram

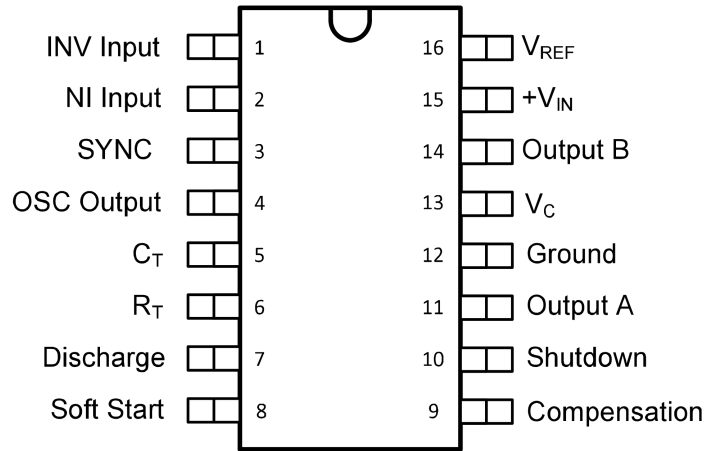

Figure 1 Pin Diagram (SOP16/TSSOP16/DIP16)

Pin Description

| Pin | Name | I/O | Description |
|-----|--------------|-----|---|
| 1 | INV Input | I | Inverting input to the error amplifier |
| 2 | NI Input | I | Non-Inverting input to the error amplifier |
| 3 | SYNC | I | Oscillator sync terminal |
| 4 | OSC Output | O | Oscillator output |
| 5 | C_T | I | Timing capacitor connection pin for oscillator frequency programming. It should be connected to the device ground using minimal trace length. |
| 6 | R_T | I | Timing resistor connection pin for oscillator frequency programming |
| 7 | Discharge | I | A single resistor between C_T and the discharge terminals provides dead-time adjustment. |
| 8 | Soft Start | I | Soft-start input pin |
| 9 | Compensation | O | Output of the error amplifier for compensation |
| 10 | Shutdown | I | Pull this pin high to shut down PWM output |
| 11 | Output A | O | Output A of the on-chip drive stage |
| 12 | Ground | P | Ground return pin |
| 13 | V_C | P | Power supply pin for the output stage. This pin should be bypassed with a 0.1- μ F ceramic low ESL capacitor with minimal trace lengths. |
| 14 | Output B | O | Output B of the on-chip drive stage |
| 15 | $+V_{IN}$ | P | Supply voltage |
| 16 | V_{REF} | O | 5.1V reference. For stability, the reference should be bypassed with a 0.1- μ F ceramic low ESL capacitor and minimal trace length to the ground plane. |

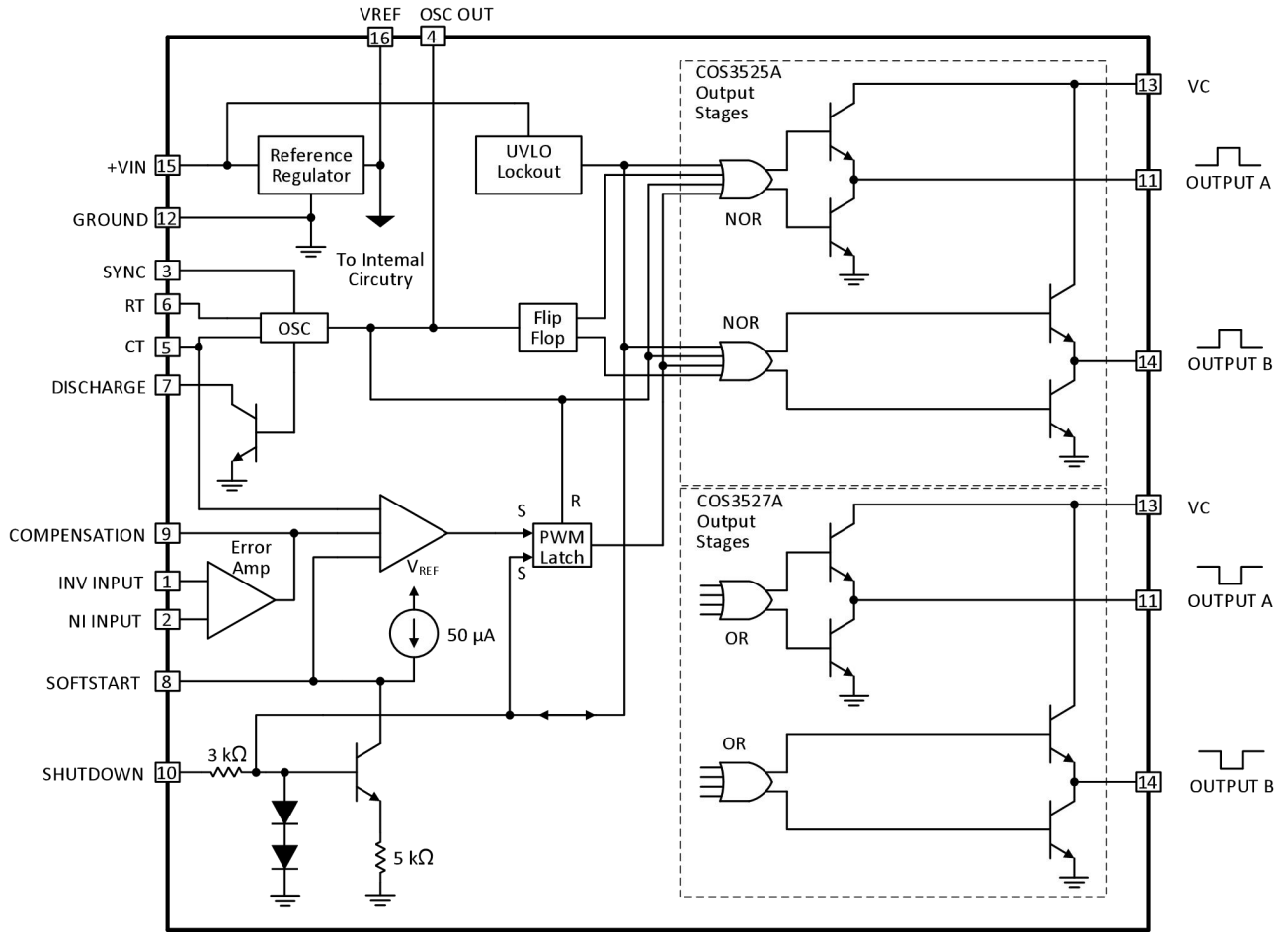

Figure 2. Block Diagram

2. Ordering Information

| Model | Order Number | Package | Package Option | Marking Information |
|----------|--------------|----------|---------------------|---------------------|
| COS3525A | COS3525AP | SOP-16 | Tape and Reel, 3000 | COS3525AP |
| | COS3525AT | TSSOP-16 | Tape and Reel, 3000 | COS3525AT |
| | COS3525AD | DIP-16 | Tube, 50 | COS3525AD |
| COS3527A | COS3527AP | SOP-16 | Tape and Reel, 3000 | COS3527AP |
| | COS3527AT | TSSOP-16 | Tape and Reel, 3000 | COS3527AT |
| | COS3527AD | DIP-16 | Tube, 50 | COS3527AD |

3. Product Specification

3.1 Absolute Maximum Ratings ⁽¹⁾

| Parameter | Min | Max | Unit |
|---|------|------------------|------|
| Supply Voltage +V _{IN} | | 41 | V |
| Collector Supply Voltage V _C | | 41 | V |
| Logic Inputs | -0.3 | 5.5 | V |
| Analog Inputs | -0.3 | +V _{IN} | V |
| Output Current, Source or Sink | | 500 | mA |
| Reference Output Current | | 50 | mA |
| Oscillator Charging Current | | 5 | mA |
| Operating Junction Temperature | -40 | +125 | °C |
| Storage Temperature | -55 | +150 | °C |

(1) Stresses exceeding the absolute maximum ratings may damage the device. The device may not function or be operable above the recommended operating conditions and stressing the parts to these levels is not recommended. In addition, extended exposure to stresses above the recommended operating conditions may affect device reliability. The absolute maximum ratings are stress ratings only.

3.2 Thermal Data

| Parameter | Rating | Unit |
|----------------------------|---|------|
| Package Thermal Resistance | 80 (SOP16) 110 (TSSOP16) 70 (DIP16) | °C/W |

3.3 Recommended Operating Conditions

| Parameter | Min. | Typ. | Max. | Unit |
|---|------|------|------|------|
| Supply Voltage +V _{IN} | 8 | - | 40 | V |
| Collector Supply Voltage V _C | 4.5 | - | 40 | V |
| Sink/Source Load Current (Steady State) | 0 | - | 100 | mA |
| Sink/Source Load Current (Peak) | 0 | - | 400 | mA |
| Reference Load Current | 0 | - | 20 | mA |
| Oscillator Frequency Range | 0.1 | - | 500 | kHz |

| | | | | |
|--------------------------------|-------|---|------|----|
| Oscillator Timing Resistor | 2 | - | 150 | kΩ |
| Oscillator Timing Capacitor | 0.001 | - | 0.01 | μF |
| Dead Time Resistor Range | 0 | - | 500 | Ω |
| Operating Junction Temperature | -40 | - | +125 | °C |

3.4 Electrical Characteristics

(Typical values are tested at $V_{IN}=20V$, $T_A=25^\circ C$, unless otherwise specified.)

| Parameter | Sym. | Conditions | Min. | Typ. | Max. | Unit |
|------------------------------|--------------------------|--|------|---------|---------|------|
| POWER SUPPLY | | | | | | |
| Supply Voltage | V_{IN} | | 8 | - | 40 | V |
| Total Standby Current | I_S | $V_{IN} = 20 V$ | - | 5 | 7 | mA |
| REFERENCE | | | | | | |
| Output Voltage | V_{REF} | | 5.0 | 5.1 | 5.2 | V |
| Line Regulation | ΔV_{REF} | $V_{IN} = 8 V \text{ to } 35 V$ | - | 10 | 20 | mV |
| Load Regulation | ΔV_{REF} | $I_L = 0 \text{ to } 20 \text{ mA}$ | - | 20 | 50 | mV |
| Temp. Stability | ΔV_{REF} | Over operating range | | 20 | 50 | mV |
| Total Output Variation | V_{REF} | Line, Load, and Temperature | 4.95 | - | 5.25 | V |
| Short Circuit Output Current | I_{SC} | $V_{REF}=0$ | - | 80 | 100 | mA |
| OSCILLATOR | | | | | | |
| Minimum Frequency | f_{MIN} | $R_T = 200 \text{ k}\Omega, C_T = 0.1 \text{ }\mu\text{F}$ | | 60 | 120 | Hz |
| Maximum Frequency | f_{MAX} | $R_T = 2 \text{ k}\Omega, C_T = 470 \text{ pF}$ | 400 | 430 | - | kHz |
| Initial Accuracy | Δf | | - | ± 2 | ± 6 | % |
| Voltage Stability | $\Delta f/\Delta V_{IN}$ | $V_{IN} = 8 V \text{ to } 35 V$ | - | ± 1 | ± 2 | % |
| Current Mirror | I_M | $I_{RT} = 2\text{mA}$ | 1.7 | 2 | 2.2 | mA |
| Clock Amplitude | V_{CLK} | | 3 | 4 | - | V |
| Clock Width | $T_{W(CLK)}$ | | 0.3 | 0.5 | 1 | μs |

| | | | | | | |
|------------------------------|----------------|--------------------------|-----|------|-----|---------|
| Sync Threshold | $V_{TH(SYNC)}$ | | 1.2 | 2 | 2.8 | V |
| Sync Input Current | $I_{I(SYNC)}$ | Sync=3.5V | - | 1 | 2.5 | mA |
| ERROR AMPLIFIER | | | | | | |
| Input Offset Voltage | V_{OS} | | | 2 | 10 | mV |
| Input Bias Current | I_B | | - | 1 | 10 | μ A |
| Input Offset Current | I_{OS} | | - | - | 1 | μ A |
| Open Loop Voltage Gain | G_{VO} | $R_L \geq 10 M\Omega$ | 60 | 80 | - | dB |
| Gain-Bandwidth Product | GBP | $A_V = 0$ dB | 1 | 2 | - | MHz |
| Common Mode Rejection Ratio | CMRR | $V_{CM} = 1.5V$ to 5.2V | 60 | 90 | - | dB |
| Power Supply Rejection Ratio | PSRR | $V_{IN} = 8V$ to 35V | 50 | 60 | - | dB |
| Low-level Output Voltage | V_{OL} | | | 0.2 | 0.5 | V |
| High-level Output Voltage | V_{OH} | | 3.8 | 5.6 | | V |
| PWM COMPARATOR | | | | | | |
| Minimum Duty Cycle | $D_{(MIN)}$ | | - | - | 0 | % |
| Maximum Duty Cycle | $D_{(MAX)}$ | | 45 | 49 | - | % |
| Input Threshold Voltage | V_{TH1} | Zero Duty Cycle | 0.7 | 0.9 | - | V |
| | V_{TH2} | Maximum Duty Cycle | - | 3.3 | 3.6 | V |
| Input Bias Current | $I_{B(COMP)}$ | | - | 0.05 | 1 | μ A |
| SOFT START | | | | | | |
| Soft Start Current | I_{SOFT} | $V_{SD}=0V, V_{SOFT}=0V$ | 25 | 50 | 80 | μ A |
| Soft Start Low Level Voltage | V_{SL} | $V_{SD}=2.5V$ | - | 0.3 | 0.7 | V |
| SHUTDOWN | | | | | | |
| Shutdown Threshold Voltage | $V_{TH(SD)}$ | $V_{SOFT}=5.1V$ | 0.6 | 0.8 | 1 | V |
| Shutdown Input Current | $I_{N(SD)}$ | $V_{SD}=2.5V$ | - | 0.3 | 1 | mA |

| | | | | | | |
|---|--------------|-------------------------------|----|-----|-----|---------|
| Shutdown Delay | $T_{D(SD)}$ | $V_{SD}=2.5V$ | - | 0.2 | 0.5 | μS |
| OUTPUT DRIVERS (each output, $V_C=20V$) | | | | | | |
| Low-level Output Voltage | $V_{DOL I}$ | $I_{SINK} = 20 \text{ mA}$ | - | 0.2 | 0.4 | V |
| | $V_{DOL II}$ | $I_{SINK} = 100 \text{ mA}$ | - | 1 | 2 | V |
| High-level Output Voltage | $V_{DOH I}$ | $I_{SOURCE} = 20 \text{ mA}$ | 18 | 19 | - | V |
| | $V_{DOH II}$ | $I_{SOURCE} = 100 \text{ mA}$ | 17 | 18 | - | V |
| Under-voltage Lockout | V_{UV} | V8 and V9 = High | 6 | 7 | 8 | V |
| Collector Leakage Current | I_{LKG} | $V_{IN}=35V$ | - | - | 200 | μA |
| Rise Time | t_R | $C_L=1nF$ | - | 80 | 600 | ns |
| Fall Time | t_F | $C_L=1nF$ | - | 70 | 300 | ns |

4. Functional Description

4.0 Overview

The COS3525A/3527A series of pulse width modulator integrated circuits are designed to offer improved performance and lowered external parts count when used in designing all types of switching power supplies. The COS3525A output stage features NOR logic, giving a LOW output for an OFF state. The COS3527A uses OR logic, which results in a HIGH output level when OFF.

4.1 Reference

The on-chip 5.1-V reference is trimmed to 1% and the input common-mode range of the error amplifier includes the reference voltage, eliminating external resistors.

4.2 Synchronized Input

A sync input to the oscillator allows multiple units to be slaved or a single unit to be synchronized to an external system clock.

4.3 Adjustable Switching Frequency and Dead-Time Control

A single resistor R_D between C_T and the discharge terminals provides a wide range of dead-time adjustment. Generally, higher switching frequency gives smaller size but have higher switching loss. The switching frequency is determined by following equation:

$$f = \frac{1}{C_T(0.7R_T + 3R_D)}$$

For example, operation at 100 kHz was selected as a reasonable compromise between size and efficiency. The value of $R_T = 10 \text{ k}\Omega$, $C_T = 1.37 \text{ nF}$ and $R_D = 100 \text{ }\Omega$ were chosen for 100-kHz oscillator frequency based on the equation.

4.4 Soft Start

These devices also feature built-in soft-start circuitry with only an external timing capacitor required. Soft start is achieved by connecting the soft-start pin to ground through a capacitor, charged by the 50uA current source.

4.5 Input Undervoltage Lockout with Hysteresis

The undervoltage lockout keeps the outputs off and the soft-start capacitor discharged for subnormal input voltage. This lockout circuitry includes approximately 500mv of hysteresis for jitter-free operation.

4.6 Shutdown Options

A shutdown terminal controls both the soft-start circuitry and the output stages, providing instantaneous turn off through the PWM latch with pulsed shutdown, as well as soft-start recycle with longer shutdown commands. Since both the compensation and soft-start terminals have current source pullups, either can readily accept a pull-down signal which only has to sink a maximum of 100uA to turn off the outputs. This is subject to the added requirement of of discharging whatever external capacitance may be attached to these pins. The shutdown pin should not be left floating as noise pickup could conceivably interrupt normal operation. All transitions of the voltage on the shutdown pin should be within the time frame of one clock cycle and not repeated at a frequency higher than 10 clock cycles.

4.7 PWM Latch

Another feature of these PWM circuits is a latch following the comparator. Once a PWM pulse has been terminated for any reason, the outputs will remain off for the duration of the period. The latch is reset with each clock pulse. T

4.8 Output Stages

The output stages are totem-pole designs capable of sourcing or sinking in excess of 200 mA. The COS525A output stage features NOR logic, giving a LOW output for an OFF state. The COS3527A uses OR logic, which results in a HIGH output level when OFF.

5. Typical Application Diagram

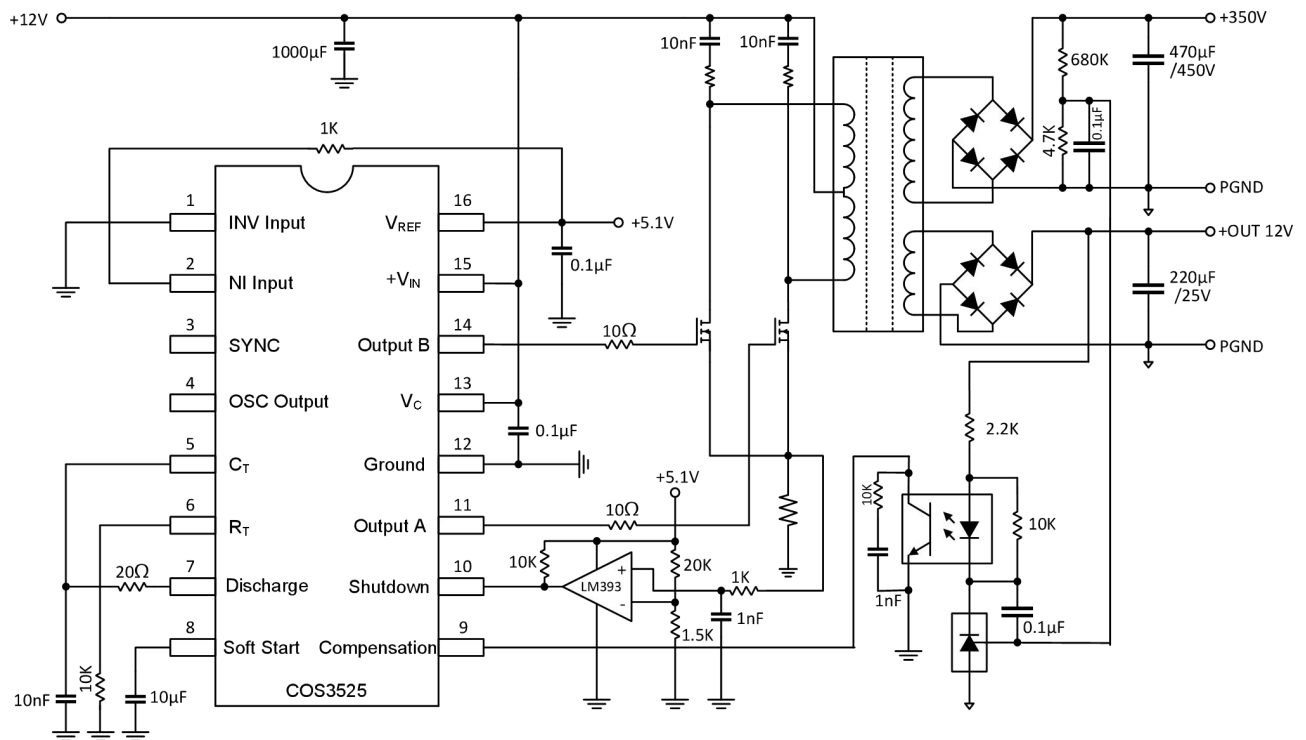
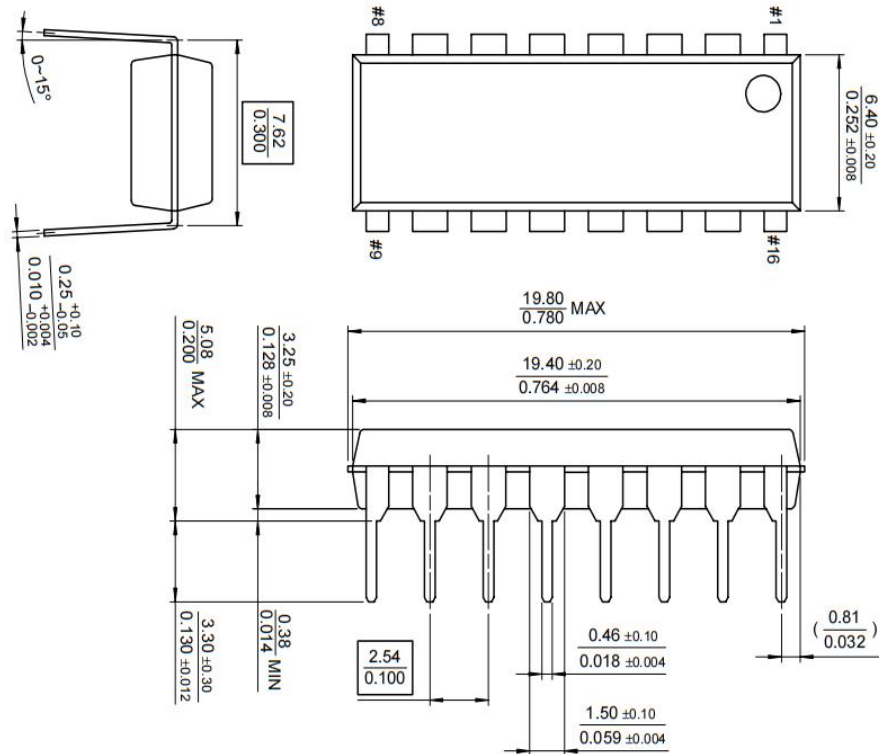

Figure 3. Typical Application in an Micro-Inverter

6. Package Information

6.1 DIP16 (Package Outline Dimensions)



6.2 SOP16 (Package Outline Dimensions)

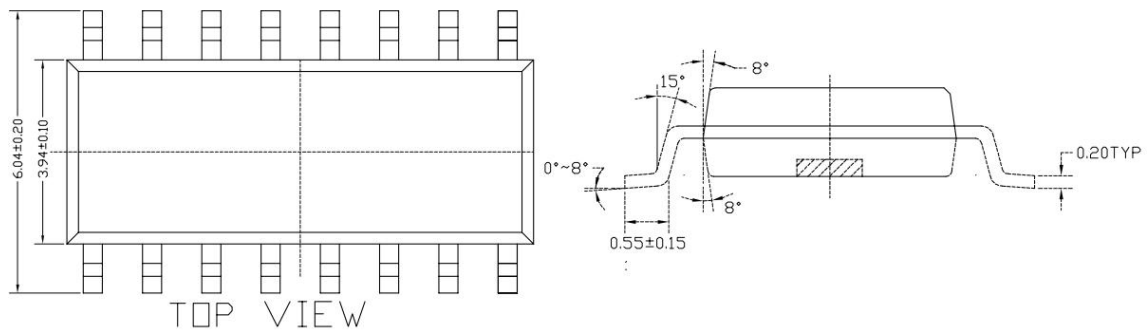

- NOTES:
1. DIMENSIONING AND TOLERANCING CONFIRM TO ASME Y14.5M-1994
 2. ALL DIMENSIONS ARE IN MILLIMETERS, ANGLES ARE IN DEGREE.
 3. UNILATERAL COPLANARITY ZONE APPLIES TO THE EXPOSED HEAT SINK SLUG AS WELL AS THE TERMINALS.
 4. ALL SPEC TAKE JEDEC MO-220 FOR REFERENCE.

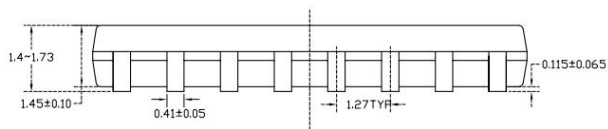

X-ON Electronics

Largest Supplier of Electrical and Electronic Components

Click to view similar products for [Switching Voltage Regulators](#) category:

Click to view products by [COSINE](#) manufacturer:

Other Similar products are found below :

[FAN53610AUC33X](#) [FAN53611AUC123X](#) [EN6310QA](#) [160215](#) [R3](#) [KE177614](#) [FAN53611AUC12X](#) [MAX809TTR](#) [AST1S31PUR](#)
[NCP81103MNTXG](#) [NCP81203PMNTXG](#) [NCP81208MNTXG](#) [PCA9412AUKZ](#) [NCP81109GMNTXG](#) [NCP81109JMNTXG](#) [MP2161AGJ-Z](#)
[NCP81241MNTXG](#) [MPQ4481GU-AEC1-P](#) [MP8756GD-P](#) [MPQ2171GJ-P](#) [MPQ2171GJ-AEC1-P](#) [MP2171GJ-P](#) [NCV1077CSTBT3G](#)
[MP28160GC-Z](#) [MPM3509GQVE-AEC1-P](#) [XDPE132G5CG000XUMA1](#) [MP5461GC-P](#) [IR3888AMTRPBFAUMA1](#) [MPQ4409GQBE-AEC1-](#)
[P](#) [S-19903DA-A8T1U7](#) [S-19903CA-A6T8U7](#) [S-19903CA-S8T1U7](#) [S-19902BA-A6T8U7](#) [S-19902CA-A6T8U7](#) [AP7361EA-SPR-13](#)
[AP7361EA-33DR-13](#) [S-19902AA-A6T8U7](#) [S-19903AA-A6T8U7](#) [S-19902AA-S8T1U7](#) [S-19902BA-A8T1U7](#) [AU8310](#) [LMR36503R5RPER](#)
[LMR36503RFRPER](#) [LMR54406DBVR](#) [XC9110C301MR-G](#) [XC9141A50CMR-G](#) [XCL206F083CR-G](#) [XCL210A111GR-G](#)
[LTM4663EV#PBF](#) [LD5537B1GL](#)