

1.5A Dual High-Speed Power MOSFET Drivers

Features

- High Peak Output Current: 1.5A
- Wide Supply Voltage Operating Range: 4.5V to 25V
- High Capacitive Load Drive Capability 1000pF in 11ns (typical)
- Short Delay Times: 35ns (typical)
- Matched Rise/Fall Times
- Low Output Impedance
- Low Supply Current
- Over-temperature Protection
- Under-voltage Lockout
- Non-overlapped Drive Tech
- ESD Protected: 2.0kV
- Input withstands negative inputs up to 5V
- Available in Green SOP8, DIP8 and DFN8 Packages

Applications

- Wireless Power Transmitter
- Switch Mode Power Supplies
- Power MOSFET Drivers
- Pulse Transformer Drivers
- Line Drivers
- CCD Driver
- Class D Switching Amplifiers

General Description

The COS4426/7/8 are matched dual power MOSFET drivers. Unique circuit design enables high speed operation capable of delivering peak currents of 1.5A into 1000pF capacitive loads. Improved speed and drive capability are enhanced by matched rise and fall delay times. These matched delays maintain the integrity of input-to-output pulse-widths to reduce timing errors and clock skew problems. Dynamic switching losses are minimized with non-overlapped drive techniques. These devices are highly latch-up resistant within their power and voltage ratings. They are not subject to damage when up to 5V of noise spiking (of either polarity) occurs on the ground pin. All terminals are fully protected against Electrostatic Discharge (ESD) up to 2.0 kV.

Pin Configuration

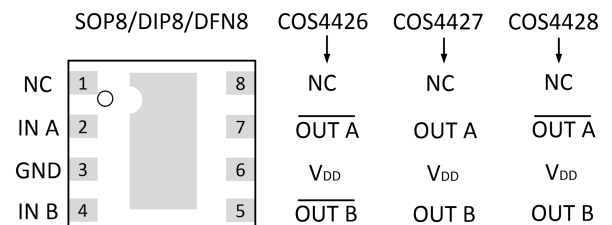

- COS4426: Outputs out of phase with inputs
- COS4427: Outputs in phase with inputs
- COS4428: OutputA: out of phase with input A
OutputB in phase with input A

Rev1.2
 Copyright©2022 Cosine Nanoelectronics Inc. All rights reserved
 The Information provided here is believed to be accurate and reliable. Cosine Nanoelectronics assumes no reliability for inaccuracies and omissions. Specifications described and contained here are subjected to change without notice on the purpose of improving the design and performance. All of this information described herein should not be implied or granted for any third party.

1. Pin Configuration and Functions

	SOP8/DIP8/DFN8	COS4426	COS4427	COS4428
NC	1	NC	NC	NC
IN A	2	$\overline{\text{OUT A}}$	OUT A	$\overline{\text{OUT A}}$
GND	3	V _{DD}	V _{DD}	V _{DD}
IN B	4	$\overline{\text{OUT B}}$	OUT B	OUT B

COS4426: Outputs out of phase with inputs

COS4427: Outputs in phase with inputs

COS4428: Output A: out of phase with input A;
Output B: in phase with input A

Figure 1. Pin Diagram

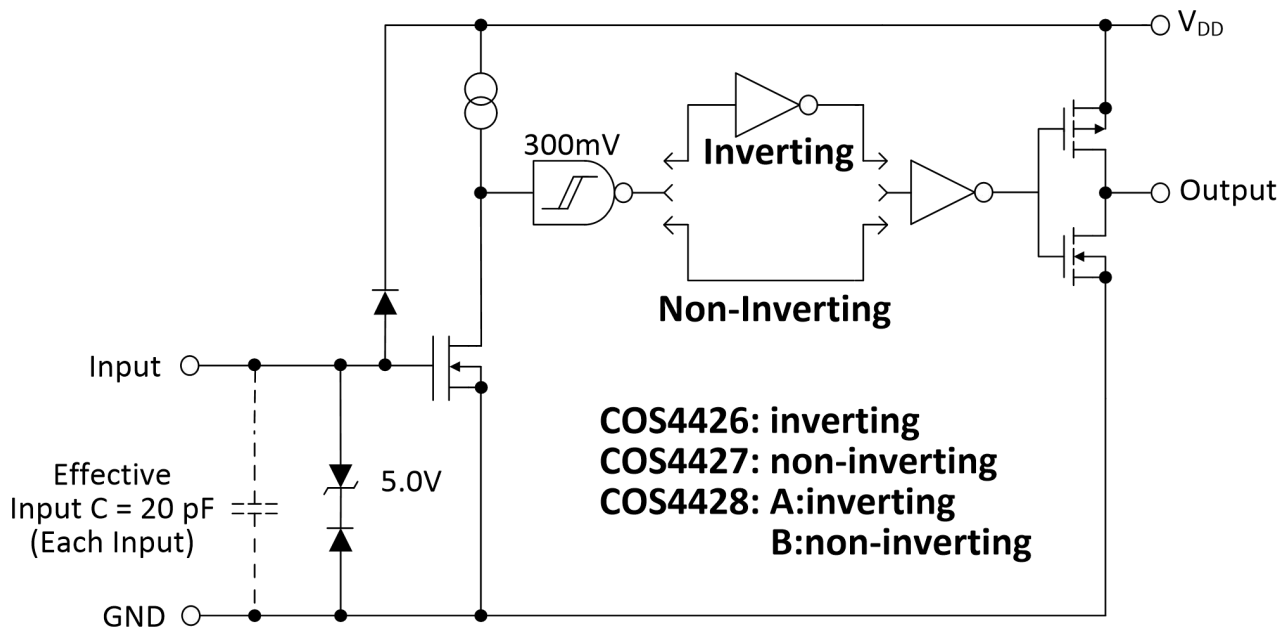

Figure 2. Functional Block Diagram

Pin Description

Pin	Name	Description
1	NC	No connection
2	IN A	Input A
3	GND	Ground
4	In B	Input B
5	OUT B	Output of Channel B
6	VDD	Power Supply
7	OUT A	Output of Channel A
8	NC	No connection
-	PAD	Exposed Metal Pad

Function Table

		COS4426		COS4427		COS4428	
INA	INB	$\overline{\text{OUTA}}$	$\overline{\text{OUTB}}$	OUTA	OUTB	$\overline{\text{OUTA}}$	OUTB
L	L	H	H	L	L	H	L
L	H	H	L	L	H	H	H
H	L	L	H	H	L	L	L
H	H	L	L	H	H	L	H

1.1 Inputs A and B

MOSFET driver inputs A and B are high-impedance, TTL/CMOS compatible inputs. These inputs also have 300 mV of hysteresis between the high and low thresholds that prevents output glitching even when the rise and fall time of the input signal is very slow.

1.2 Ground (GND)

Ground is the device return pin. The Ground pin(s) should have a low-impedance connection to the bias supply source return. High peak current flows out the Ground pin(s) when the capacitive load is being discharged.

1.3 Output A and B

MOSFET driver outputs A and B are low-impedance, CMOS push-pull style outputs. The pull-down and pullup devices are of equal strength, making the rise and fall times equivalent.

1.4 Supply Input (V_{DD})

The VDD input is the bias supply for the MOSFET driver and is rated for 4.5V to 25V with respect to the Ground pin. The VDD input should be bypassed with local ceramic capacitors. The value of these capacitors should be chosen based on the capacitive load that is being driven. A value of 1.0 μ F is suggested.

1.5 Exposed Metal Pad

The exposed metal pad of the DFN-8 package is not internally connected to any potential. Therefore, this pad can be connected to a ground plane or other copper plane on a Printed Circuit Board (PCB), to aid in heat removal from the package.

2. Product Specification

2.1 Absolute Maximum Ratings ⁽¹⁾

Parameter	Min	Max	Unit
DC supply voltage V_s		26	V
Operating junction temperature	-40	125	$^{\circ}$ C
Storage temperature	-55	150	$^{\circ}$ C
Maximum input voltage	GND-5	$V_{DD}+0.3$	V
Combined peak output current		4	A

(1) Stresses exceeding the absolute maximum ratings may damage the device. The device may not function or be operable above the recommended operating conditions and stressing the parts to these levels is not recommended. In addition, extended exposure to stresses above the recommended operating conditions may affect device reliability. The absolute maximum ratings are stress ratings only.

2.2 Thermal Data

Parameter	Rating	Unit
Package Thermal Resistance	155 (SOP8) 90 (DIP8) 57 (FDN8,3x3)	$^{\circ}$ C/W

2.3 Recommended Operating Conditions

Parameter	Rating	Unit
DC Supply Voltage	4.5V ~ 25V	V
Operating ambient temperature	-40 to +85	$^{\circ}$ C

2.4 Electrical Characteristics

(Typical values are tested at $T_A=25\text{ }^\circ\text{C}$, $V_{DD}=18\text{V}$)

Parameter	Symbol	Conditions	Min.	Typ.	Max.	Unit
INPUT						
Input Signal High Threshold	V_{IH}		1.8			V
Input Signal Low Threshold	V_{IL}				0.7	V
Input Signal Hysteresis	V_{HYS}			0.3		V
Input Current	I_{IN}	$0\text{V} \leq V_{IN} \leq V_{DD}$			± 1	μA
OUTPUT						
Pull-Up Resistance	R_{OH}	Source Current = 10mA		2.0		Ω
Pull-Down Resistance	R_{OL}	Sink Current = -10mA		2.0		Ω
Peak Output Current	I_{PK}	Source Current, $f=1\text{kHz}$, $C_L=1000\text{pF}$		1.5		A
		Sink Current, $f=1\text{kHz}$, $C_L=1000\text{pF}$		-1.5		
Continuous Output Current	I_{DC}	Source / Sink Current		± 200		mA
POWER SUPPLY						
Power Supply Current	I_{CC}	$V_{INA}=V_{INB}=3\text{V}$		0.9		mA
		$V_{INA}=V_{INB}=0\text{V}$		0.5		
Operating Voltage Range	V_{DD}		4.5		25	V
Under-Voltage Lockout ON Threshold				3.6	4	V
Under-Voltage Lockout Hysteresis				0.5		V
SWITCHING CHARACTERISTICS						
Rise Time	t_R	$C_L=1000\text{pF}$, See Figure 3.1		11		ns
Fall Time	t_F	$C_L=1000\text{pF}$, See Figure 3.1		11		ns
Turn-On Delay Time	t_{D1}	Non-inverting Input		34		ns
		Inverting Input		44		ns
Turn-Off Delay Time	t_{D2}	Non-inverting Input		34		ns
		Inverting Input		44		ns

OVER-TEMPERATURE PROTECTION						
Thermal Shutdown Threshold				150		°C
Thermal Shutdown Threshold Hysteresis				25		°C

3.0 Application Information

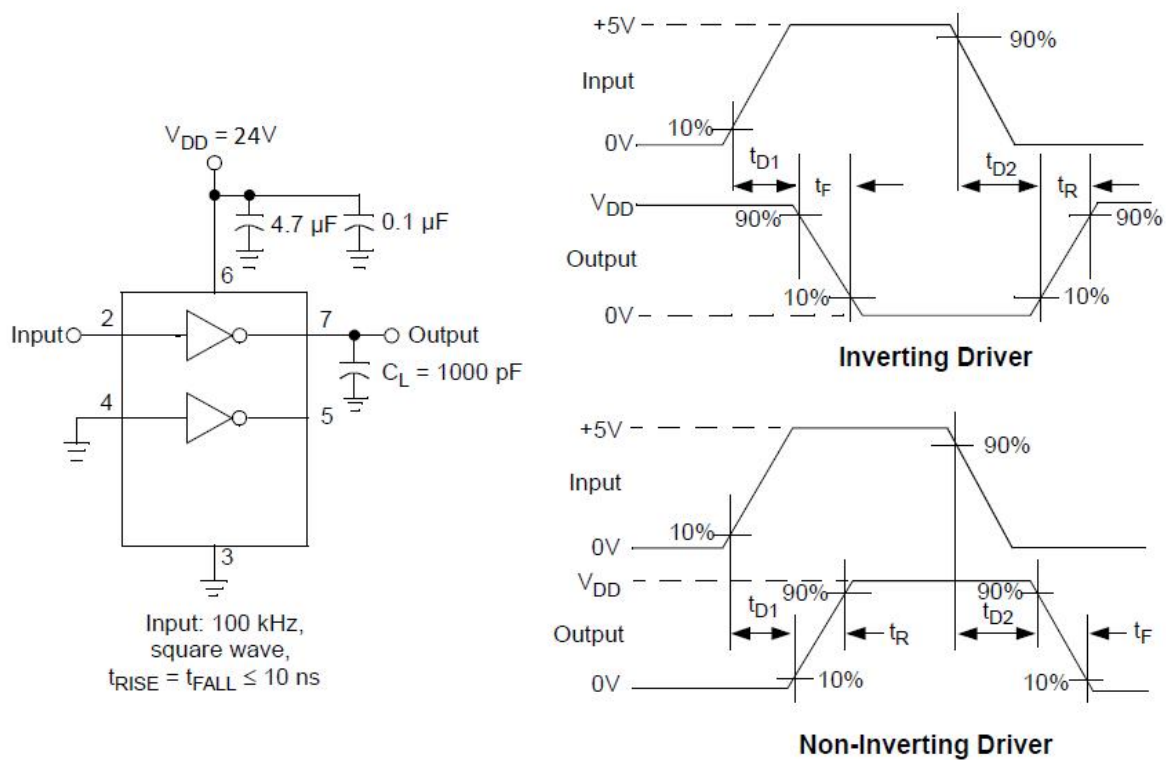
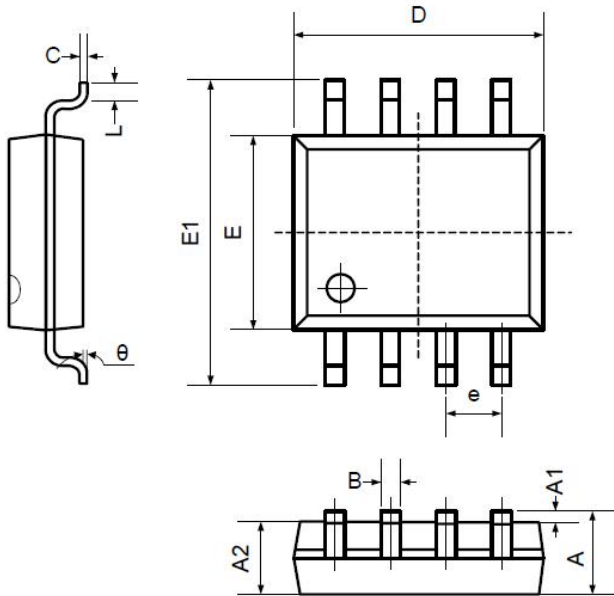

Figure 3.1 Switching Time Test Circuit

4.0 Package Information

4.1 SOP8 (Package Outline Dimensions)



Symbol	Dimensions In Millimeters		Dimensions In Inches	
	Min	Max	Min	Max
A	1.350	1.750	0.053	0.069
A1	0.100	0.250	0.004	0.010
A2	1.350	1.550	0.053	0.061
B	0.330	0.510	0.013	0.020
C	0.190	0.250	0.007	0.010
D	4.780	5.000	0.188	0.197
E	3.800	4.000	0.150	0.157
E1	5.800	6.300	0.228	0.248
e	1.270TYP		0.050TYP	
L	0.400	1.270	0.016	0.050
θ	0°	8°	0°	8°

4.3 DIP8 (Package Outline Dimensions)

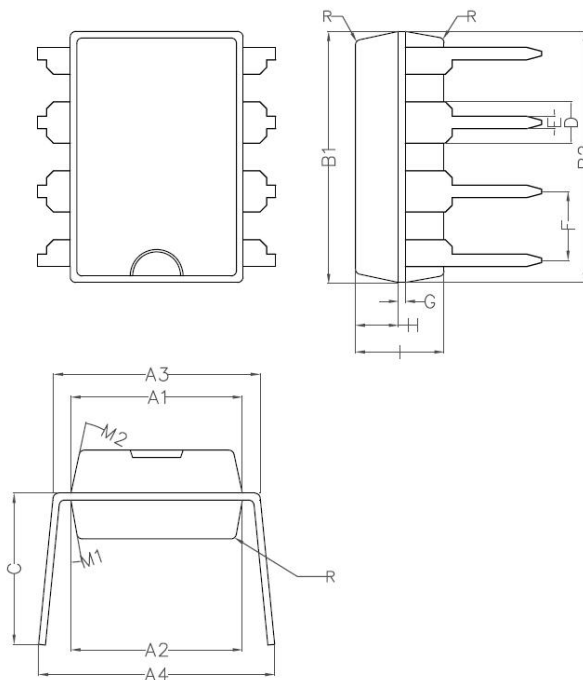

Symbol	Min	Non	Max
A1	6.28	6.33	6.38
A2	6.33	6.38	6.43
A3	7.52	7.62	7.72
A4	7.80	8.40	9.00
B1	9.15	9.20	9.25
B2	9.20	9.25	9.30
C		5.57	
D		1.52	
E	0.43	0.45	0.47
F		2.54	
G		0.25	
H	1.54	1.59	1.64
I	3.22	3.27	3.32
R		0.20	
M1	9°	10°	11°
M2	11°	12°	13°

5. Package and Ordering Information

Model	Order Number	Package	Package Option	Marking Information
COS4426	COS4426SR	SOP-8	Tape and Reel, 4000	COS4426SR
	COS4426DR	DIP-8	Tube 50	COS4426DR
COS4427	COS4427SR	SOP-8	Tape and Reel, 4000	COS4427SR
	COS4427DR	DIP-8	Tube 50	COS4427DR
COS4428	COS4428SR	SOP-8	Tape and Reel, 4000	COS4428SR
	COS4428DR	DIP-8	Tube 50	COS4428DR

X-ON Electronics

Largest Supplier of Electrical and Electronic Components

Click to view similar products for [Gate Drivers](#) category:

Click to view products by [COSINE](#) manufacturer:

Other Similar products are found below :

[00028](#) [00053P0231](#) [56956](#) [57.404.7355.5](#) [LT4936](#) [57.904.0755.0](#) [5811-0902](#) [5882900001](#) [00600P0005](#) [00-9050-LRPP](#) [00-9090-RDPP](#)
[5951900000](#) [0131700000](#) [00-2240](#) [LTP70N06](#) [LVP640](#) [5J0-1000LG-SIL](#) [LY2-US-AC240](#) [LY3-UA-DC24](#) [00576P0020](#) [00600P0010](#)
[LZN4-UA-DC12](#) [LZNQ2M-US-DC5](#) [LZNQ2-US-DC12](#) [LZP40N10](#) [00-8196-RDPP](#) [00-8274-RDPP](#) [00-8275-RDNP](#) [00-8609-RDPP](#) [00-](#)
[8722-RDPP](#) [00-8728-WHPP](#) [00-8869-RDPP](#) [00-9051-RDPP](#) [00-9091-LRPP](#) [00-9291-RDPP](#) [0207100000](#) [0207400000](#) [60100564](#) [60249-1-](#)
[CUT-TAPE](#) [0134220000](#) [60713816](#) [M15730061](#) [61161-90](#) [61278-0020](#) [6131-204-23149P](#) [6131-205-17149P](#) [6131-209-15149P](#) [6131-218-](#)
[17149P](#) [6131-220-21149P](#) [6131-260-2358P](#)