

1.2 Watt Audio Power Amplifier

Features

- 2.5V to 5.5V Operation
- 1.2W into 8Ω BTL load from 5.2V Power Supply
- THD+N=1% (typ.)
- Shutdown Current: 0.01μA (typ.)
- High PSRR
- Unity-Gain Stable
- Fast Turn-On Time
- Unity Gain Stable
- Thermal Shutdown Protection
- Operating Temperature Ranges
From -40°C to +85°C
- Available Package:
SOP-8/MSOP-8/TDFN-8

Applications

- Mobile Phones
- PDAs
- GPS
- Portable Electronic Devices

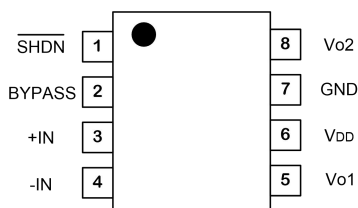

Pin Diagram

General Description

The COS4890 is a high quality audio power amplifier for portable electronic devices. It is capable of delivering 1.2 watt of continuous average power to an 8Ω BTL load with less than 1% distortion (THD+N) from a 5.2V power supply. It does not require output coupling capacitors or bootstrap capacitors, and therefore is ideally suited for mobile phone and other low voltage applications where minimal power consumption is a primary requirement.

The COS4890 is unity-gain stable and can be configured by external gain-setting resistors. It features a low-power consumption shutdown mode, which is achieved by driving the shutdown pin with logic low. Additionally, the COS4890 features an internal thermal shutdown protection mechanism.

The COS4890 contains advanced pop & click circuitry which eliminates noises that occurs during turn-on and turn-off transitions.

Rev1.0
Copyright©2018 Cosine Nanoelectronics Inc. All rights reserved

The information provided here is believed to be accurate and reliable. Cosine Nanoelectronics assumes no liability for inaccuracies and omissions. Specifications described and contained here are subjected to change without notice on the purpose of improving the design and performance. All of this information described herein should not be implied or granted for any third party.

1. Pin Configuration and Functions

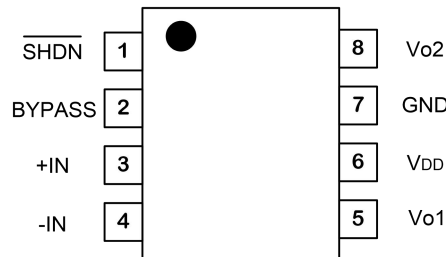

Pin Functions

Pin	Name	Description
1	SHDN	The device enters shutdown mode when a logic low is applied on this pin.
2	BYPASS	Bypass capacitor pin which provides half-supply filtering.
3	+IN	Positive input of the first amplifier, connected to the half-supply common mode voltage.
4	-IN	Negative input of the first amplifier, connected to the load and to the input resistor R_{IN} and feedback resistor R_F .
5	VO1	Negative output, connected to the load and the feedback resistor R_F .
6	VDD	Analog power supply.
7	GND	Ground
8	VO2	Positive output, connected to the load

2. Package and Ordering Information

Model	Order Number	Package	Package Option	Marking Information
COS4890	COS4890SR	SOP-8	Tape and Reel, 3000	COS4890SR
	COS4890MR	MSOP-8	Tape and Reel, 3000	COS4890MR
	COS4890TR	TDFN-8	Tape and Reel, 3000	COS4890TR

3. Product Specification

3.1 Absolute Maximum Ratings ⁽¹⁾

Parameter	Rating	Units
Power Supply: VDD to GND	6	V
Input Voltage	-0.3V to VDD+0.3	V
Storage Temperature Range	-65 to 150	°C
Junction Temperature	150	°C
Operating Temperature Range	-40 to 125	°C
ESD Susceptibility, HBM	2000	V

(1) Stresses exceeding the absolute maximum ratings may damage the device. The device may not function or be operable above the recommended operating conditions and stressing the parts to these levels is not recommended. In addition, extended exposure to stresses above the recommended operating conditions may affect device reliability. The absolute maximum ratings are stress ratings only.

3.2 Thermal Data

Parameter	Rating	Unit
Package Thermal Resistance	206 (MSOP8) 155 (SOP8)	°C/W

3.3 Recommended Operating Conditions

Parameter	Rating	Unit
DC Supply Voltage	2.5V ~ 5.5V	V
Operating ambient temperature	-40 to +85	°C

3.4 Electrical Characteristics

($V_{DD}=+5V$, $T_A=+25^{\circ}C$, $R_L=8\Omega$, unless otherwise noted)

Parameter	Symbol	Conditions	Min	Typ	Max	Unit
Quiescent Current	I_Q	$V_{IN}=0V$, no load		3.6		mA
		$V_{IN}=0V$, 8Ω load		3.8		
Shutdown Current	I_{SHDN}	$V_{shutdown}=0V$		0.01	1.0	μA
Shutdown Voltage Input High	V_{SDIH}		1.2			V
Shutdown Voltage Input Low	V_{SDIL}				0.4	V
Output Offset Voltage	V_{OS}			5	25	mV
Output Power	P_O	$V_{DD}=5.2V$, $R_L=8\Omega$, THD=1%, $f=1KHz$		1.2		W
Total Harmonic Distortion Plus Noise	THD+N	$V_{DD}=5V$, $R_L=8\Omega$, $P_O=1W$, $f=1KHz$		0.123		%
		$V_{DD}=3.6V$, $R_L=8\Omega$, $P_O=0.5W$, $f=1KHz$		0.13		
		$V_{DD}=2.5V$, $R_L=8\Omega$, $P_O=0.2W$, $f=1KHz$		0.163		
Power Supply Rejection Ratio	PSRR	$f=217Hz$		60		dB
		$f=1KHz$		68		dB
Wake up time	T_{WU}	$C_{BYPASS}=1\mu F$		140		ms

4.0 Application Notes

Internal Configuration

As shown in Figure 1, the COS4890 has two operational amplifiers internally, allowing for a few different amplifier configurations. The first amplifier's gain is externally configurable, while the second amplifier is internally fixed in a unity-gain, inverting configuration. The closed-loop gain of the first amplifier is set by selecting the ratio of R_F to R_{IN} while the second amplifier's gain is fixed by the two internal $20k\Omega$ resistors. Figure 1 shows that the output of amplifier one serves as the input to amplifier two which results in both amplifiers producing signals identical in magnitude, but out of phase by 180° . Consequently, the differential gain for the IC is

$$A_{VD} = 2 * (R_F / R_{IN})$$

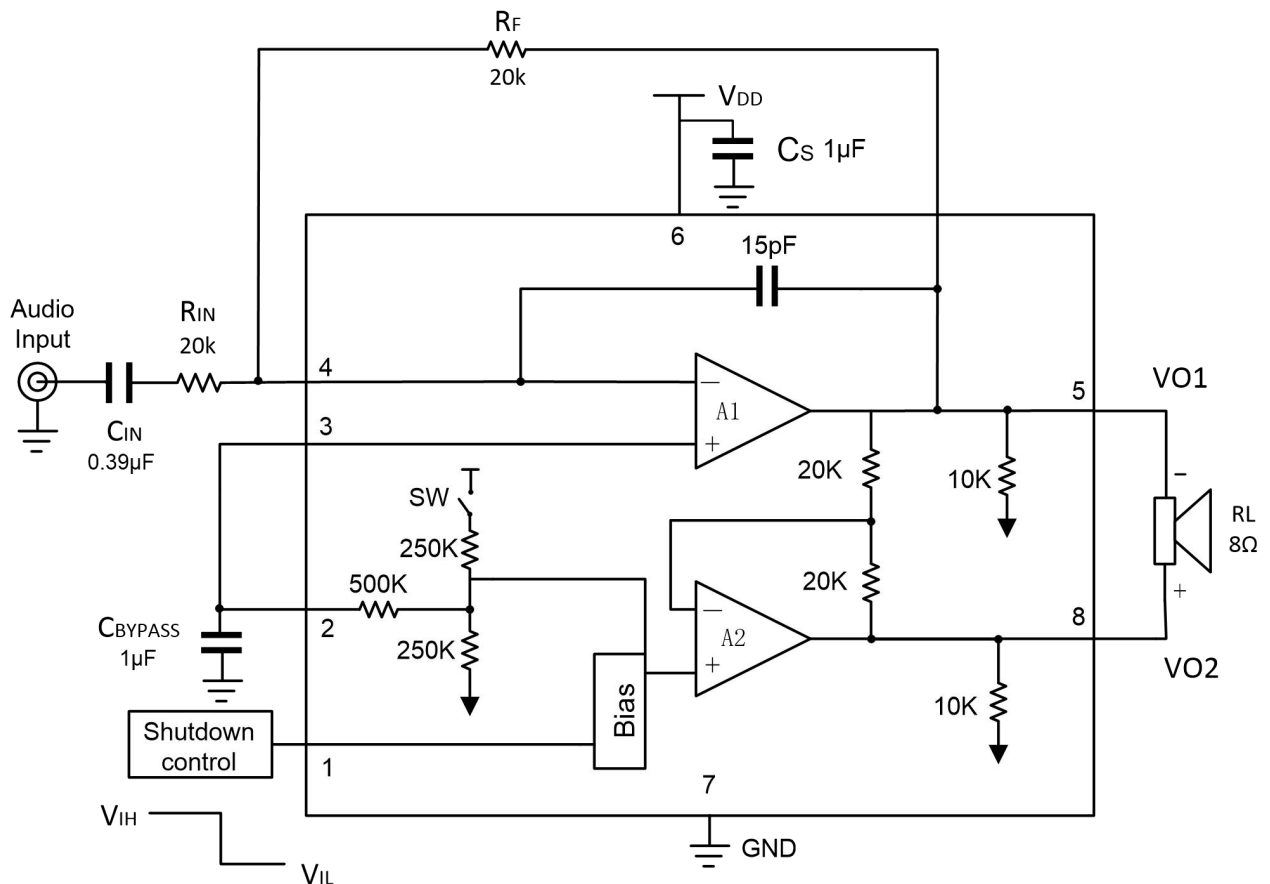

Figure 1. Internal Configuration and external components

By driving the load differentially through outputs Vo1 and Vo2, an amplifier configuration commonly referred to as “bridged mode” is established. Bridged mode operation is different from the classical single-ended amplifier configuration where one side of the load is connected to ground.

A bridge amplifier design has a few distinct advantages over the single-ended configuration, as it provides differential drive to the load, thus doubling output swing for a specified supply voltage. Four times the output power is possible as compared to a single-ended amplifier under the same conditions. This increase in attainable output power assumes that the amplifier is not current limited or clipped. A bridge configuration, also creates a second advantage over single-ended amplifiers. Since the differential outputs, Vo1 and Vo2, are biased at half-supply, no net DC voltage exists across the load. This eliminates the need for an output coupling capacitor, which is required in a single supply, single-ended amplifier configuration.

High Gain Audio Amplifier

If a closed-loop differential gain of greater than 10 is required, a feedback capacitor (C_F) may be needed as shown in Figure 2 to bandwidth limit the amplifier. This feedback capacitor creates a low pass filter that eliminates possible high frequency oscillations. Care should be taken when calculating the -3dB frequency in that an incorrect combination of R_F and C_F will cause rolloff before 20kHz. A typical combination of feedback resistor and capacitor that will not produce audio band high frequency rolloff is $R_F=20k\Omega$ and $C_F=25pf$. These components result in -3dB point of approximately 320kHz.

Differential input configuration

Figure 3. Shows a typical differential input application.

Power-Supply Bypassing and Layout

As with any amplifier, proper supply bypassing is critical for low noise performance and high power supply rejection. The capacitor location on both the bypass and power supply pins should be as close to the devices as possible.

The length of the current path is directly proportional to the magnitude of parasitic inductances and thus the high frequency impedance of the path. High frequency currents in an inductive ground return create an unwanted voltage noise. Broad ground plane areas will reduce the parasitic inductance. Thus a ground plane layer is important for high frequency circuit design.

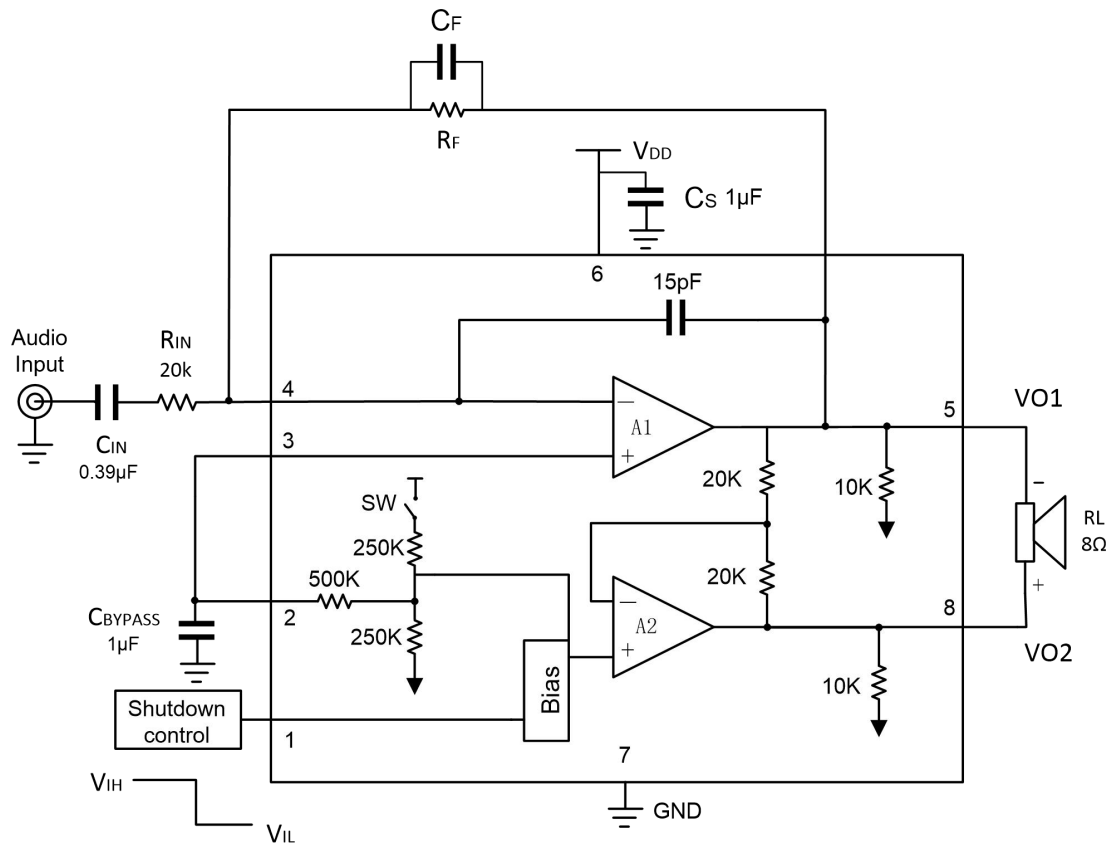

Figure 2. High Gain Application

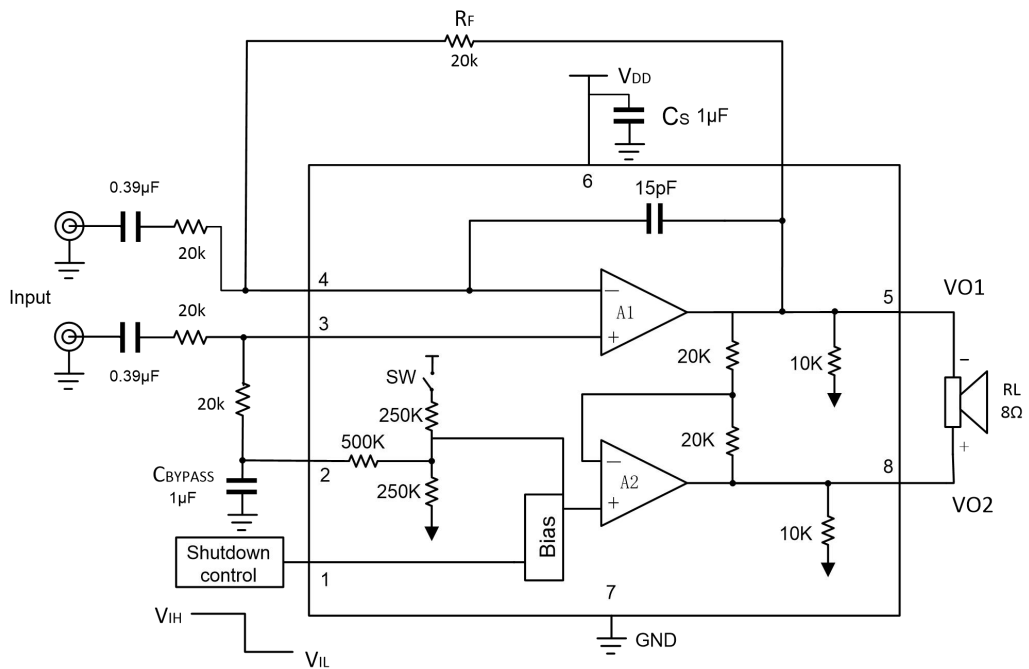
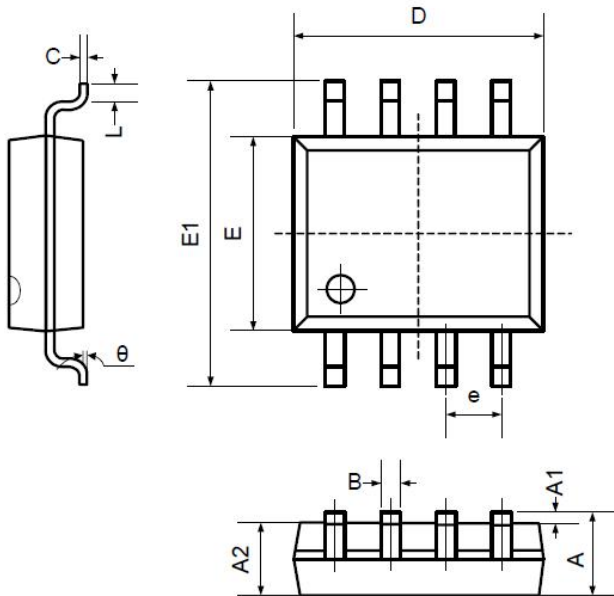

Figure 3. Differential Input Application

5. Package Information

5.1 SOP8 (Package Outline Dimensions)



Symbol	Dimensions In Millimeters		Dimensions In Inches	
	Min	Max	Min	Max
A	1.350	1.750	0.053	0.069
A1	0.100	0.250	0.004	0.010
A2	1.350	1.550	0.053	0.061
B	0.330	0.510	0.013	0.020
C	0.190	0.250	0.007	0.010
D	4.780	5.000	0.188	0.197
E	3.800	4.000	0.150	0.157
E1	5.800	6.300	0.228	0.248
e	1.270TYP		0.050TYP	
L	0.400	1.270	0.016	0.050
theta	0°	8°	0°	8°

5.2 MSOP8 (Package Outline Dimensions)

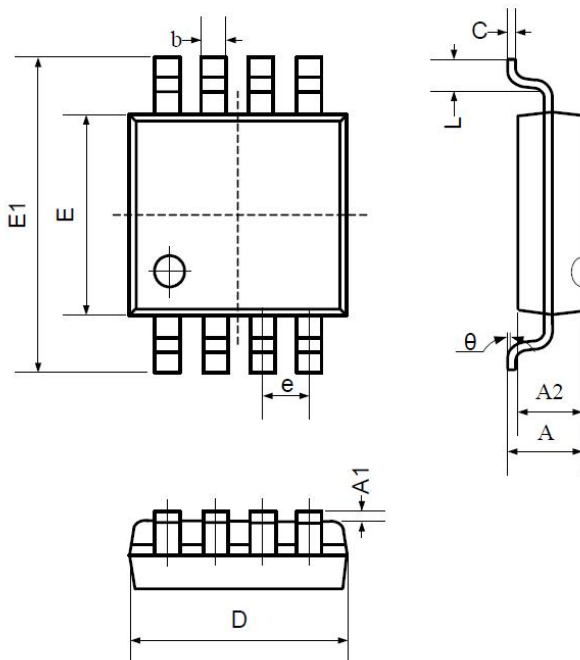

Symbol	Dimensions In Millimeters		Dimensions In Inches	
	Min	Max	Min	Max
A	0.800	1.200	0.031	0.047
A1	0.000	0.200	0.000	0.008
A2	0.760	0.970	0.030	0.038
b	0.30 TYP		0.012 TYP	
c	0.15 TYP		0.006 TYP	
D	2.900	3.100	0.114	0.122
e	0.65 TYP		0.026 TYP	
E	2.900	3.100	0.114	0.122
E1	4.700	5.100	0.185	0.201
L	0.410	0.650	0.016	0.026
theta	0°	6°	0°	6°

X-ON Electronics

Largest Supplier of Electrical and Electronic Components

Click to view similar products for [Audio Amplifiers](#) category:

Click to view products by [COSINE](#) manufacturer:

Other Similar products are found below :

[LV47002P-E](#) [AZ386MTR-E1](#) [NCP2811AFCT1G](#) [NCP2890AFCT2G](#) [IS31AP4915A-QFLS2-TR](#) [TDA1591T](#) [AS3561-BWLT-500](#)
[TDA7563AH](#) [TDA7850H](#) [TS2012EIJT](#) [NCP2809BMUTXG](#) [NJW1157BFC2](#) [TPA6201A1ZQVR](#) [IS31AP4996-GRLS2-TR](#)
[NCP2823BFCT1G](#) [LA4450L-E](#) [IS31AP2036A-CLS2-TR](#) [TDA7563ASMTR](#) [AS3561-DWLT](#) [MP1720DH-12-LF-P](#) [SABRE9601K](#)
[THAT1646W16-U](#) [PAM8965ZLA40-13](#) [TSDP10XX1NLGXZBX](#) [TSDP11XX1NBGIZBX](#) [TSDP10XX1NBGIZBX](#) [NJM4580CV-TE1](#)
[BD5638NUX-TR](#) [BD37543FS-E2](#) [BD3814FV-E2](#) [TPA3110LD2PWPR](#) [AS3435-EQFP](#) [VA2218TSG28](#) [TAS5766MRMTR](#)
[TPA3140D2PWPR](#) [TS2007EIJT](#) [IS31AP2005-DLS2-TR](#) [SSM2518CPZ-R7](#) [TAS5766MDCA](#) [TFA9879HN/N1,118](#) [AS3410-EQFP-500](#)
[FDA4100LV](#) [TPA3140D2PWP](#) [TPA6120A2RGYR](#) [BD3812F-E2](#) [MAX98400AETX+](#) [MAX98306ETD+T](#) [TS4994EIJT](#) [NCP2820FCT1G](#)
[NCP4894FCT1G](#)