

150-mW Differential Input, Stereo Audio Power Amplifier

Features

- 150-mW Stereo Output
- 2.5V to 5.5V Operation
- Dual Channel, Differential Inputs
- THD+N=0.1% (typ.)
- Shutdown Current: 0.1µA (typ.)
- Pop Reduction Circuitry
- Internal Mid-Rail Generation
- Unity Gain Stable
- Thermal Shutdown Protection
- Operating Temperature Ranges
From -40°C to +85°C
- Available Package:
MSOP-10/TDFN-10

Applications

- Mobile Phones
- PDAs
- GPS
- Portable Electronic Devices
- Notebook Computers

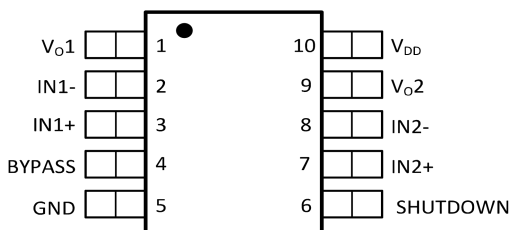

Pin Diagram

General Description

The COS6112A2 is a high quality stereo audio power amplifier for portable electronic devices. It is capable of delivering 150mW watt of continuous RMS power to an 16Ω load with less than 1% distortion (THD+N) from a 5V power supply. The COS6112A2 features dual channel with differential inputs and is ideally suited for mobile phone and other low voltage applications where minimal power consumption is a primary requirement.

The COS6112A2 is unity-gain stable and can be configured by external gain-setting resistors. It features a low-power consumption shutdown mode, which is achieved by driving the shutdown pin with logic high. Additionally, the COS6112A2 features an internal thermal shutdown protection mechanism. It also contains a pop & click reduction circuitry which eliminates noises that occurs during turn-on and turn-off transitions.

The COS6112A2 is available in a Green MSOP-10 package. It operates over an ambient temperature range of -40°C to +85°C.

Rev1.0
Copyright©2018 Cosine Nanoelectronics Inc. All rights reserved

The information provided here is believed to be accurate and reliable. Cosine Nanoelectronics assumes no reliability for inaccuracies and omissions. Specifications described and contained here are subjected to change without notice on the purpose of improving the design and performance. All of this information described herein should not be implied or granted for any third party.

1. Pin Configuration and Functions

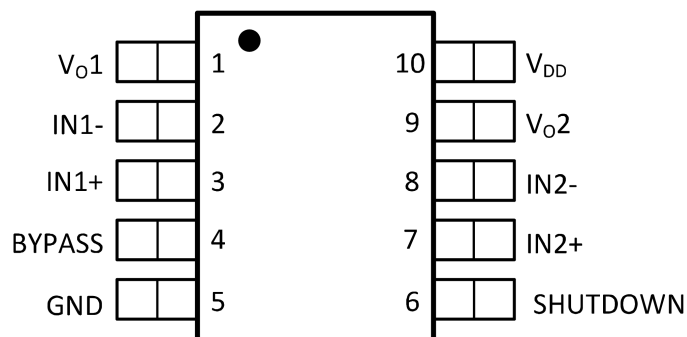

Pin Functions

Pin	Name	I/O	Description
1	Vo1	O	Vo1 is the audio output for channel 1
2	IN1-	I	Negative input for channel 1
3	IN1+	I	Positive input for channel 1
4	BYPASS	I	Tap to voltage divider for internal mid-supply bias supply. Connect to a 0.1 μ F to 1 μ F low ESR capacitor for best performance.
5	GND	P	Ground
6	SHUTDOWN	I	Puts the device in a low quiescent current mode when held high
7	IN2+	I	Positive input for channel 2
8	IN2-	I	Negative input for channel 2
9	Vo2	O	Vo2 is the audio output for channel 2
10	VDD	P	Power Supply

2. Package and Ordering Information

Model	Order Number	Package	Package Option	Marking Information
COS6112	COS6112	MSOP-10	Tape and Reel, 3000	COS6112A2

3. Product Specification

3.1 Absolute Maximum Ratings ⁽¹⁾

Parameter	Rating	Units
Power Supply: VDD to GND	6	V
Input Voltage	-0.3V to VDD+0.3	V
Storage Temperature Range	-65 to 150	°C
Junction Temperature	150	°C
Operating Temperature Range	-40 to 125	°C
ESD Susceptibility, HBM	2000	V

(1) Stresses exceeding the absolute maximum ratings may damage the device. The device may not function or be operable above the recommended operating conditions and stressing the parts to these levels is not recommended. In addition, extended exposure to stresses above the recommended operating conditions may affect device reliability. The absolute maximum ratings are stress ratings only.

3.2 Thermal Data

Parameter	Rating	Unit
Package Thermal Resistance, J _A	160 (MSOP10)	°C/W

3.3 Recommended Operating Conditions

Parameter	Rating	Unit
DC Supply Voltage	2.5V ~ 5.5V	V
Operating ambient temperature	-40 to +85	°C
High-level shutdown voltage	>60% V _{DD}	V
Low-level shutdown voltage	<25% V _{DD}	V

3.4 Electrical Characteristics

($V_{DD}=+5V$, $T_A=+25^{\circ}C$, $R_L=16\Omega$, unless otherwise noted)

Parameter	Symbol	Conditions	Min	Typ	Max	Unit	
DC Characteristic							
Quiescent Current	I_Q	$V_{IN}=0V$, $I_O=0A$	$V_{DD}=5V$		1.8	3	mA
			$V_{DD}=2.5V$		1.1	3	
Shutdown Current	I_{SHDN}	$V_{shdn}=V_{DD}$, $V_{DD}=5V$			1	μA	
Shutdown Voltage Input High	V_{SDIH}		1.8			V	
Shutdown Voltage Input Low	V_{SDIL}				0.4	V	
Output Offset Voltage	V_{OS}		-15	2	15	mV	
AC Characteristic							
Output Power (each channel)	P_O	THD=0.1%, f=1KHz	$R_L=16\Omega$, $V_{DD}=5V$		150		mW
			$R_L=32\Omega$, $V_{DD}=5V$		90		
			$R_L=16\Omega$, $V_{DD}=3.3V$		60		
			$R_L=32\Omega$, $V_{DD}=3.3V$		40		
Total Harmonic Distortion Plus Noise	THD+N	$P_O=100mW$, 20-20kHz	$R_L=16\Omega$, $V_{DD}=5V$		0.6		%
		$P_O=60mW$, 20-20kHz	$R_L=32\Omega$, $V_{DD}=5V$		0.4		
		$P_O=40mW$, 20-20kHz	$R_L=16\Omega$, $V_{DD}=3.3V$		0.4		
		$P_O=30mW$, 20-20kHz	$R_L=32\Omega$, $V_{DD}=3.3V$		0.4		
Power Supply Rejection Ratio	PSRR	f=217Hz			60		dB
		f=1KHz			68		dB
Wake up time	T_{WU}	$V_{DD}=5V$, $C_{BYPASS}=0.47\mu F$			1.8		s
Crosstalk	X_{TALK}	$V_{DD}=5V$, $R_L=32\Omega$, $P_O=60mW$, f=1kHz			-75		dB

4.0 Application Notes

Internal Configuration

As shown in Figure 1, the COS6112A2 has two differential operational amplifiers internally. The closed-loop gain of both amplifiers are set by selecting the ratio of R_F to R_I :

$$\text{Gain} = - (R_F/R_I) \quad (1)$$

For example, if the input resistance is 20 k Ω and the feedback resistor is 20 k Ω , the gain of the amplifier is -1. For high performance applications, metal-film resistors are recommended because they tend to have lower noise levels than carbon resistors. If a closed-loop differential gain of greater than 10 is required, a feedback capacitor (C_F) may be needed to bandwidth limit the amplifier. This feedback capacitor creates a low pass filter that eliminates possible high frequency oscillations. Care should be taken when calculating the -3dB frequency in that an incorrect combination of R_F and C_F will cause rolloff before 20kHz. A typical combination of feedback resistor and capacitor that will not produce audio band high frequency rolloff is $R_F=20\text{k}\Omega$ and $C_F=25\text{pf}$. These components result in -3dB point of approximately 320kHz.

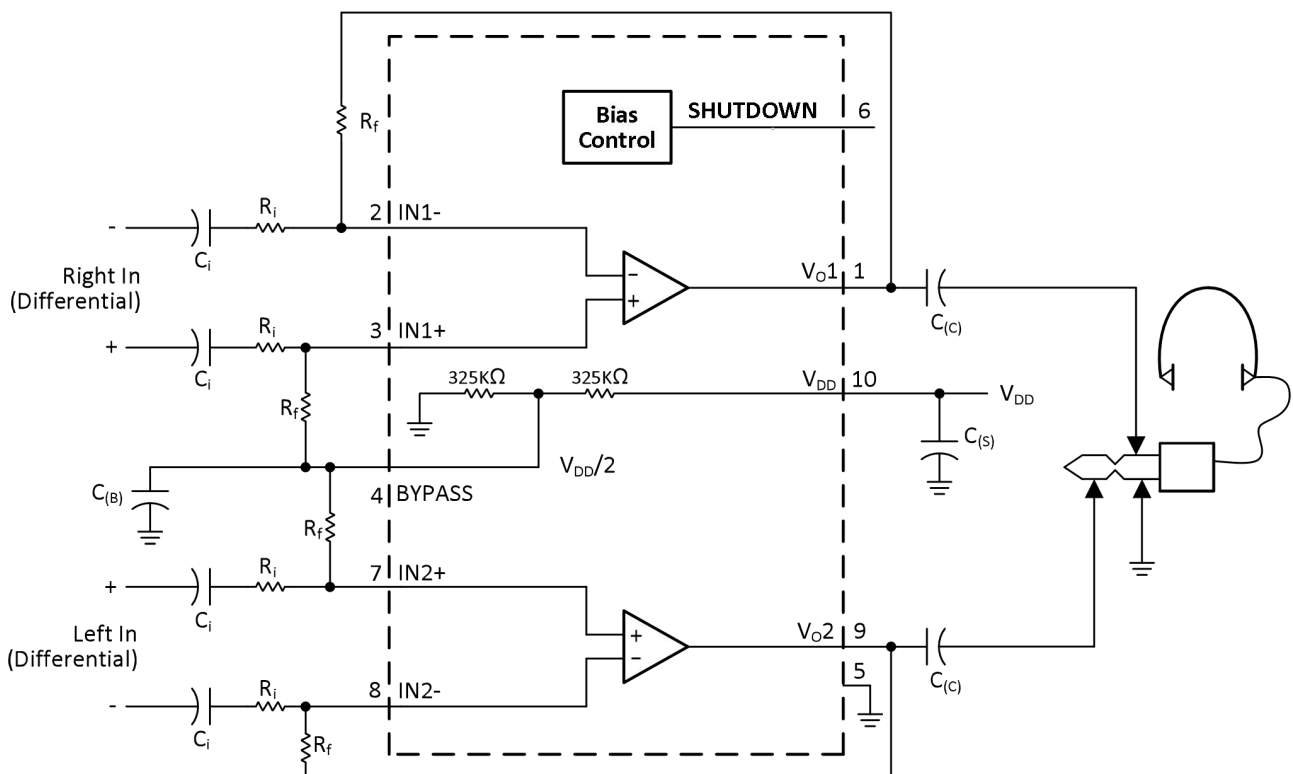

Figure 1 Typical Application Circuit

In the typical application, an input capacitor, C_i may be required to allow the amplifier to bias the input signal to the proper dc level for optimum operation. In this case, C_i and R_i form a high-pass filter with the corner frequency determined in Equation 2.

$$F_{c(\text{highpass})} = 1/(2\pi R_i C_i) \quad (2)$$

The value of C_i directly affects the bass (low frequency) performance of the circuit. Consider the example where R_i is 20 k Ω and the specification calls for a flat bass response down to 20 Hz. From Equation 2, C_i is calculated to be 0.40 μF , so one would likely choose a value in the range of 0.47 μF to 1 μF .

Power-Supply Bypassing and Layout

As with any amplifier, proper supply bypassing is critical for low noise performance and high power supply rejection. The capacitor location on both the bypass and power supply pins should be as close to the devices as possible.

The length of the current path is directly proportional to the magnitude of parasitic inductances and thus the high frequency impedance of the path. High frequency currents in an inductive ground return create an unwanted voltage noise. Broad ground plane areas will reduce the parasitic inductance. Thus a ground plane layer is important for high frequency circuit design.

5. Package Information

5.1 MSOP10 (Package Outline Dimensions)

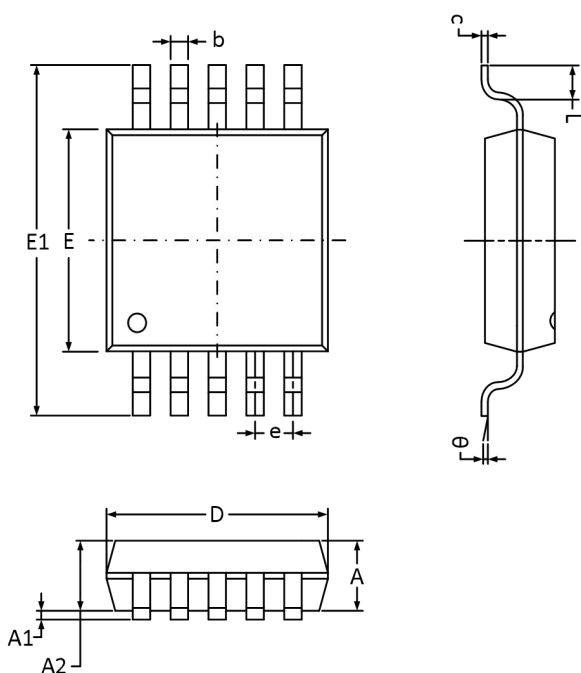

Symbol	Dimensions In Millimeters		Dimensions In Inches	
	MIN	MAX	MIN	MAX
A	0.820	1.100	0.032	0.043
A1	0.020	0.150	0.001	0.006
A2	0.750	0.950	0.030	0.037
b	0.180	0.280	0.007	0.011
c	0.090	0.230	0.004	0.009
D	2.900	3.100	0.114	0.122
E	2.900	3.100	0.114	0.122
E1	4.750	5.050	0.187	0.199
e	0.500 BSC		0.020 BSC	
L	0.400	0.800	0.016	0.031
θ	0°	6°	0°	6°

X-ON Electronics

Largest Supplier of Electrical and Electronic Components

Click to view similar products for [Audio Amplifiers](#) category:

Click to view products by [COSINE](#) manufacturer:

Other Similar products are found below :

[LV47002P-E](#) [AZ386MTR-E1](#) [NCP2890AFCT2G](#) [LC706200CM](#) [IS31AP4915A-QFLS2-TR](#) [TDA1591T](#) [TS2012EIJT](#) [NCP2809BMUTXG](#)
[NJW1157BFC2](#) [IS31AP4996-GRLS2-TR](#) [NCP2823BFCT1G](#) [BD88420GUL-E2](#) [LA4450L-E](#) [IS31AP2036A-CLS2-TR](#) [TDA7563ASMTR](#)
[BD88400GUL-E2](#) [BD88200GUL-E2](#) [SABRE9601K](#) [THAT1646W16-U](#) [PAM8965ZLA40-13](#) [TSDP10XX1NLGXZBX](#)
[TSDP11XX1NGBIZBX](#) [TSDP10XX1NGBIZBX](#) [NJM4580CV-TE1](#) [TPA3223DDVR](#) [LV4910T-MPB-E](#) [NCP2890AFCT2](#) [NCV2211DR2G](#)
[SCY99091FCT2G](#) [COS6112](#) [LM4890SS](#) [LM4871](#) [NS4890C](#) [AW8010BFCR](#) [COS4812](#) [MC34018M/TR](#) [LM4890MM/TR](#) [ME5301ASPG](#)
[LM386M-1](#) [TAS5720MRSMR](#) [BL6281GMM](#) [BL6281GSO-R](#) [BL6281GSO](#) [CS3818EO](#) [CS3817BEO](#) [CS3815EO](#) [LM4861BM/TR](#)
[TDA2822N](#) [MC34118M/TR](#) [LM4871BM/TR](#)