

8V to 40V Differential PLC Line Driver

Features

- Supply Range: 8V to 40V
- Integrated Common-mode Buffer
- Over Temperature Protection
- Large-Signal Bandwidth
- High Slew Rate
- Wide Output Swing
- Low Distortion
- Low Supply Current:
 - Full-bias mode: 23mA
 - Mod-bias mode: 18mA
 - Low-bias mode: 16mA
 - Shutdown mode: 0.2mA

Applications

- Smart Meters
- Broadband Power Line Communications
- Broadband Video Line Driver
- Home Networking PLC
- Differential DSL Line Driver

General Description

The COS6212 is a differential line-driver amplifier targeted for use in broadband power line communications (PLC) line driver applications that require high linearity while driving heavy line loads.

The integrated mid-supply common-mode buffer eliminates external components, reducing system cost and board space. The amplifier has an adjustable current pin (IADJ) that sets the nominal current consumption along with the multiple bias settings that allow for enhanced power savings where the full performance of the amplifier is not required. Shutdown bias mode provides further power savings during receive mode in time division multiplexed (TDM) systems while maintaining high output impedance.

The wide output swing of 16 V_{pp} (100Ω load) with 12-V power supplies, coupled with over 300-mA current drive (25Ω load), allows for wide dynamic range that keeps distortion minimal.

The COS6212 is available in 24-pin QFN5X4-24L and 20-pin QFN4X4-20L package with exposed thermal pad and is specified for operation from -40°C to +125°C ambient temperature.

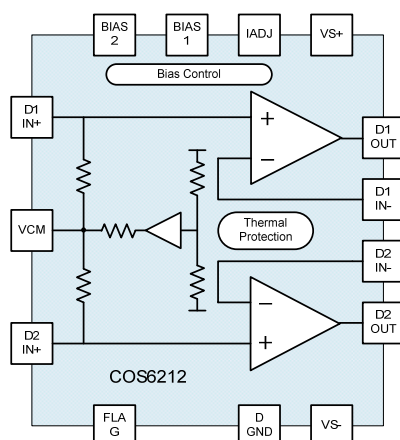

Functional Block Diagram

Rev1.1

The information provided here is believed to be accurate and reliable. Cosine Nanoelectronics assumes no liability for inaccuracies and omissions. Specifications described and contained here are subjected to change without notice on the purpose of improving the design and performance. All of this information described herein should not be implied or granted for any third party.

Cosine Nanoelectronics
www.cosine-ic.com

Copyright©2020 Cosine Nanoelectronics. All rights reserved

1. Overview

The COS6212 is a differential line-driver amplifier targeted for use in broadband power line communications (PLC) line driver applications that require high linearity while driving heavy line loads.

The integrated mid-supply common-mode buffer eliminates external components, reducing system cost and board space. The amplifier has an adjustable current pin (IADJ) that sets the nominal current consumption along with the multiple bias settings that allow for enhanced power savings where the full performance of the amplifier is not required. Shutdown bias mode provides further power savings during receive mode in time division multiplexed (TDM) systems while maintaining high output impedance.

The wide output swing of 16 Vpp (100Ω load) with 12-V power supplies, coupled with over 300-mA current drive (25Ω load), allows for wide dynamic range that keeps distortion minimal. By using 32-V power supplies and with good thermal design that keep the device within the safe operating temperature, the COS6212 is capable of swinging 58 Vpp into 100-Ω loads.

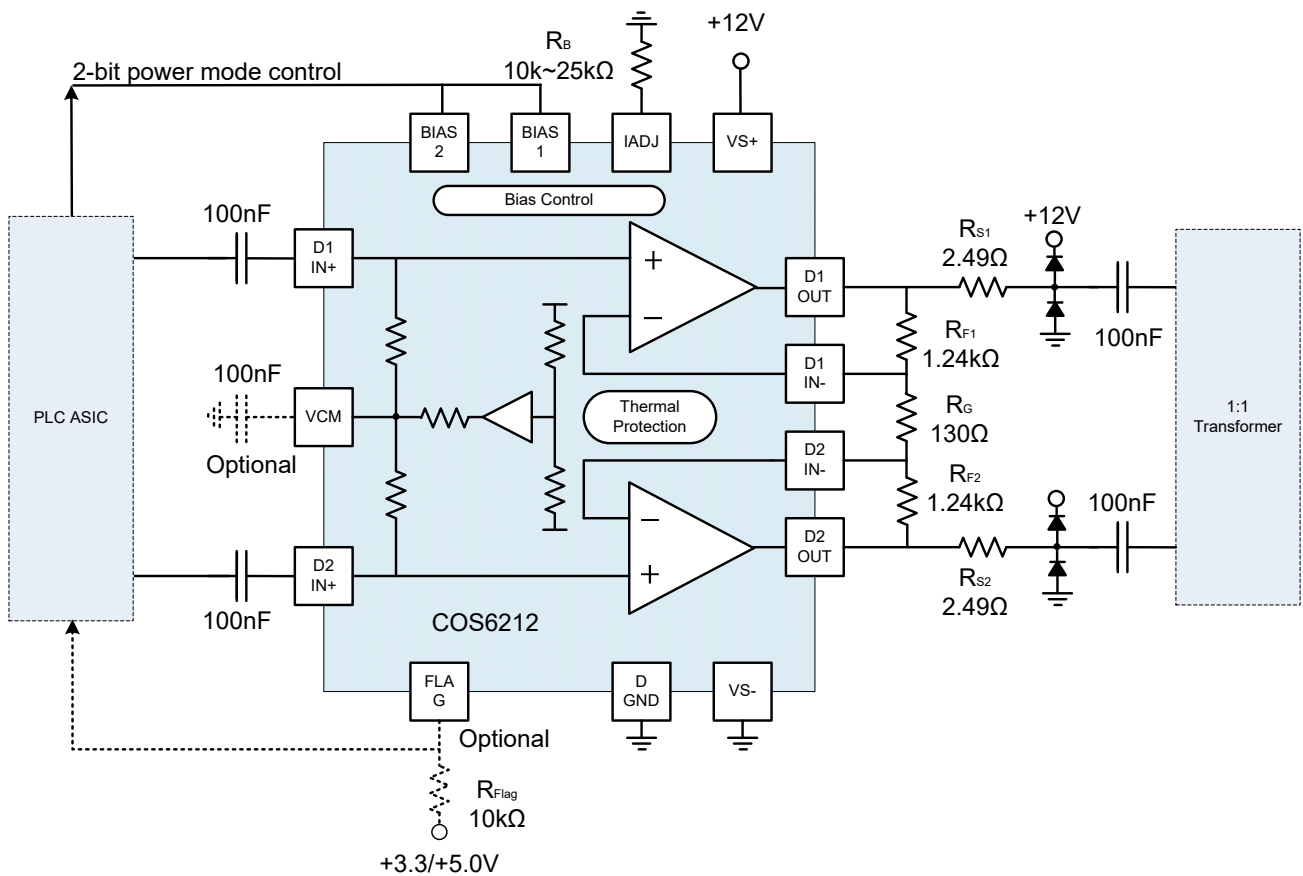

Figure1. Typical Line Driver Circuit Using the COS6212

2. Pin Configuration and Functions

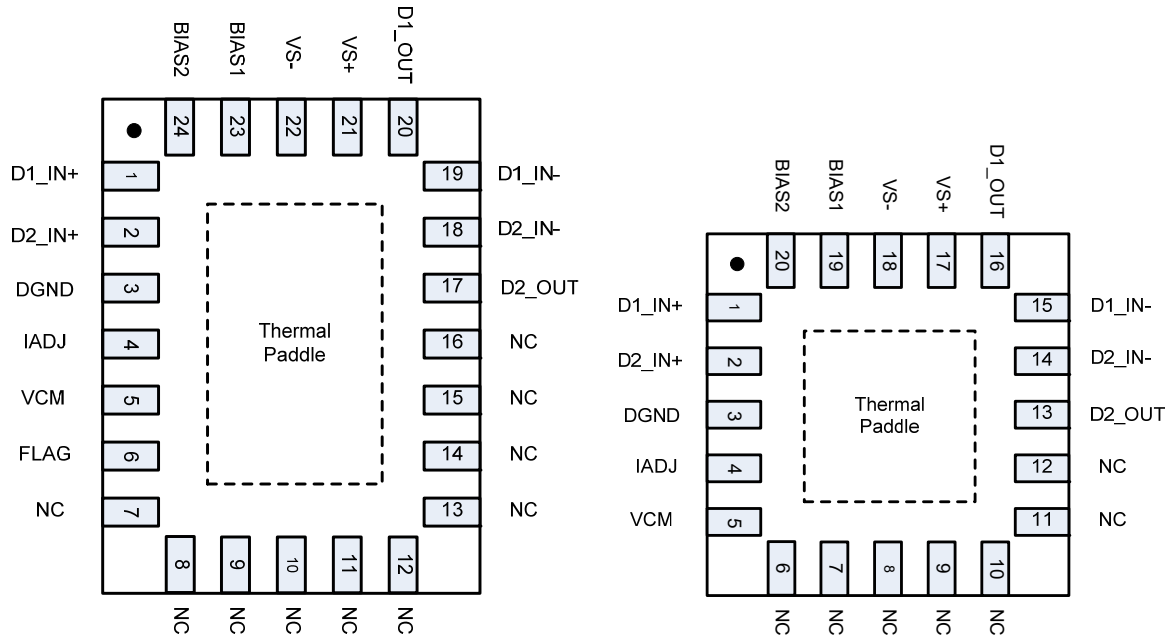

Figure 2. 24-Pin and 20-Pin QFN with Exposed Thermal Pad (Top View)

Pin Functions

Pin No. (QFN24)	Pin No. (QFN20)	Pin Name	Type	Description
1	1	D1_IN+	I	Amplifier D1 noninverting input
2	2	D2_IN+	I	Amplifier D2 noninverting input
3	3	DGND	I	Ground reference for bias control pins
4	4	IADJ	I	Bias current adjustment pin (default connect 25kΩ to Vs-)
5	5	VCM	O	Common-mode buffer output
6	-	FLAG	O	Active-low error flag output signal that indicates an output fault condition (optional).
7-16	6-12	NC	-	No connection
17	13	D2_OUT	O	Amplifier D2 output
18	14	D2_IN-	I	Amplifier D2 inverting input
19	15	D1_IN-	I	Amplifier D1 inverting input
20	16	D1_OUT	O	Amplifier D1 output
21	17	VS+	P	Positive power-supply connection
22	18	VS-	P	Negative power-supply connection
23	19	BIAS-1	I	Bias mode control, LSB
24	20	BIAS-2	I	Bias mode control, MSB

Thermal Paddle	P	Electrically connected to die substrate and VS-. Connect to VS- on the printed circuit board (PCB) for best performance.
----------------	---	--

- (1) I = input, O = output, and P = power,
- (2) NC = no internal connection.
- (3) The COS6212 defaults to the shutdown (disable) state if a signal is not present on the bias pins.
- (4) The DGND pin ranges from VS- to (VS+ - 5 V).

3. Product Specification

3.1 Absolute Maximum Ratings⁽¹⁾

Parameter	Symbol	Value	Units
Power Supply	VS+ to VS-	44	V
Storage Temperature Range	TS	-65 to 150	°C
Junction Temperature	TJ	150	°C
Operating Temperature Range	TO	-40 to 85	°C
ESD Susceptibility	HBM	5000	V

(1) Stresses exceeding the absolute maximum ratings may damage the device. The device may not function or be operable above the recommended operating conditions and stressing the parts to these levels is not recommended. In addition, extended exposure to stresses above the recommended operating conditions may affect device reliability. The absolute maximum ratings are stress ratings only.

3.2 Thermal Data

Parameter	Symbol	Value	Unit
Junction to Ambient Thermal Resistance	θ_{JA}	43.4	°C/W
Junction to Case (Bottom) Thermal Resistance	θ_{JCbot}	9.3	

3.3 Recommended Operating Conditions

Parameter	Symbol	Value	Unit
Supply Voltage	VS	8V ~ 40V	V
DGND pin voltage	DGND	VS- ~ VS+ -5	V
Operating ambient temperature	TA	-40 to +85	°C

3.4 Electrical Characteristics

(VS+=+12V, VS-=0, TA=+25°C, RL=50Ω, RF=1.24kΩ, RG=274Ω, RB=25kΩ, RS=2.49Ω, unless otherwise noted)

Parameter	Symbol	Conditions	Min	Typ	Max	Unit
Power Supply						
Operating voltage range	Vs		8	12	40	V
DGND pin voltage	DGND		Vs-	0	Vs+ -5	V
Power supply quiescent current	Iq	Full bias (BIAS1=0, BIAS2=0)		23		mA
		Mid bias (BIAS1=1, BIAS2=0)		18		
		Low bias (BIAS1=0, BIAS2=1)		16		
		Shutdown (BIAS1=1, BIAS2=1)		0.2		
Current through DGND pin		Full bias (BIAS1=0, BIAS2=0)		0.2		μA
+ Positive power supply rejection ratio	+PSRR	Differential		90		dB
- Negative power supply rejection ratio	-PSRR	Differential		90		dB
Bias Control						
Bias control pin voltage range		With respect to DGNG	0	3.3	24	V
Bias control pin logic threshold		Logic 1, with respect to DGND	1.9			V
		Logic 0, with respect to DGND			0.8	
Bias control pin current		BIAS1, BIAS2=0.5V (logic 0)		10		μA
		BIAS1, BIAS2=3.3V (logic 1)		0.26		
Open loop output impedance		Shutdown (BIAS1=1, BIAS2=1)		70 5		MΩ pF
Common-Mode Buffer Characteristics						
Common-mode offset voltage	V _{CM-OS}			±5		mV
Common-mode output resistance		DC-coupled inputs		520		Ω
		AC-coupled inputs		70		Ω

DC Performance						
Open-loop transimpedance gain	Z_{OL}			100		k Ω
Input Offset Voltage	V_{OS}	-40 to 85°C		± 2	± 50	mV
Noninverting Input Bias Current	I_{BP}			± 1		μ A
Inverting Input Bias Current	I_{BN}			± 2		μ A
Input Characteristics						
Common-Mode input Range	V_{CM}			± 3		V
Common-Mode Rejection Ratio	CMRR			70		dB
Noninverting differential input resistance				10 2		k Ω pF
Inverting input resistance				150		Ω
Output Characteristics						
Output Voltage Swing	V_o	$R_L=100\Omega, R_s=0\Omega$		± 8.8		V
		$R_L=50\Omega, R_s=0\Omega$		± 8.1		V
		$R_L=25\Omega, R_s=0\Omega$		± 7.1		V
Output Current (Sourcing and Sinking)		$R_L=25\Omega, R_s=0\Omega$		± 284		mA
Short-circuit output current				0.8		A
Dynamic Performance						
Signal bandwidth	BW	$G=5V/V, R_F=1.5k\Omega, V_o=2V_{pp}$		20		MHz
Slew rate (20% to 80%)	SR	$V_o=16V_{pp}$		500		V/ μ s
Rise and fall time (10% to 90%)		$V_o=2V_{pp}$		16		ns
1MHz harmonic distortion		$V_o=4V_{pp}, R_L=50\Omega, 2^{nd}\text{-order},$		-122		dBc
		$V_o=4V_{pp}, R_L=50\Omega, 3^{rd}\text{-order},$		-65		dBc
6MHz harmonic distortion		$V_o=4V_{pp}, R_L=50\Omega, 2^{nd}\text{-order},$		-86		dBc
		$V_o=4V_{pp}, R_L=50\Omega, 3^{rd}\text{-order},$		-56		dBc

4. Application Notes

4.1 Typical Application Circuits

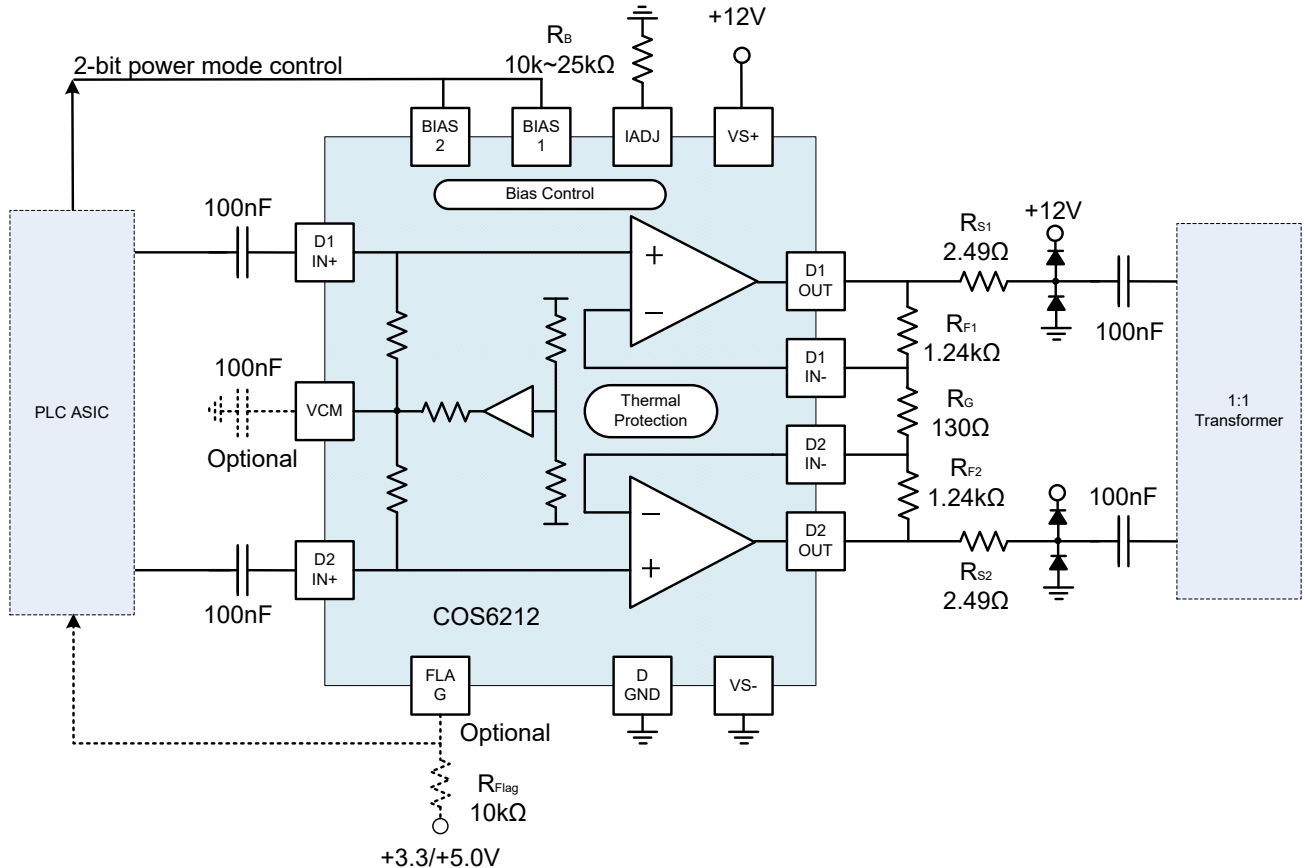

Figure 3. Typical Broadband PLC Configuration

Figure 3 shows a typical ac-coupled broadband PLC application circuit where a current-output digital-to-analog converter (DAC) of the PLC application-specific integrated circuit (ASIC) drives the inputs of the COS6212. Though Figure 1 shows the COS6212 interfacing with a current-output DAC, the COS6212 can just as easily be interfaced with a voltage-output DAC by using much larger terminating resistors, R_{T1} and R_{T2} .

The closed-loop gain equation for a differential line driver such as the COS6212 is given as

$$A_V = 1 + 2 \times (R_F / R_G)$$

where $R_F = R_{F1} = R_{F2}$. The COS6212 is a current-feedback amplifier and thus the bandwidth of the closed loop configuration is set by the value of the R_F resistor. This advantage of the current-feedback architecture allows for flexibility in setting the differential gain by choosing the value of the R_G resistor without reducing the bandwidth as is the case with voltage-feedback amplifiers.

The COS6212 is designed to provide optimal bandwidth performance with $R_{F1} = R_{F2} = 1.24 \text{ k}\Omega$. To configure the device in a gain of 20 V/V, the R_G resistor is chosen to be $130 \text{ }\Omega$. Often, a key requirement for PLC applications is the out-of-band suppression specifications. The in-band frequencies carry the encoded data with a certain power level. The line driver must not generate any spurs beyond a certain power level outside the in-band spectrum. In the design requirements of this application example, the minimum out-of-band suppression specification of 35 dB means there must be no frequency spurs in the out-of-band spectrum beyond the -80-dBm/Hz power spectral density, considering the in-band power spectral density is -50 dBm/Hz .

Table 2. Typical External Component Value

R_B	R_F	R_G	R_S	C_i	C_o
10k~25 k Ω	1.24 k Ω	130 Ω	2.49 Ω	100 nF	100 nF

4.2 Common-Mode Buffer

The COS6212 is a differential line driver that features an integrated common-mode buffer. Most common line driving applications for the COS6212 are ac-coupled applications; Therefore, the inputs must be common-mode shifted to ensure the input signals are within the common-mode specifications of the device. To maximize the dynamic range, the common-mode voltage is shifted to mid-supply in most ac-coupled applications. With the integrated common-mode buffer, no external components are required to shift the input common-mode voltage. Often, engineers choose to connect a noise-decoupling capacitor to the VCM pin. However, as shown in the common-mode voltage noise specifications, under the specified conditions and assuming the circuit is shielded from external noise sources, no difference in common-mode noise is observed with the 100-nF capacitor or without the capacitor.

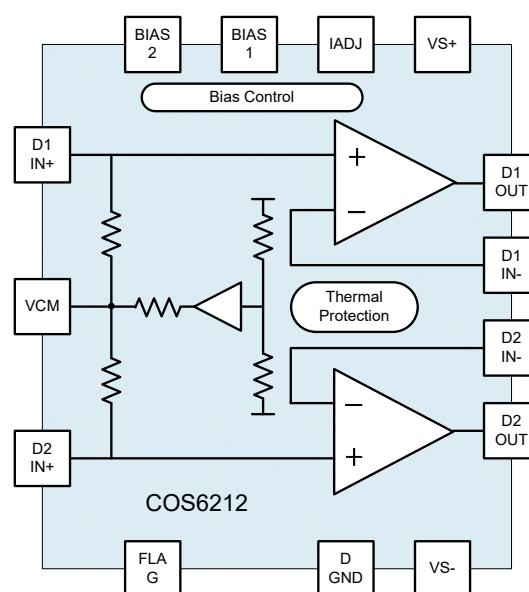

Figure 4. Functional Block Diagram

4.3 Power Saving Modes

The COS6212 has four different functional modes set by the BIAS-1 and BIAS-2 pins. Table 1 shows the truth table for the device mode pin configuration and the associated description of each mode. If the PLC application requires switching the line driver between all four power modes and if the PLC application specific integrated circuit (ASIC) has two control bits, then the two control bits can be connected to the bias pins BIAS-1 and BIAS-2 for switching between any of the four power modes. However, most PLC applications only require the line driver to switch between one of the three active power modes and the shutdown mode. This type of 1-bit power mode control is illustrated in Figure 3, where the line driver can be switched between the full-bias and shutdown modes using just one control bit from the PLC ASIC. If switching between the mid-bias or low-bias modes and the shutdown mode is required for the application, then either the BIAS-1 or BIAS-2 pin can be connected to ground and the control pin from the PLC ASIC can be connected to the non-grounded BIAS pin.

Table 1. BIAS-1 and BIAS-2 Logic Table

BIAS-1	BIAS-2	Function	Description
0	0	Full-bias mode (100%)	Amplifiers on with lowest distortion possible (default state)
1	0	Mid-bias mode (80%)	Amplifiers on with power savings and a reduction in distortion performance
0	1	Low-bias mode (75%)	Amplifiers on with enhanced power savings and a reduction of overall performance
1	1	Shutdown mode	Amplifiers off and output is high impedance

4.4 Thermal Protection

The COS6212 is designed with thermal protection that automatically puts the device in shutdown mode when the junction temperature reaches approximately 140°C. In this mode, the device behavior is the same as if the bias pins are used to power-down the device. The device resumes normal operation when the junction temperature reaches approximately 120°C. In general, the thermal shutdown condition must be avoided. If and when the thermal protection triggers, thermal cycling occurs where the device repeatedly goes in and out of thermal shutdown until the junction temperature stabilizes to a value that prevents thermal shutdown.

4.5 Error Flag

COS6212 feature an Error Flag, which signals an error condition when junction temperature exceed 140°C. The error flag is an open-collector output that pulls low under fault conditions. It can be connected to MCU for selecting an appropriate bias condition or input signal power.

5. Package Information

5.1 QFN5X4-24L (Package Outline Dimensions)

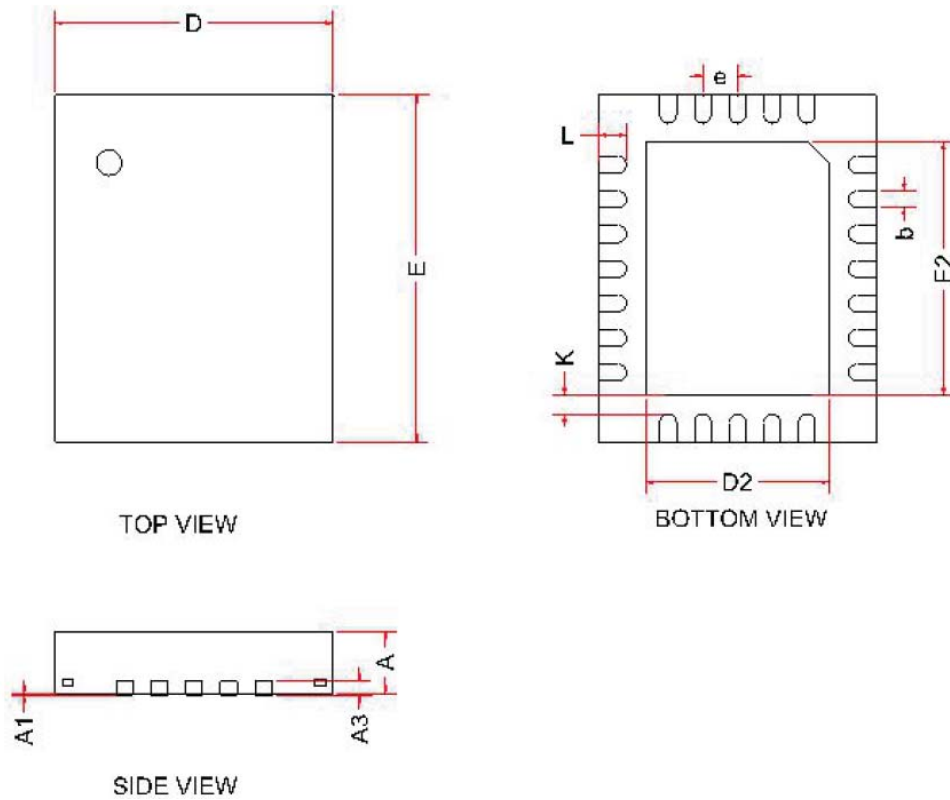

Symbol	Dimensions in Millimeters		
	Min.	Typ.	Max.
A	0.80	0.90	1.00
A1	0.00	0.02	0.05
A3	0.20Ref		
b	0.19	0.24	0.29
D	4.00BSC		
E	5.00BSC		
D2	2.50	2.65	2.75
E2	3.50	3.65	3.75
e	0.50BSC		
K	0.20	-	-
L	0.30	0.40	0.50

5.2 QFN4X4-20L (Package Outline Dimensions)

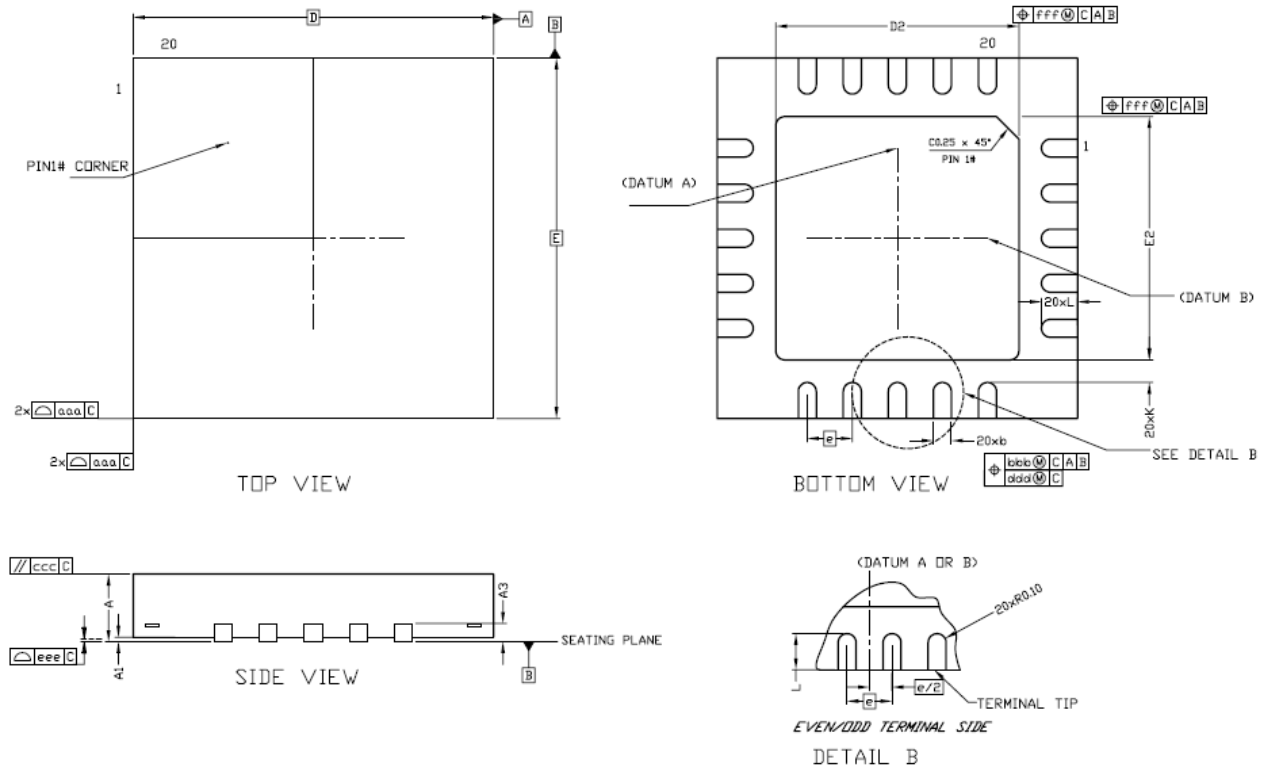

DIM SYMBOL	MIN.	NOM.	MAX.
A	0.70	0.75	0.80
	0.85	0.90	0.95
A1	0	0.02	0.05
A3	-	0.20 REF	-
b	0.15	0.20	0.25
D	4.00BSC		
E	4.00BSC		
D2	2.60	2.70	2.80
E2	2.60	2.70	2.80
e	0.50BSC		
L	0.35	0.40	0.45
K	0.20	-	-
aaa	0.10		
bbb	0.07		
ccc	0.10		
ddd	0.05		
eee	0.08		
fff	0.10		

6. Ordering Guide

Device	Package	Package Option	Marking Information
COS6212Q24R	QFN5X4-24L	Tape and Reel, 3000	COS6212Q24R
COS6212Q20R	QFN4X4-20L	Tape and Reel, 3000	COS6212Q20R

X-ON Electronics

Largest Supplier of Electrical and Electronic Components

Click to view similar products for [Differential Amplifiers](#) category:

Click to view products by [COSINE](#) manufacturer:

Other Similar products are found below :

[INA149AMDREP](#) [LT6600CS8-15#PBF](#) [LTC1992-10CMS8#PBF](#) [LT6350IDD#PBF](#) [THS4551IRGTT](#) [THS4551IRGTR](#) [AD600JN](#)
[AD626BNZ](#) [AD629ANZ](#) [AD6630ARZ](#) [AD8130ARMZ-REEL](#) [AD8131ARMZ-REEL7](#) [AD8132ARMZ-REEL7](#) [AD8137WYCPZ-R7](#)
[AD8137YCPZ-REEL7](#) [AD8139ACPZ-R2](#) [AD8139ARDZ-REEL7](#) [AD8202YRMZ-R7](#) [AD8209AWBRMZ](#) [AD8209WHRMZ](#)
[AD8271ARMZ-R7](#) [AD8276BRMZ-R7](#) [AD8350ARMZ20](#) [AD8475BRMZ](#) [AD8476ACPZ-R7](#) [AD8476ARMZ-R7](#) [AD8476BCPZ-R7](#)
[AD8147ACPZ-R2](#) [ADA4939-2YCPZ-R7](#) [AD8133ACPZ-REEL7](#) [ADA4930-2YCPZ-R7](#) [ADA4930-1YCPZ-R2](#) [ADA4932-1YCPZ-R7](#)
[ADA4937-1YCPZ-R7](#) [ADA4940-1ACPZ-R7](#) [ADA4950-2YCPZ-R7](#) [ADA4940-2ACPZ-R7](#) [AD8276ARZ-R7](#) [ADA4940-1ARZ-R7](#)
[AD628ARZ-R7](#) [AD8137YRZ-REEL](#) [AD8206YRZ-REEL7](#) [AMP03GSZ-RL](#) [AD8202YRZ](#) [AD8138ARZ-R7](#) [AD8131ARZ](#) [AD8130ARZ-](#)
[REEL7](#) [AD8130ARZ-REEL](#) [AD8131ARZ-REEL7](#) [AD8137YRZ-REEL7](#)