

# High Voltage, Differential Comparators

## Features

- Wide Supply Range:
  - Single Supply: 2V to 36V
  - Dual Supplies:  $\pm 1V$  to  $\pm 18V$
- Low Quiescent Current: 0.4mA (dual)
- Low Input Offset Voltage: 1mV (typical)
- Low Input Offset Current: 5nA (typical)
- Common Mode Input Voltage Range Includes Ground
- Differential Input Voltage Range:  $\pm 36V$
- Open-Drain Outputs
- Output Compatible with TTL, MOS and CMOS
- Packaging Available:
  - LM393 (dual): SOP8/MSOP8
  - LM339 (quad) : SOP14/TSSOP14

## Applications

- Inspection Equipment
- Threshold Detectors/Discriminators
- Peak and Zero-crossing detectors
- Logic Level Shifting or Translation
- Motor Control: AC Induction
- Sensor Conditioning
- Weight Scale

## General Description

The LM393 (dual) and LM339 (quad) are low-power, low offset voltage differential comparators operated on 2V to 36V single supply or  $\pm 1V$  to  $\pm 18V$  dual supplies. Despite their wide supply range, the LM393/339 family provides excellent overall performance and versatility. They have high differential input voltage capability. The common-mode input voltage range includes ground, enabling direct sensing near ground.

The output current drain is independent of the supply voltage. The outputs can be connected to other open-collector outputs to achieve wired-AND relationships. Input offset voltage as low as 2mV make this device family an excellent selection for many applications in consumer, automotive, and industrial electronics.

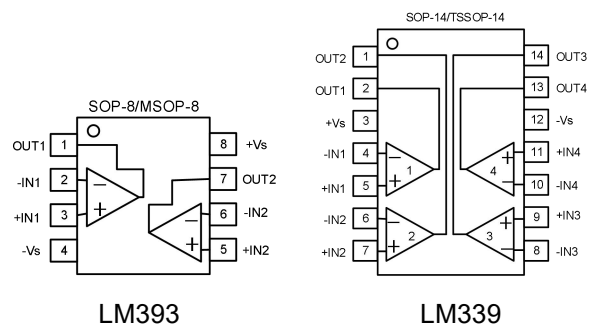

Rev1.0  
Copyright©2018 Cosine Nanoelectronics Inc. All rights reserved

The information provided here is believed to be accurate and reliable. Cosine Nanoelectronics assumes no reliability for inaccuracies and omissions. Specifications described and contained here are subjected to change without notice on the purpose of improving the design and performance. All of this information described herein should not be implied or granted for any third party.

## 1. Pin Configuration and Functions

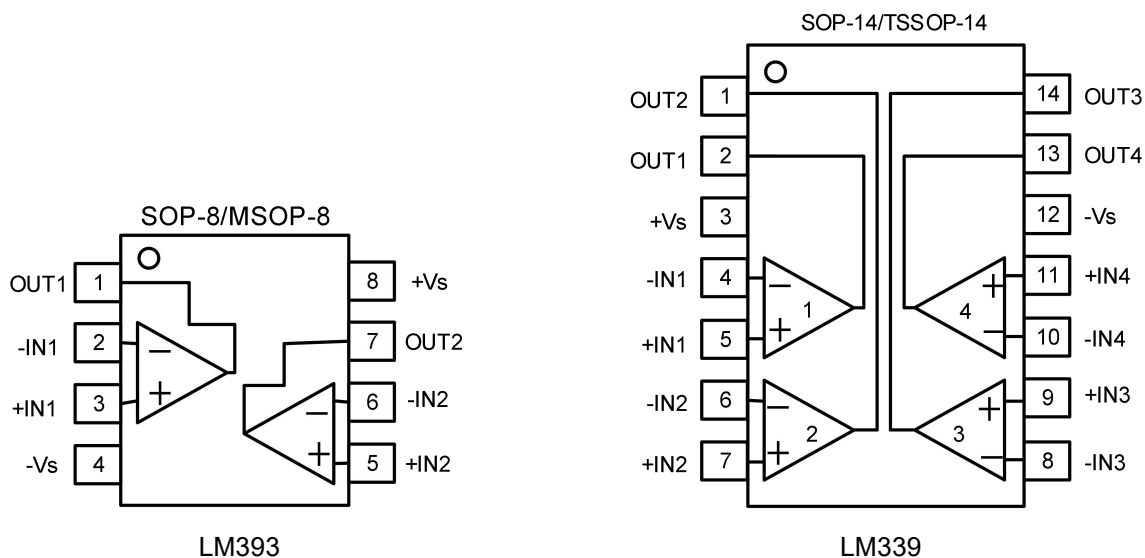

### Pin Functions

Name	Description	Note
+Vs	Positive power supply	A bypass capacitor of 0.1 $\mu$ F as close to the part as possible should be placed between power supply pins or between supply pins and ground.
-Vs	Negative power supply or ground	If it is not connected to ground, bypass it with a capacitor of 0.1 $\mu$ F as close to the part as possible.
-IN	Negative input	Inverting input of the comparator. Voltage range of this pin can go from -Vs -0.3V to +Vs + 0.3V.
+IN	Positive input	Non-inverting input of the comparator. This pin has the same voltage range as -IN.
OUT	Output	Output pin of the comparator. Connect to a load or pull-up resistor.

## 2. Package and Ordering Information

Model	Channel	Order Number	Package	Package Option	Marking Information
LM393	2	LM393SR	SOP-8	Tape and Reel, 4000	COS393
		LM393MR	MSOP-8	Tape and Reel, 4000	COS393
LM339	4	LM339SR	SOP-14	Tape and Reel, 3000	COS339
		LM339TR	TSSOP-14	Tape and Reel, 3000	COS339

### 3. Product Specification

#### 3.1 Absolute Maximum Ratings <sup>(1)</sup>

Parameter	Rating	Units
Power Supply: +Vs to -Vs	36	V
Differential Input Voltage Range	$\pm V_s$	V
Common Mode Input voltage Range <sup>(2)</sup>	-Vs to +Vs	V
Output Current	50	mA
Storage Temperature Range	-65 to 150	°C
Junction Temperature	150	°C
Operating Temperature Range	-40 to 125	°C
ESD Susceptibility, HBM	2000	V

(1) Stresses exceeding the absolute maximum ratings may damage the device. The device may not function or be operable above the recommended operating conditions and stressing the parts to these levels is not recommended. In addition, extended exposure to stresses above the recommended operating conditions may affect device reliability. The absolute maximum ratings are stress ratings only.

(2) Input terminals are diode-clamped to the power-supply rails. Input signals that can swing more than 0.5V beyond the supply rails should be current-limited to 10mA or less.

#### 3.2 Thermal Data

Parameter	Rating	Unit
Package Thermal Resistance, $R_{\theta JA}$ (Junction-to-ambient)	206 (MSOP8) 155 (SOP8) 105 (TSSOP14) 82 (SOP14)	°C/W

#### 3.3 Recommended Operating Conditions

Parameter	Rating	Unit
DC Supply Voltage	$\pm 1V \sim \pm 18V$ or $2V \sim 36V$	V
Input common-mode voltage range	$-V_s \sim +V_s - 1$	V
Operating ambient temperature	-40 to +85	°C

### 3.4 Electrical Characteristics

(+Vs=5V, -Vs=0V, TA=+25°C, unless otherwise noted)

Parameter	Symbol	Conditions	Min	Typ	Max	Unit
<b>Input Characteristics</b>						
Input Offset Voltage	V <sub>OS</sub>	T <sub>A</sub> =25°C		±1	±5	mV
		0°C to 75°C			±9	
Input Offset Current	I <sub>OS</sub>	T <sub>A</sub> =25°C		±5	±50	nA
		0°C to 75°C			±150	
Input Bias Current	I <sub>B</sub>	T <sub>A</sub> =25°C		25	250	nA
		0°C to 75°C			400	
Common-Mode Input Voltage Range	V <sub>IVR</sub>	T <sub>A</sub> =25°C	0		+Vs-1.5	V
		0°C to 75°C	0		+Vs-2.0	
Large-Signal Differential Voltage Gain	A <sub>VD</sub>	+Vs=15V, R <sub>L</sub> ≥ 15 kΩ to +Vs	50	200		V/mV
<b>Output Characteristics</b>						
High-Level Output Current	I <sub>OH</sub>	V <sub>OH</sub> =5V, V <sub>ID</sub> =1V,		0.1		nA
		V <sub>OH</sub> =30V, V <sub>ID</sub> =1V, 0°C to 75°C			1	μA
Low-Level Output Current	I <sub>OL</sub>	V <sub>OL</sub> = 1.5 V, V <sub>ID</sub> = -1 V	6	16		mA
Low-Level Output Voltage	V <sub>OL</sub>	I <sub>OL</sub> = 4 mA, V <sub>ID</sub> = -1 V		150	400	mV
		0°C to 75°C			700	
<b>Power Supply</b>						
Quiescent Current (LM393 Dual)	I <sub>Q</sub>	+V <sub>S</sub> = 5V, R <sub>L</sub> = ∞		0.4	1.0	mA
		+V <sub>S</sub> = 30V, R <sub>L</sub> = ∞			2.5	
Quiescent Current (LM339 Quad)		+V <sub>S</sub> = 5V, R <sub>L</sub> = ∞		0.8	2.0	mA
		+V <sub>S</sub> = 30V, R <sub>L</sub> = ∞			5.0	
<b>Switching Characteristics</b>						
Response Time (R <sub>L</sub> connected to 5V through 5.1 kΩ, C <sub>L</sub> = 15pF)	t <sub>RES</sub>	100mV input step with 5mV overdrive		1.3		μs
		TTL-level input step		0.3		

## 4.0 Application Notes

The LM393 (dual) and LM339 (quad) family operates as voltage comparators, comparing the differential voltage between the positive and negative pins and outputting a logic low or high impedance (logic high with pullup) based on the input differential polarity.

The open-drain output allows the user to configure the output's logic high voltage (VOH) and can be used to enable the comparator to be used in AND functionality. It is good design practice to ground all unused pins.

### Square-Wave Oscillator

The LM393 can be used to build a low cost square-wave oscillator as shown in Figure 1. The square-wave period is determined by the RC time constant of the capacitor (C1) and resistor (R4). The maximum frequency is limited by propagation delay of the device and the capacitance load at the output.

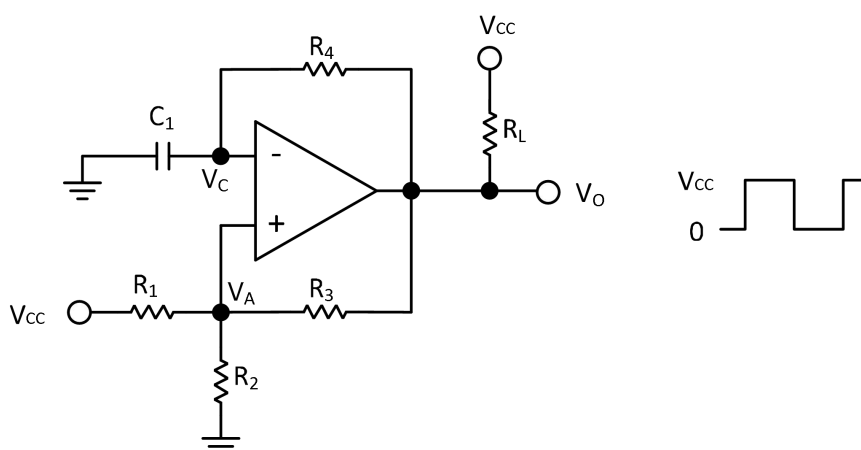

Figure 1. Square-Wave Oscillator

### Inverting Comparator with Hysteresis

When higher levels of hysteresis are required, positive feedback can be externally added. The inverting comparator with hysteresis requires a three-resistor network that is referenced to the comparator supply voltage (Vcc), as shown in Figure 1. When  $V_{IN}$  at the inverting input is less than  $V_T$ , the output voltage is high. The three network resistors can be represented as  $R1//R3$  in series with  $R2$ . Equation 1 defines the high to low trip voltage ( $V_{T1}$ ).

$$V_{T1} = \frac{R2 \cdot V_{cc}}{(R1//R3) + R2} \quad (1)$$

When  $V_{IN}$  is greater than  $V_A$ , the output voltage is low, very close to ground. In this case, the three network resistors can be presented as  $R2//R3$  in series with  $R1$ . Equation 2 define the low to high trip voltage ( $V_{T2}$ ).

$$V_{T2} = \frac{(R2//R3) \cdot V_{cc}}{(R2//R3)+R1} \quad (2)$$

The total hysteresis provided by the network is

$$\Delta V_T = V_{T1} - V_{T2} \quad (3)$$

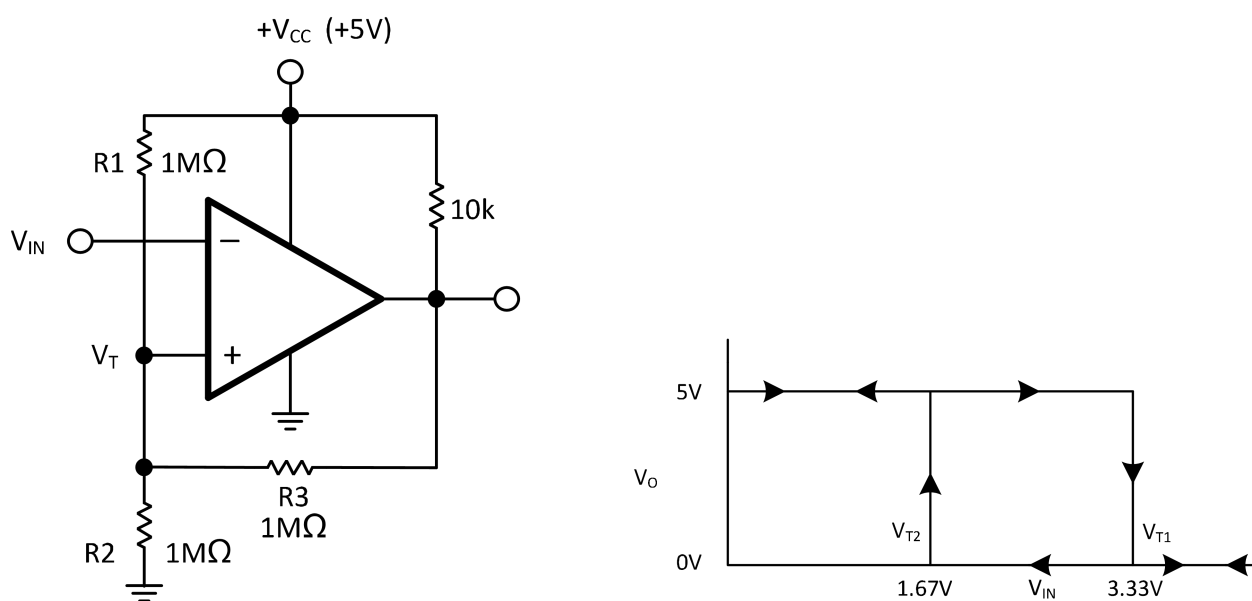

Figure 2. Inverting Configuration with Hysteresis

### Non-inverting Comparator with Hysteresis

A non-inverting comparator with hysteresis requires a two-resistor network, as shown in Figure 3, and a voltage reference ( $V_{REF}$ ) at the inverting input. When  $V_{IN}$  is low, the output is also low. For the output to switch from low to high,  $V_{IN}$  must rise to  $V_{IN1}$ . Equation 4 defines the low to high trip voltage ( $V_{IN1}$ ):

$$V_{IN1} = \frac{(R1+R2) \cdot V_{REF}}{R2} \quad (4)$$

When  $V_{IN}$  is high, the output is also high. For the comparator to switch back to a low state,  $V_{IN}$  must drop to  $V_{IN2}$ ,

$$V_{IN2} = \frac{(R1+R2) \cdot V_{REF} - R1 \cdot V_{CC}}{R2} \quad (5)$$

The hysteresis of this circuit is the difference between  $V_{IN1}$  and  $V_{IN2}$ , as shown in following,

$$\Delta V_{IN} = V_{CC} \times \frac{R1}{R2} \quad (6)$$

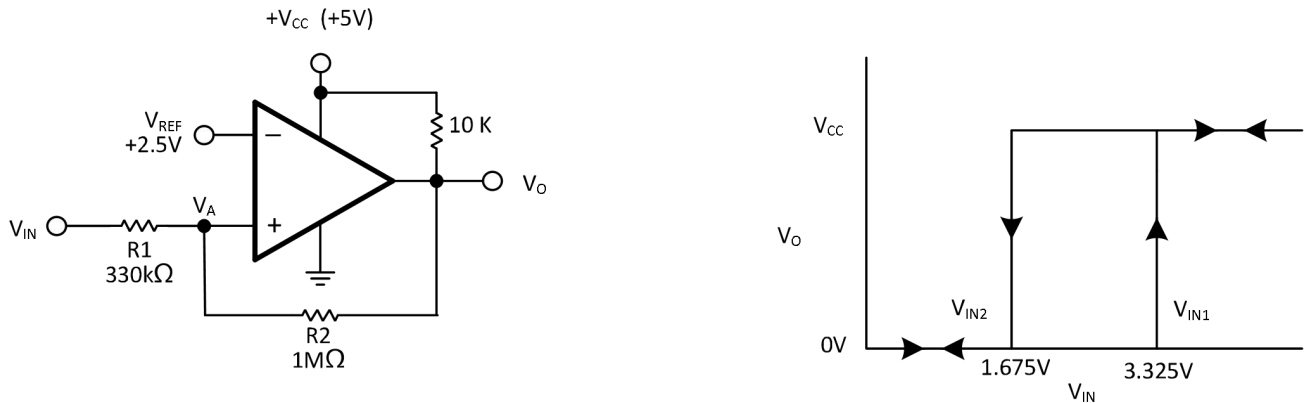

Figure 3. Non-inverting Configuration with Hysteresis

### Time Delay Generator

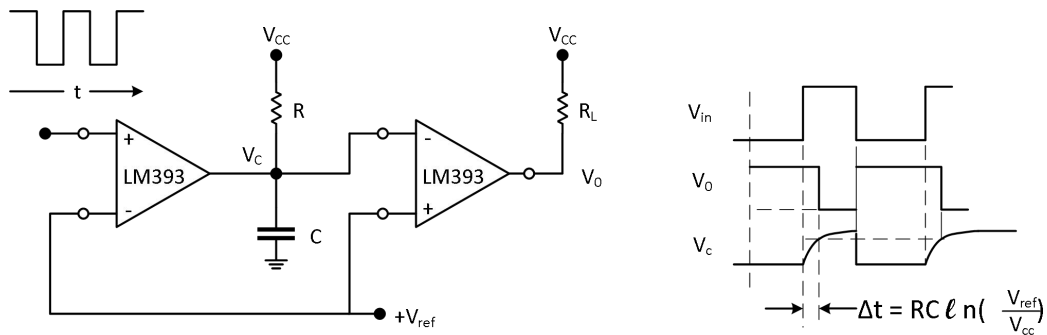

Figure 4. Time Delay Generator

### Power-Supply Bypassing and Layout

For single-supply operation, bypass the power supply  $V_{CC}$  with a  $0.1\mu\text{F}$  ceramic capacitor which should be placed close to the  $V_{CC}$  pin. For dual-supply operation, both the positive and negative supplies should be bypassed to ground with separate  $0.1\mu\text{F}$  ceramic capacitors.  $2.2\mu\text{F}$  tantalum capacitor can be added for better performance.

The length of the current path is directly proportional to the magnitude of parasitic inductances and thus the high frequency impedance of the path. High speed currents in an inductive ground return create an unwanted voltage noise. Broad ground plane areas will reduce the parasitic inductance. Thus a ground plane layer is important for high speed circuit design.

## 5. Package Information

### 5.1 SOP8 (Package Outline Dimensions)

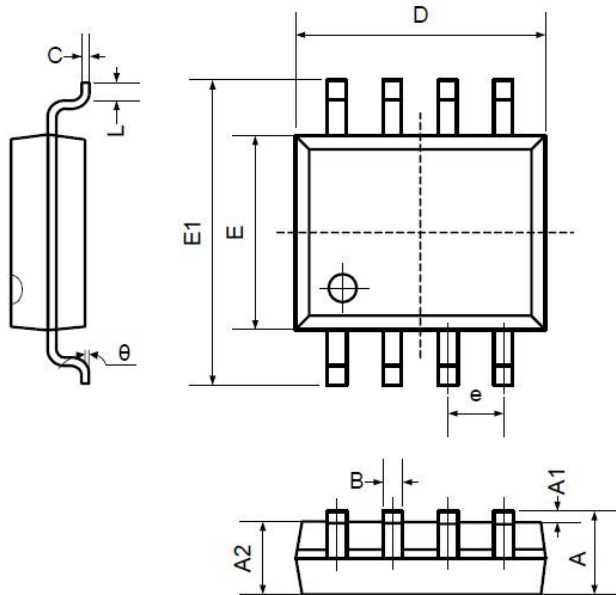

Symbol	Dimensions In Millimeters		Dimensions In Inches	
	Min	Max	Min	Max
A	1.350	1.750	0.053	0.069
A1	0.100	0.250	0.004	0.010
A2	1.350	1.550	0.053	0.061
B	0.330	0.510	0.013	0.020
C	0.190	0.250	0.007	0.010
D	4.780	5.000	0.188	0.197
E	3.800	4.000	0.150	0.157
E1	5.800	6.300	0.228	0.248
e	1.270TYP		0.050TYP	
L	0.400	1.270	0.016	0.050
θ	0°	8°	0°	8°

### 5.2 MSOP8 (Package Outline Dimensions)

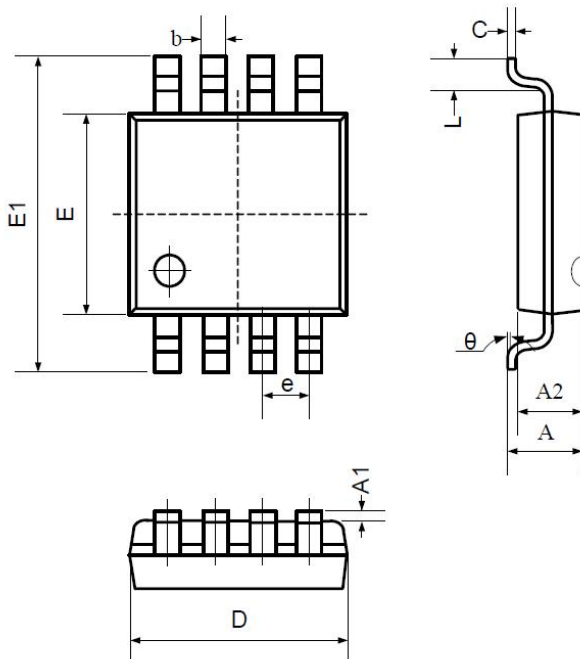

Symbol	Dimensions In Millimeters		Dimensions In Inches	
	Min	Max	Min	Max
A	0.800	1.200	0.031	0.047
A1	0.000	0.200	0.000	0.008
A2	0.760	0.970	0.030	0.038
b	0.30 TYP		0.012 TYP	
c	0.15 TYP		0.006 TYP	
D	2.900	3.100	0.114	0.122
e	0.65 TYP		0.026 TYP	
E	2.900	3.100	0.114	0.122
E1	4.700	5.100	0.185	0.201
L	0.410	0.650	0.016	0.026
θ	0°	6°	0°	6°



5.3 SOP14 (Package Outline Dimensions)

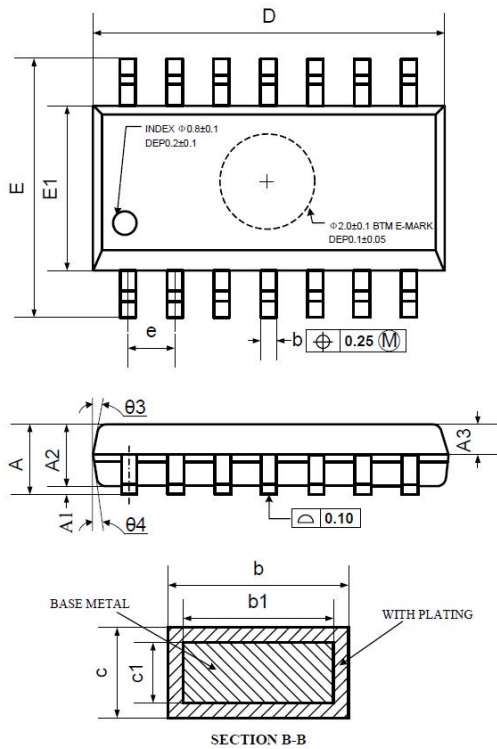

Symbol	Dimensions In Millimeters		
	MIN	NOM	MAX
A	1.35	1.60	1.75
A1	0.10	0.15	0.25
A2	1.25	1.45	1.65
A3	0.55	0.65	0.75
b	0.36		0.49
b1	0.35	0.40	0.45
c	0.16		0.25
c1	0.15	0.20	0.25
D	8.53	8.63	8.73
E	5.80	6.00	6.20
E1	3.80	3.90	4.00
e	1.27 BSC		
L	0.45	0.60	0.80
L1	1.04 REF		
L2	0.25 BSC		
R	0.07		
R1	0.07		
h	0.30	0.40	0.50
$\theta$	0°		8°
$\theta 1$	6°	8°	10°
$\theta 2$	6°	8°	10°
$\theta 3$	5°	7°	9°
$\theta 4$	5°	7°	9°

5.4 TSSOP14 (Package Outline Dimensions)

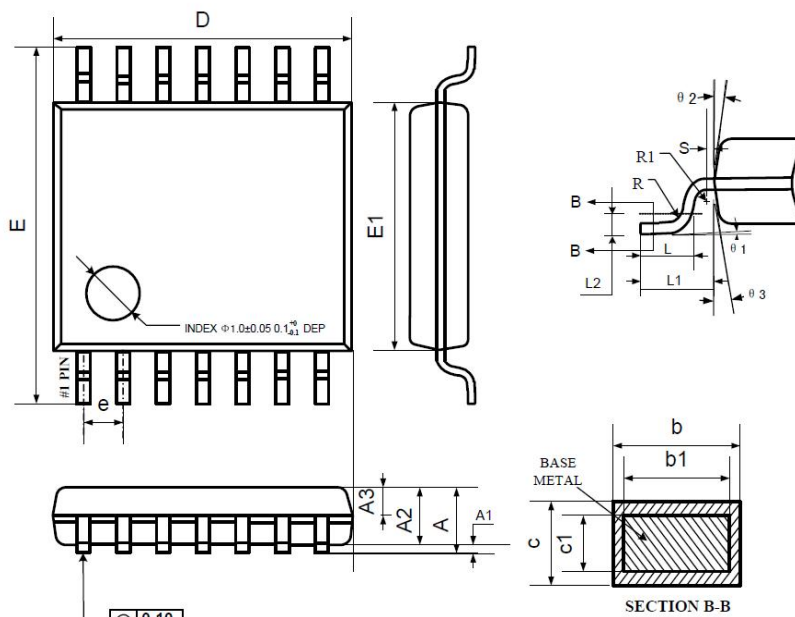

Symbol	Dimensions In Millimeters		
	MIN	NOM	MAX
A	—	—	1.20
A1	0.05	—	0.15
A2	0.90	1.00	1.05
A3	0.34	0.44	0.54
b	0.20	—	0.28
b1	0.20	0.22	0.24
c	0.10	—	0.19
c1	0.10	0.13	0.15
D	4.86	4.96	5.06
E	6.20	6.40	6.60
E1	4.30	4.40	4.50
e	0.65 BSC		
L	0.45	0.60	0.75
L1	1.00 REF		
L2	0.25 BSC		
R	0.09	—	—
R1	0.09	—	—
S	0.20	—	—
$\theta 1$	0°	—	8°
$\theta 2$	10°	12°	14°
$\theta 3$	10°	12°	14°

## X-ON Electronics

Largest Supplier of Electrical and Electronic Components

*Click to view similar products for [Analog Comparators](#) category:*

*Click to view products by [COSINE](#) manufacturer:*

Other Similar products are found below :

[SC2903VDR2G](#) [LM2901SNG](#) [LM339SNG](#) [55122](#) [5962-8757203IA](#) [NTE911](#) [LM339EDR2G](#) [NTE922](#) [UPC177GR-9LG-E2-A](#)  
[HT393VRMZ](#) [LM2903YD](#) [NCV2200SN1T1G](#) [LM2903A-SR](#) [LM339A-SR](#) [HT339ARQZ](#) [LM2901XP](#) [LM2903DR-JSM](#) [MS8923](#)  
[LM239AM/TR](#) [LM393LVQDGKRQ1](#) [LM393LVQPWRQ1](#) [LM2903BWDSGRQ1](#) [TLV3801DSGT](#) [LM331BXF](#) [AD790JRZ-REEL](#)  
[LM339A-TR](#) [LT6700HVHS6-1#TRPBF](#) [GS2903-SR](#) [LMV7219M5/TR](#) [LMV7239M5/TR](#) [LM293ADR-HXY](#) [LM293DR-HXY](#) [LM339N-](#)  
[HXY](#) [LM393P-HXY](#) [IL339DT](#) [LM2901XQ](#) [RS331XF-Q1](#) [MIC842NYMT-TR](#) [LM393FVM-TR](#) [LM393P](#) [TLV3602DGKR](#)  
[TLV3602QDGKRQ1](#) [TLV7032QDGKRQ1](#) [TLV3601QDBVRQ1](#) [LM2901BQPWRQ1](#) [TLV3603DCKR](#) [TLV3603DCKT](#)  
[AiP74HC85TA16.TB](#) [LMV331IDBVR\(MS\)](#) [LMV331TP-MS](#)