

Current-Mode PWM Controllers

Features

- 8-V to 30-V Operation
- Low Start-up Current: <1mA
- 5.1-V Reference Trimmed to 1%
- Current Mode Operation up to 500KHz
- Automatic Feed-forward Compensation
- Under-voltage Lockout With Hysteresis
- Latching PWM for Cycle-by-Cycle Current Limit
- Double-Pulse Suppression
- High Current Output Driver
- Optimized for off-line and DC-to-DC Converters
- Available Packaging:
SOP8/TSSOP8/DIP8

Applications

- Solar Inverters
- Switching Regulators of Any Polarity
- Motor Control
- Battery Chargers
- DC/DC Power Supplies

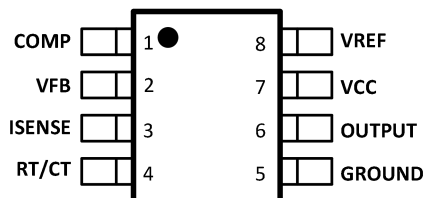

Pin Diagram

General Description

The COS UC384x series of controllers are peak current mode pulse width modulators. They are designed to offer improved performance and lowered external parts count when used in designing off-line or DC-to-DC switching power supplies. The internally implemented circuits include an under-voltage lockout (UVLO), featuring a start-up current of less than 1mA, and a precision reference trimmed for accuracy at the error amplifier input. Other internal circuits include logic to ensure latched operation, a pulse-width modulation (PWM) comparator that also provides current-limit control, and a totem-pole output stage that is designed to source or sink high-peak current. The output stage, suitable for driving N-channel MOSFETs, is low when it is in the off state.

The differences between COS UC384x family member are the under-voltage lockout thresholds and the maximum duty cycle ranges.

Model	UVLO Threshold	Max. Duty Cycle
COS UC3842	16V(Von) 10V(Voff)	100%
COS UC3843	8.4V(Von) 7.6V(Voff)	100%
COS UC3844	16V(Von) 10V(Voff)	50%
COS UC3845	8.4V(Von) 7.6V(Voff)	50%

Rev1.0

Copyright©2018 Cosine Nanoelectronics Inc. All rights reserved
The information provided here is believed to be accurate and reliable. Cosine Nanoelectronics assumes no reliability for inaccuracies and omissions. Specifications described and contained here are subjected to change without notice on the purpose of improving the design and performance. All of this information described herein should not be implied or granted for any third party.

1. Pin Configuration and Block Diagram

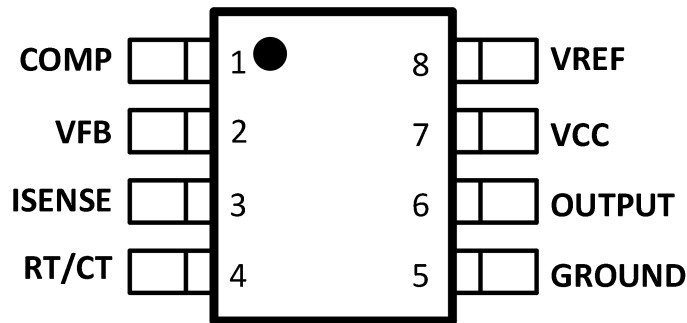

Figure 1. Pin Diagram

Table 1. Pin Description

Pin	Name	I/O	Description
1	COMP	O	Output of the error amplifier for compensation. Connect external compensation components to this pin to modify the error amplifier output. The error amplifier is internally current limited so the users can command zero duty cycle by externally forcing COMP to GROUND.
2	V _{FB}	I	Inverting input to the error amplifier. It is normally connected to the switching power supply output through a resistor divider.
3	I _{SENSE}	I	A voltage proportional to inductor current is connected to this input. The PWM uses his information to terminate the output switch conduction. A voltage ramp can be applied to this pin to run the device with a voltage-mode control configuration.
4	R _T /C _T	I/O	The oscillator frequency and maximum output duty cycle are programmed by connecting resistor R _T to V _{REF} and capacitor C _T to ground. Operation up to 1MHz is possible.
5	GROUND	P	Ground return pin. It functions as both power ground and analog ground.
6	OUTPUT	O	Output of the on-chip drive stage. It directly drives the gate of a power MOSFET. Peak current up to 1A are sourced and sunk by this pin. Output is actively held low when V _{CC} is below the turnon threshold.
7	V _{CC}	P	Power supply pin for the control IC. This pin should be bypassed with a 0.1-μF ceramic low ESL capacitor with minimal trace lengths. An additional bypass capacitor at least 10 times greater than the gate capacitance of the main switching MOSFET used in the design is also required on V _{CC} .
8	V _{REF}	O	5V reference. It provides charging current for capacitor C _T through resistor R _T . For stability, the reference should be bypassed with a 0.1-μF ceramic low ESL capacitor and minimal trace length to the ground plane.

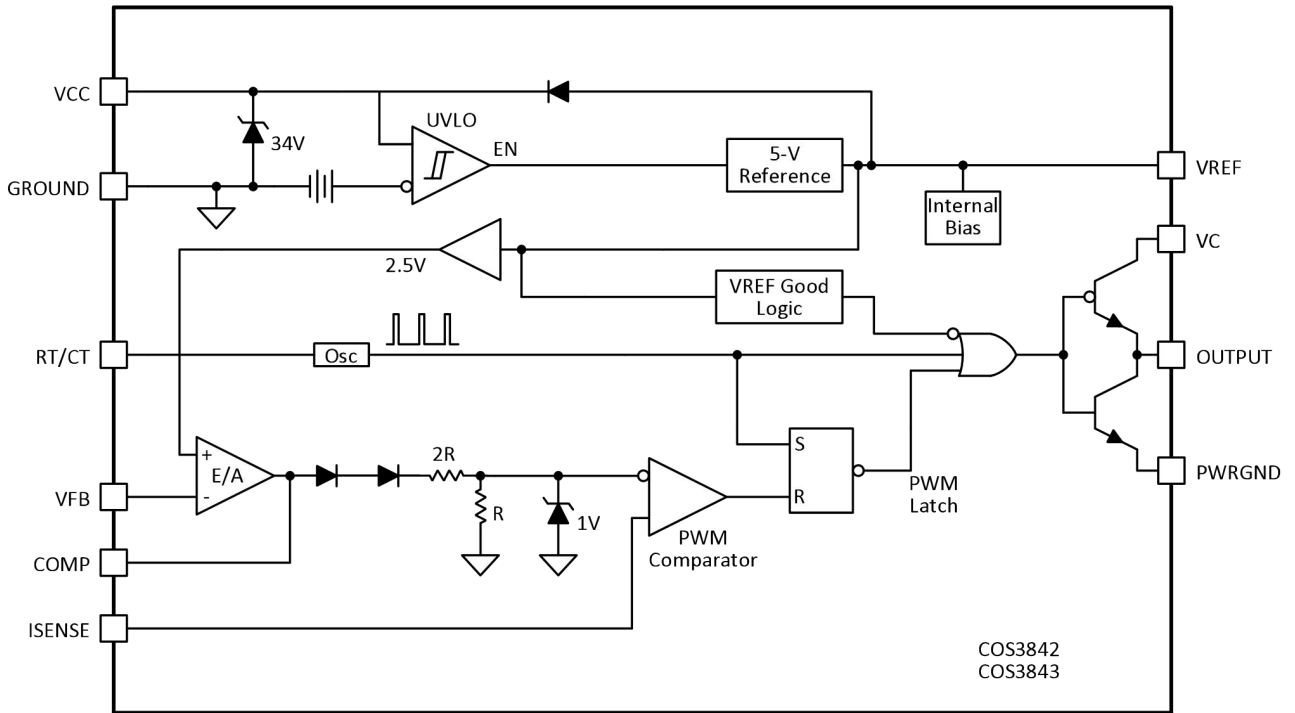

Figure 2. COS UC3842 and 3843 Block Diagram
(Note: with duty cycles approaching 100%)

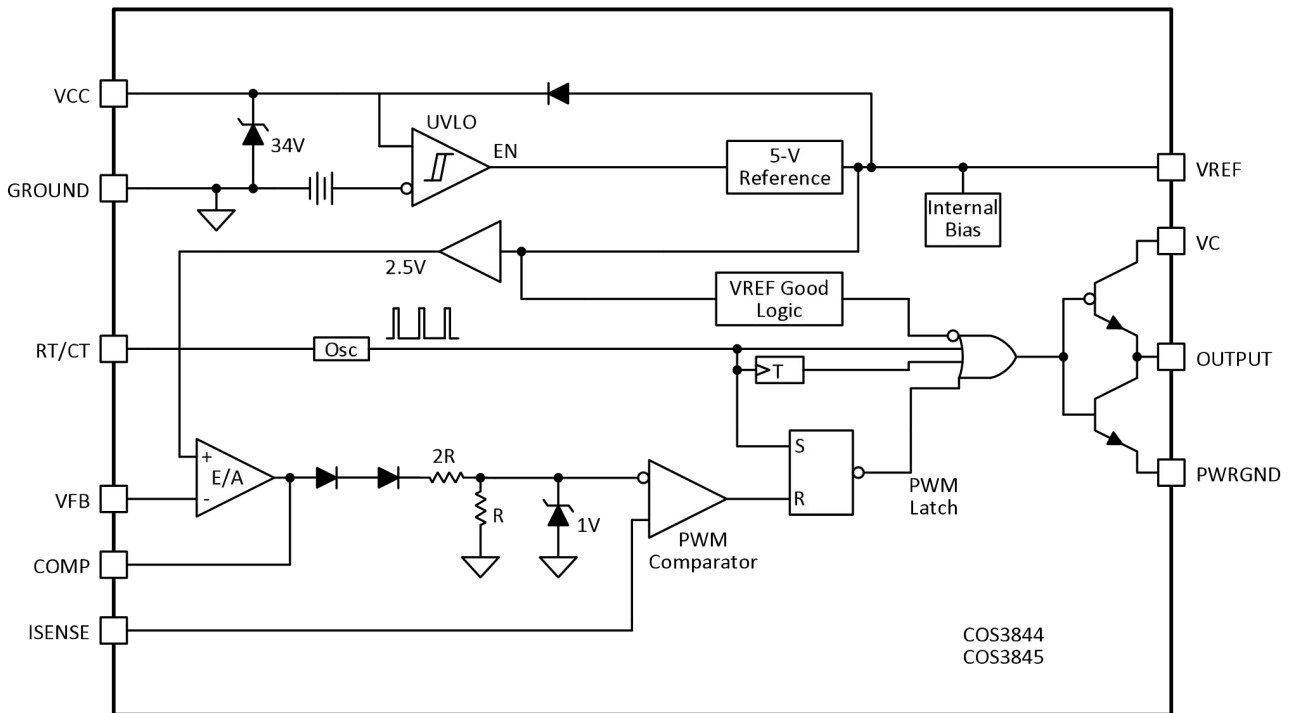

Figure 3. COS UC3844 and 3845 Block Diagram
(Note: with duty cycles approaching 50%)

2. Ordering Information

Model	Order Number	Package	Package Option	Marking Information
COS UC3842	COSUC3842BD	SOP-8	Tape and Reel, 3000	COS3842BD
	COSUC3842BN	DIP-8	Tube, 50	COS3842BN
COS UC3843	COSUC3843BD	SOP-8	Tape and Reel, 3000	COS3843BD
	COSUC3843BN	DIP-8	Tube, 50	COS3843BN
COS UC3844	COSUC3844BD	SOP-8	Tape and Reel, 3000	COS3844BD
	COSUC3844BN	DIP-8	Tube, 50	COS3844BN
COS UC3845	COSUC3845BD	SOP-8	Tape and Reel, 3000	COS3845BD
	COSUC3845BN	DIP-8	Tube, 50	COS3845BN

3. Product Specification

3.1 Absolute Maximum Ratings ⁽¹⁾

Parameter	Sym.	Min	Max	Unit
Supply Voltage	V _{CC}		30	V
Analog Inputs	V _{FB} , I _{SENSE}	-0.3	6	V
Output Current, Source or Sink	I _o		±1	A
Error Amplifier Output Sink Current	I _{COMP}		10	mA
Operating Junction Temperature	T _J	-40	+125	°C
Storage Temperature	T _s	-55	+150	°C
Lead Temperature (soldering 10s)	T _L		+300	°C

(1) Stresses exceeding the absolute maximum ratings may damage the device. The device may not function or be operable above the recommended operating conditions and stressing the parts to these levels is not recommended. In addition, extended exposure to stresses above the recommended operating conditions may affect device reliability. The absolute maximum ratings are stress ratings only.

3.2 Thermal Data

Parameter	Rating	Unit
Package Thermal Resistance, R _{θJA} (Junction-to-ambient)	150 (SOP8) 90 (DIP8)	°C/W

3.3 Recommended Operating Conditions

Parameter	Min.	Typ.	Max.	Unit
V _{CC} Supply Voltage	-	-	30	V
V _{FB} Input Voltage	-	-	2.5	V
I _{SENSE} Input Voltage	-	-	1	V
Sink/Source Load Current (average)		-	200	mA
Reference Load Current	0	-	20	mA
Oscillator Frequency Range	-	100	500	kHz
Operating Junction Temperature	-40	-	+125	°C

3.4 Electrical Characteristics

(Typical values are tested at V_{CC}=20V, T_A=25 °C, unless otherwise specified.)

Parameter	Sym.	Conditions	Min.	Typ.	Max.	Unit
POWER SUPPLY						
Supply Voltage	V _{CC}		7.6	-	30	V
Operating Supply Current	I _S	V _{FB} = V _{ISENSE} = 0 V	-	12	17	mA
Start-up Current				0.1	0.3	mA
REFERENCE						
Output Voltage	V _{REF}		4.95	5.0	5.05	V
Line Regulation	ΔV _{REF}	V _{IN} = 8 V to 30 V	-	10	20	mV
Load Regulation	ΔV _{REF}	I _L = 0 to 20 mA	-	20	50	mV
Temp. Stability	ΔV _{REF}	Over operating range		20	50	mV
Total Output Variation	V _{REF}	Line, Load, and Temperature	4.9	-	5.1	V
Short Circuit Output Current	I _{SC}	V _{REF} =0	30	100	180	mA
OSCILLATOR						
Frequency	f _{OSC}	R _T = 10 kΩ, C _T = 3.3 μF	47	52	57	kHz
Voltage Stability	Δf/ΔV _{IN}	V _{IN} = 12 V to 25 V	-	0.2	1	%
Temperature Stability	Δf/ΔT	V _{IN} = 12 V to 25 V	-	5	-	%

Clock Amplitude	$V_{RT/CT}$		-	1.6	-	V
ERROR AMPLIFIER						
Input Voltage	V_{FB}		2.42	2.5	2.58	V
Input Bias Current	I_B		-	0.1	2	μA
Open Loop Voltage Gain	G_{VOL}	$2 \leq V_{COMP} \leq 4 V$	65	90	-	dB
Gain-Bandwidth Product	GBP	$A_v = 0 \text{ dB}$	0.7	1	-	MHz
Power Supply Rejection Ratio	PSRR ₁	$V_{IN} = 12V \text{ to } 25V$	60	70	-	dB
COMP Sink Current	I_{SK}	$V_{FB} = 2.7 V, V_{COMP} = 1.1V$	2	12	-	mA
COMP Source Current	I_{SRC}	$V_{FB} = 2.3 V, V_{COMP} = 5V$	-0.5	-1	-	mA
Low-level Output Voltage	V_{OL}	$V_{FB} = 2.7 V;$ $R_L = 15\text{-k}\Omega \text{ COMP to } V_{REF}$		0.8	1.1	V
High-level Output Voltage	V_{OH}	$V_{FB} = 2.3 V;$ $R_L = 15\text{-k}\Omega \text{ COMP to Ground}$	5	6.2		V
PWM COMPARATOR						
Gain	G_{COMP}	$G = \Delta V_{COMP} / \Delta V_{ISENSE},$ $0 V \leq V_{ISENSE} \leq 0.8 V$	2.85	3	3.15	V/V
Maximum Input Signal	V_{ISENSE}		0.9	1	1.1	V
Input Bias Current	I_{ISENSE}		-	-2	-10	μA
Power Supply Rejection Ratio	PSRR ₂	$V_{CC} = 12V \text{ to } 25V$	-	70	-	dB
Delay to Output	t_{DLY}	V_{ISENSE} stepped from 0 to 2 V		150	300	ns
OUTPUT DRIVER						
Low-level Output Voltage	$V_{OL I}$	$I_{SINK} = 20 \text{ mA}$	-	0.2	0.4	V
	$V_{OL II}$	$I_{SINK} = 200 \text{ mA}$	-	1.6	2.2	V
High-level Output Voltage	$V_{OH I}$	$I_{SOURCE} = 20 \text{ mA}$	18	19	-	V
	$V_{OH II}$	$I_{SOURCE} = 200 \text{ mA}$	17	18	-	V
Rise Time	t_R	$C_L = 1 \text{ nF}$	-	50	150	ns
Fall Time	t_F	$C_L = 1 \text{ nF}$	-	50	150	ns

UNDER-VOLTAGE LOCKOUT (UVLO)						
UVLO Enable Threshold	UVL _{ON}	COS3842/3844	14.5	16	17.5	V
		COS3843/3845	7.8	8.4	9.0	V
UVLO Off Threshold	UVL _{OFF}	COS3842/3844	8.5	10	11.5	V
		COS3843/3845	7.0	7.6	8.2	V
PWM DUTY CYCLE						
Maximum Duty Cycle	D _{MAX}	COS3842/3843	94	96	100	%
		COS3844/3845	47	48	50	%
Minimum Duty Cycle	D _{MIN}				0	%

4. Application Information

4.0 Overview

The COS UC384x series of pulse width modulator (PWM) integrated circuits provide the features necessary to implement AC-DC or DC-to-DC fixed-frequency current mode control schemes with a minimum number of external components. Protection circuitry includes undervoltage lockout (UVLO) and current limiting. Internally implemented circuits include a start-up current of less than 1mA, a precision reference trimmed for accuracy at the error amplifier input, logic to ensure latched operation, a pulse-width modulation (PWM) comparator that also provides current-limit control, and a totem-pole output stage designed to source and sink high-peak current. The output stage, suitable for driving N-channel MOSFETs, is low when it is in the off-state.

The differences between members of COS UC384x series are the UVLO thresholds and maximum duty-cycle as shown in Table 2.

Table 2. Device Information

Model	UVLO Threshold	Max. Duty Cycle
COS UC3842	16V(V _{on}) 10V(V _{off})	100%
COS UC3843	8.4V(V _{on}) 7.6V(V _{off})	100%
COS UC3844	16V(V _{on}) 10V(V _{off})	50%
COS UC3845	8.4V(V _{on}) 7.6V(V _{off})	50%

Typical UVLO thresholds of 16V(ON) and 10V(OFF) on the COS UC3842 and 3844 devices make them ideally suited to off-line AC-DC applications. The corresponding typical thresholds for the COS UC3843 and 3845 devices are 8.4V(ON) and 7.6V(OFF), making them ideal for use with regulated input voltages used in DC-DC applications. The COS UC3842 and 3843 devices operate at duty cycles approaching 100%. The COS UC3844 and 3845 have a duty-cycle range of 0% to 50% by the addition of an internal toggle flip-flop, which blanks the output off every other clock cycle.

The COS UC384x uses an external resistor to set the charging current for the external capacitor, which determines the oscillator frequency as following equation:

$$f_{OSC} = 1.72 / (R_{RT} \times C_{CT}) \tag{1}$$

The recommended range of timing resistor values is between 5 kΩ and 100 kΩ; the recommended range of timing capacitor values is between 1 nF and 100 nF.

4.1 Open-Loop Test Fixture

An open-loop laboratory test fixture (Figure 4) is used to demonstrate the setup and use of the COS UC3842 devices and their internal circuitry. The transistor and 5-kΩ potentiometer sample the oscillator waveform and apply an adjustable ramp to the I_{SENSE} terminals. High peak currents associated with capacitive loads necessitate careful grounding techniques. Timing and bypass capacitors should be connected close to pin 5 in a single point ground.

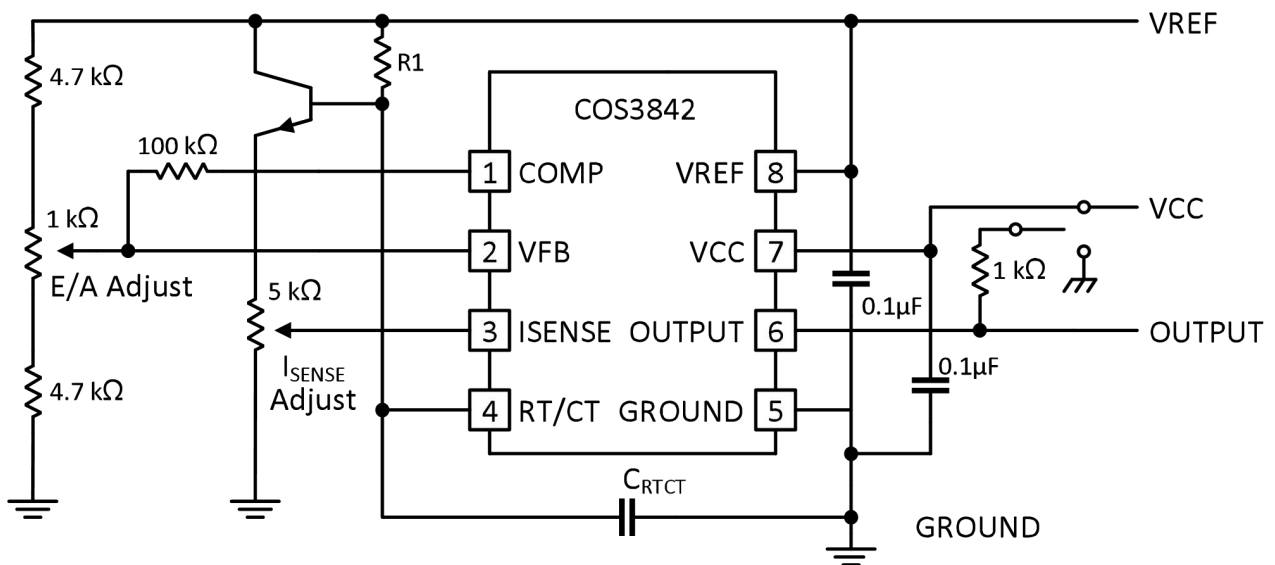

Figure 4. Open-Loop Laboratory Test Fixture

4.2 Typical Application

A typical application for the COS UC3842 in an off-line flyback converter is shown in Figure 5. It is capable of providing 48W at 12V output voltage from a universal AC input. The design uses peak primary current control in a continuous current mode PWM converter.

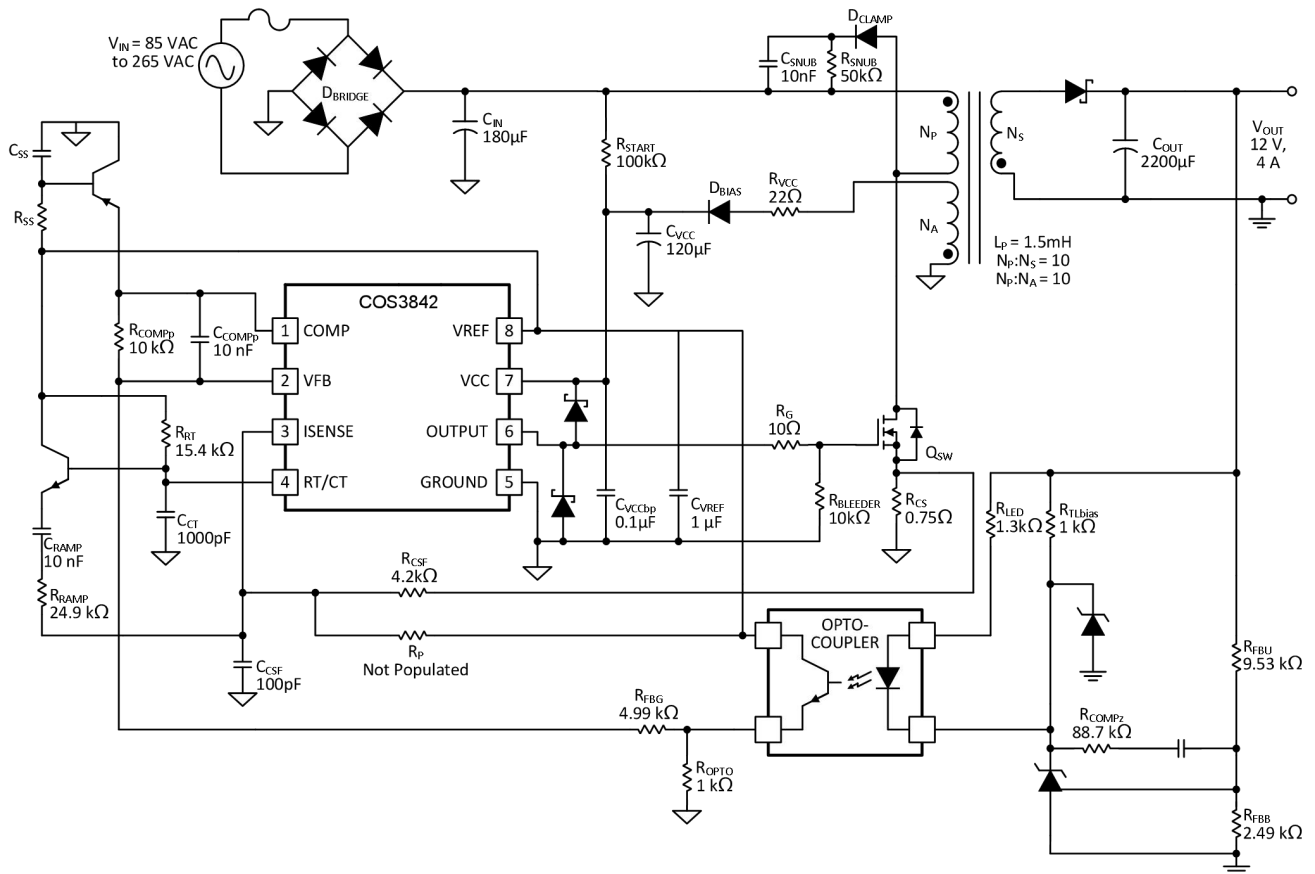
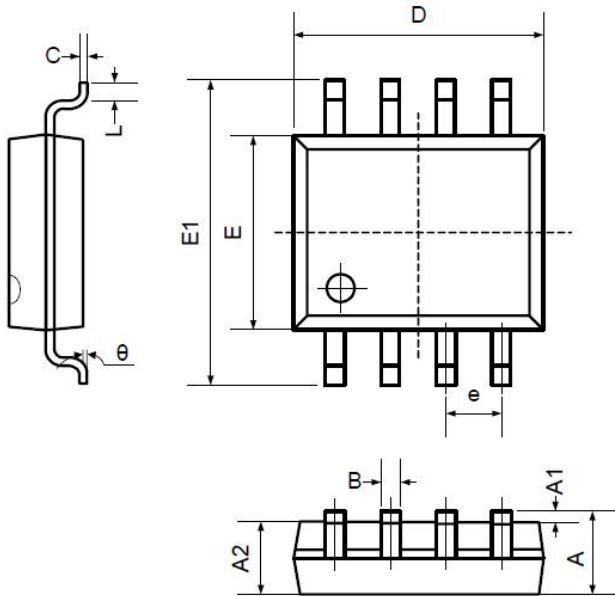

Figure 5. An Off-Line Flyback Converter Scheme

5. Package Information

5.1 SOP8 (Package Outline Dimensions)



Symbol	Dimensions In Millimeters		Dimensions In Inches	
	Min	Max	Min	Max
A	1.350	1.750	0.053	0.069
A1	0.100	0.250	0.004	0.010
A2	1.350	1.550	0.053	0.061
B	0.330	0.510	0.013	0.020
C	0.190	0.250	0.007	0.010
D	4.780	5.000	0.188	0.197
E	3.800	4.000	0.150	0.157
E1	5.800	6.300	0.228	0.248
e	1.270TYP		0.050TYP	
L	0.400	1.270	0.016	0.050
θ	0°	8°	0°	8°

5.2 DIP8 (Package Outline Dimensions)

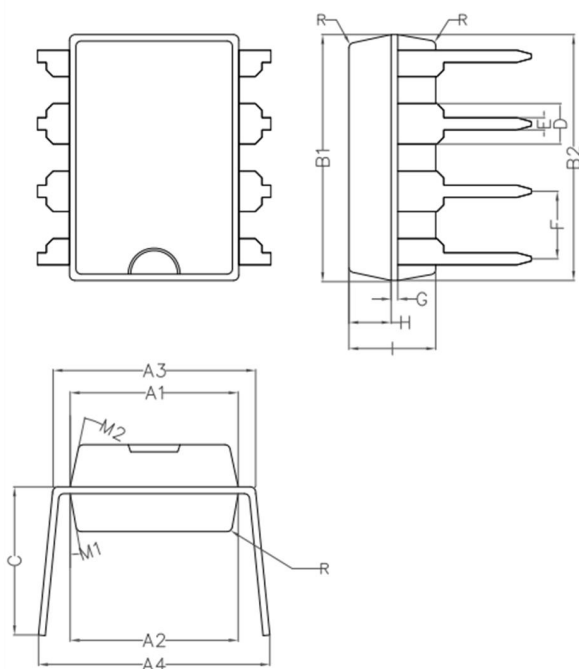

Symbol	Min	Non	Max
A1	6.28	6.33	6.38
A2	6.33	6.38	6.43
A3	7.52	7.62	7.72
A4	7.80	8.40	9.00
B1	9.15	9.20	9.25
B2	9.20	9.25	9.30
C		5.57	
D		1.52	
E	0.43	0.45	0.47
F		2.54	
G		0.25	
H	1.54	1.59	1.64
I	3.22	3.27	3.32
R		0.20	
M1	9°	10°	11°
M2	11°	12°	13°

X-ON Electronics

Largest Supplier of Electrical and Electronic Components

Click to view similar products for [Switching Voltage Regulators](#) category:

Click to view products by [COSINE](#) manufacturer:

Other Similar products are found below :

[FAN53610AUC33X](#) [FAN53611AUC123X](#) [EN6310QA](#) [160215](#) [R3](#) [KE177614](#) [FAN53611AUC12X](#) [MAX809TTR](#) [NCV891234MW50R2G](#)
[AST1S31PUR](#) [NCP81203PMNTXG](#) [NCP81208MNTXG](#) [PCA9412AUKZ](#) [NCP81109GMNTXG](#) [NCP3235MNTXG](#) [NCP81109JMNTXG](#)
[NCP81241MNTXG](#) [NTE7223](#) [NTE7222](#) [NTE7224](#) [L6986FTR](#) [MPQ4481GU-AEC1-P](#) [MP8756GD-P](#) [MPQ2171GJ-P](#) [MPQ2171GJ-AEC1-P](#)
[N JW4153U2-A-TE2](#) [MP2171GJ-P](#) [MP28160GC-Z](#) [MPM3509GQVE-AEC1-P](#) [XDPE132G5CG000XUMA1](#) [LM60440AQRPKRQ1](#)
[MP5461GC-P](#) [IW673-20](#) [NCV896530MWATXG](#) [MPQ4409GQBE-AEC1-P](#) [S-19903DA-A8T1U7](#) [S-19903CA-A6T8U7](#) [S-19903CA-](#)
[S8T1U7](#) [S-19902BA-A6T8U7](#) [S-19902CA-A6T8U7](#) [S-19902AA-A6T8U7](#) [S-19903AA-A6T8U7](#) [S-19902AA-S8T1U7](#) [S-19902BA-A8T1U7](#)
[AU8310](#) [LMR23615QDRRRQ1](#) [LMR33630APAQRNXRQ1](#) [LMR33630APCQRNXRQ1](#) [LMR36503R5RPER](#) [LMR36503RFRPER](#)