



1 Description

The RedRock® RR122-3C72-511/512 and RR122-3C73-511/512 digital magnetic sensors are ideal for use in medical, industrial, automotive, and consumer applications. They are based on patented Tunneling Magnetoresistance (TMR) technology with seamless CMOS integration.

The RR122-3C72-511/512 and RR122-3C73-511/512 feature an operate sensitivity of 10 G (1.0 mT) with a bipolar magnetic field response. They offer a wide supply voltage range from 1.7 V up to 5.5 V, ideal for applications ranging from small battery-powered electronics to industrial machinery. They have a low average current drain (11 µA) for an active magnetic sensor, operating at 2500 Hz and high operating temperature range from -40°C up to 125°C.

2 Features

- ▶ Operate sensitivity of 10 G
- ▶ Lowest Average Current < 11 µA
- ▶ Wide Supply Voltage Ranges Available Down to 1.7V, Up to 5.5V
- ▶ Bipolar Latching Push-Pull Response
- ▶ Operating Frequency of 2500 Hz
- ▶ Temperature Rated up to 125°C
- ▶ RoHS & REACH Compliant

3 Applications

- ▶ Proximity Detection
- ▶ Linear Position Sensing
- ▶ Rotary Sensing
- ▶ Utility Meters
- ▶ Motor Controllers
- ▶ Consumer Electronics

Device Information

| Part Series | Package | Body Size (mm) | Temp Rating °C |
|-----------------------|----------|--------------------|----------------|
| RR122-3C72-511 | SOT-23-3 | 2.9 x 1.6 x 1.2 | -40 to +85 |
| RR122-3C72-512 | LGA-4 | 1.45 x 1.45 x 0.44 | -40 to +85 |
| RR122-3C73-511 | SOT-23-3 | 2.9 x 1.6 x 1.2 | -40 to +125 |
| RR122-3C73-512 | LGA-4 | 1.45 x 1.45 x 0.44 | -40 to +125 |

Device Packages



Functional Block Diagram for Digital Push-Pull Output

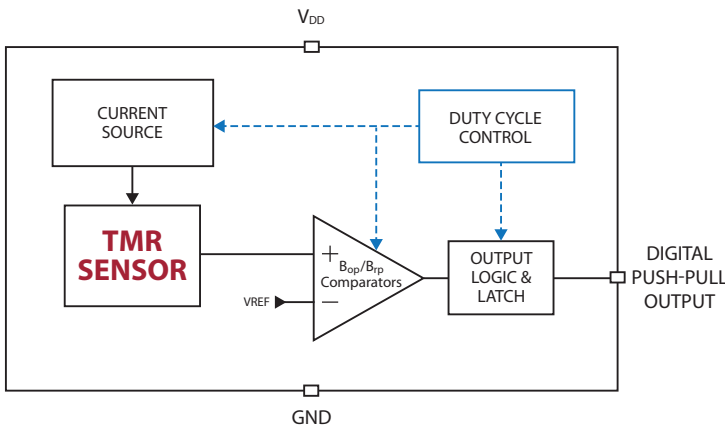

Device Nomenclature

Ordering Information

RR122-X X X X-YYY

| Series | Package |
|-----------------------------------|---------------------------|
| Magnetic Polarity Response | 1: SOT-23-3 |
| 1 = Omnipolar | 2: LGA-4 |
| 2 = Unipolar | 5: SOT-23-5 |
| 3 = Bipolar/Latch | Output Response |
| Magnetic Sensitivity (G) | 1: Active Low |
| A: Op 9, Rel 5 | Supply Voltage (V) |
| B: Op 30, Rel 20 | 5: 1.7 - 5.5 |
| C: Op 10, Rel -10 | Temp Rating (°C) |
| Clock Frequency (Hz) | 2: -40 - +85 |
| 1: 2 | 3: -40 - +125 |
| 5: 250 | |
| 9: 10000 | |
| 2: 10 | |
| 6: 500 | |
| U: 100+Turbo (10000) | |
| 3: 20 | |
| 7: 2500 | |

4 Specifications

4.1 Absolute Environmental Ratings^{1,2}

| Parameters | Units | Min | Typ | Max |
|---|-------|-------|-----|------|
| Operating Temperature (T _{OP}) (RR122-3C72-511/512) | °C | -40 | | +85 |
| Operating Temperature (T _{OP}) (RR122-3C73-511/512) | °C | -40 | | +125 |
| Storage Temperature (T _{STG}) | °C | -65 | | +150 |
| Junction Temperature (T _J) | °C | | | +150 |
| Soldering Temperature (3 cycles, 1 min.) (T _{SOL}) | °C | | | +260 |
| ESD Level Human Body Model per JESD22-A114 | V | ±4000 | | |
| Junction-to-Ambient Thermal Resistance (SOT-23-3) | °C/W | | 215 | |
| Junction-to-Ambient Thermal Resistance (LGA-4) | °C/W | | 165 | |
| Maximum Magnetic Field Exposure (B _{MAX}) | G | | | 600 |

4.2 Absolute Electrical Ratings^{1,2}

| Parameters | Units | Min | Typ | Max |
|---|-------|------|-----|-----------------|
| Supply Voltage (V _{DD}) | V | -0.3 | | 6.0 |
| Push-pull Output (Active Low)(V _{OUT_PP}) | V | -0.3 | | V _{DD} |
| Input and Output Current (I _{IN} /I _{OUT}) | mA | | | ±20 |

Notes:

- Exceeding Absolute Ratings may cause permanent damage to the device. Exposure at the maximum rated conditions for extended periods of time may also affect device reliability.
- Unless otherwise specified, all characteristics are measured at 25°C.



ESD Note: This product uses semiconductors that can be damaged by electrostatic discharge (ESD). When handling, proper ESD precautions should be taken to avoid performance degradation or loss of functionality. Damage due to inappropriate handling is not covered under warranty.

4 Specifications (cont.)

4.3 Operating Electrical Characteristics for RR122-3C72-511/512¹ and RR122-3C73-511/512¹

| Parameters | Units | Min | Typ | Max |
|--|---------|--------------|------|--------------|
| Supply Voltage (V_{DD}) | V | 1.7 | 3.0 | 5.5 |
| Power-On Time (t_{ON})($V_{DD} > 90\%$) | μ s | | 50 | 75 |
| Peak Power-On Current | mA | | | 1.4 |
| Output Voltage (High) (V_{OUTH}) | V | 90% V_{DD} | | |
| Output Voltage (Low) (V_{OUTL}) | V | | | 10% V_{DD} |
| Under Voltage Lockout Threshold Rising V_{DD} ($V_{UVLO-RISE}$) | V | | 1.60 | 1.64 |
| Under Voltage Lockout Threshold Falling V_{DD} ($V_{UVLO-FALL}$) | V | 1.44 | 1.53 | |
| Under Voltage Lockout Hysteresis ($V_{UV-HYST}$) | mV | | 50 | |
| Average Supply Current @ $V_{DD}=1.7$ V, $f_{SW}=2500$ Hz (I_{DD-AVG}) | μ A | | 9 | |
| Average Supply Current @ $V_{DD}=3.0$ V, $f_{SW}=2500$ Hz (I_{DD-AVG}) | μ A | | 11 | |

Notes:

1. Unless otherwise specified, $V_{DD} = 1.7$ V to 5.5 V, $T_A = -40^\circ\text{C}$ to $+85^\circ\text{C}$ (3C72), -40°C to $+125^\circ\text{C}$ (3C73). Typical values are $V_{DD} = 3.0$ V and $T_A = +25^\circ\text{C}$.



ESD Note: This product uses semiconductors that can be damaged by electrostatic discharge (ESD). When handling, proper ESD precautions should be taken to avoid performance degradation or loss of functionality. Damage due to inappropriate handling is not covered under warranty.

4.4 Operating Characteristics for RR122-3C72-511/512¹ and RR122-3C73-511/512¹

| Parameters | Units | Min | Typ | Max |
|--|---------|------|------|------|
| Switching Frequency (f_{SW}) | Hz | 1500 | 2500 | 3500 |
| Active Mode Time (t_{ACT}) | μ s | | 2.6 | |
| Idle Mode Time @ $f_{SW}=2500$ Hz (t_{IDLE}) | μ s | 285 | 400 | 667 |
| Operate Point (B_{OPN}) | G | 7 | 10 | 13 |
| Release Point (B_{RPS}) | G | -13 | -10 | -7 |

Notes:

1. Unless otherwise specified, $V_{DD} = 1.7$ V to 5.5 V, $T_A = -40^\circ\text{C}$ to $+85^\circ\text{C}$ (3C72), -40°C to $+125^\circ\text{C}$ (3C73). Typical values are $V_{DD} = 3.0$ V and $T_A = +25^\circ\text{C}$.

5 Output Response vs. Magnetic Flux

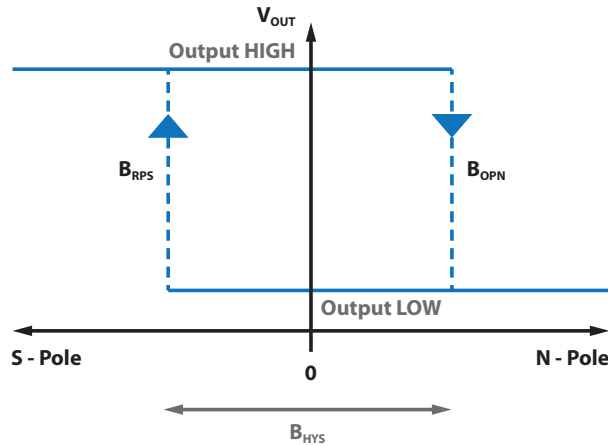

6 Application Information

RR122 Push-Pull Output Application Circuit

The output voltage on the RR122 is active low, meaning that while a sufficiently strong magnetic field is present, the output voltage is low. The output voltage can be connected to a digital I/O pin on a microcontroller. A decoupling capacitor with a minimum value of 1.0 μ F placed within 10 mm of the sensor is required.

6.1 Application Circuit (SOT-23-3)

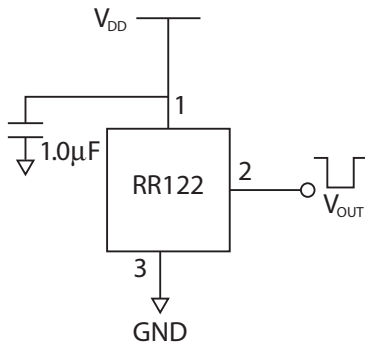

6.2 Application Circuit (LGA-4)

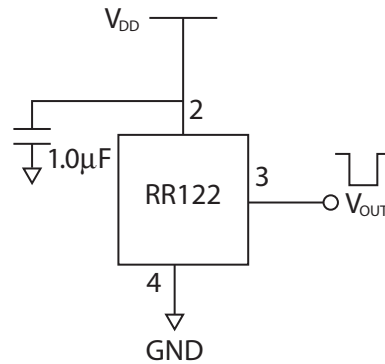

7 Axis of Sensitivity

7.1 SOT-23-3

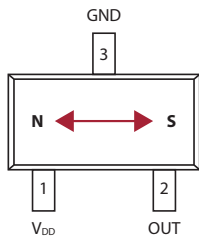

7.2 LGA-4

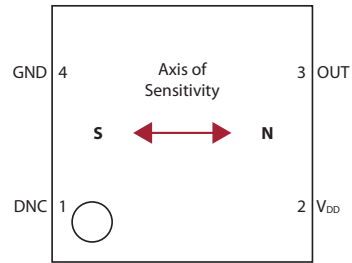

8 Dimensions SOT-23-3 Package *Millimeters (Inches)*

8.1 SOT-23-3 Package

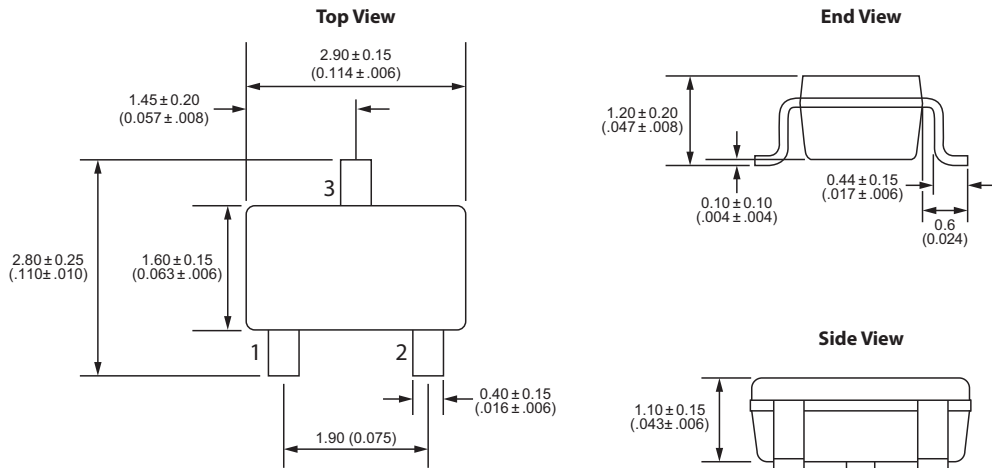

8.2 LGA-4 Package

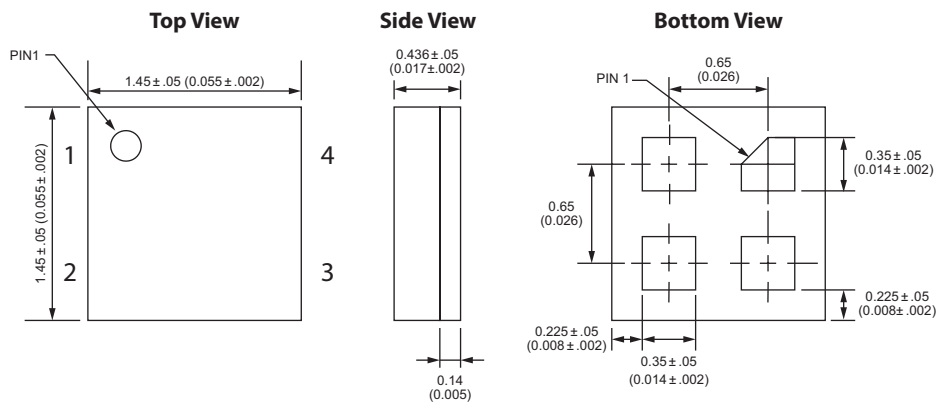

9 TMR Sensor Location

9.1 SOT-23-3 Package

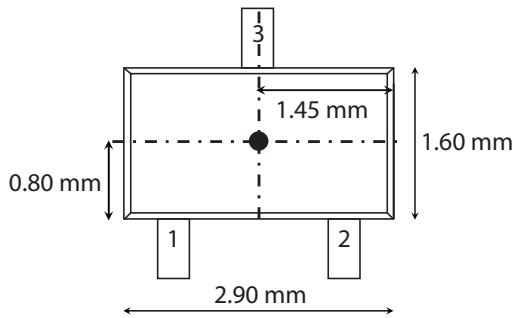

9.2 LGA-4 Package

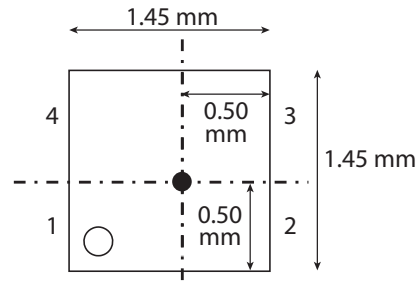

9.3 SOT Package - Side View

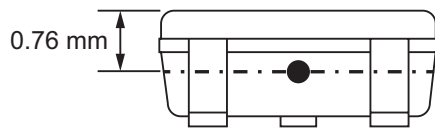

9.4 LGA Package - Side View

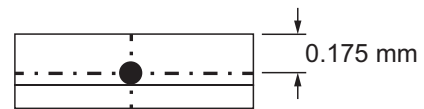

10 Output Behavior vs. Magnetic Field Diagrams

Output Behavior vs. Magnetic Field - Bipolar

| Characteristics | Conditions | Output |
|-----------------|---------------|------------|
| South Pole | $B < B_{RPS}$ | High (OFF) |
| North Pole | $B > B_{OPN}$ | Low (ON) |

11 TMR Sensor & Switch Packaging

11.1 SOT-23-3 Tape & Reel Packaging

Standard packaging is Tape & Reel containing 3,000 pieces. MSL Rating is 1.

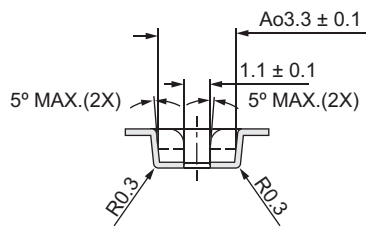
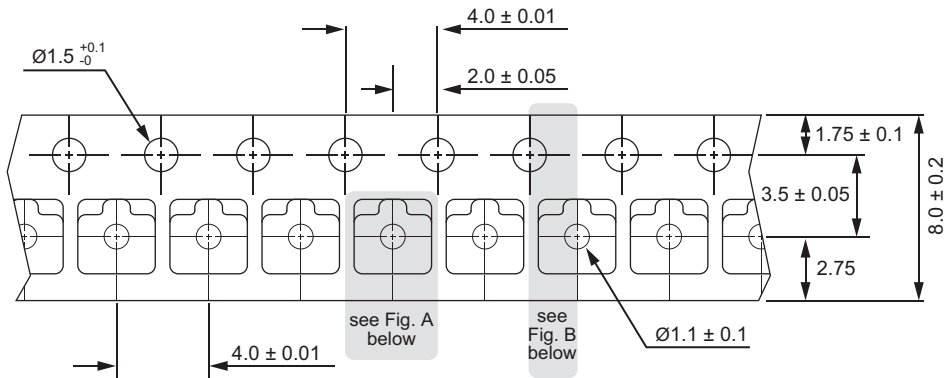

Fig. A

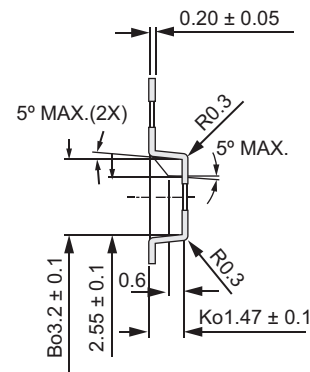
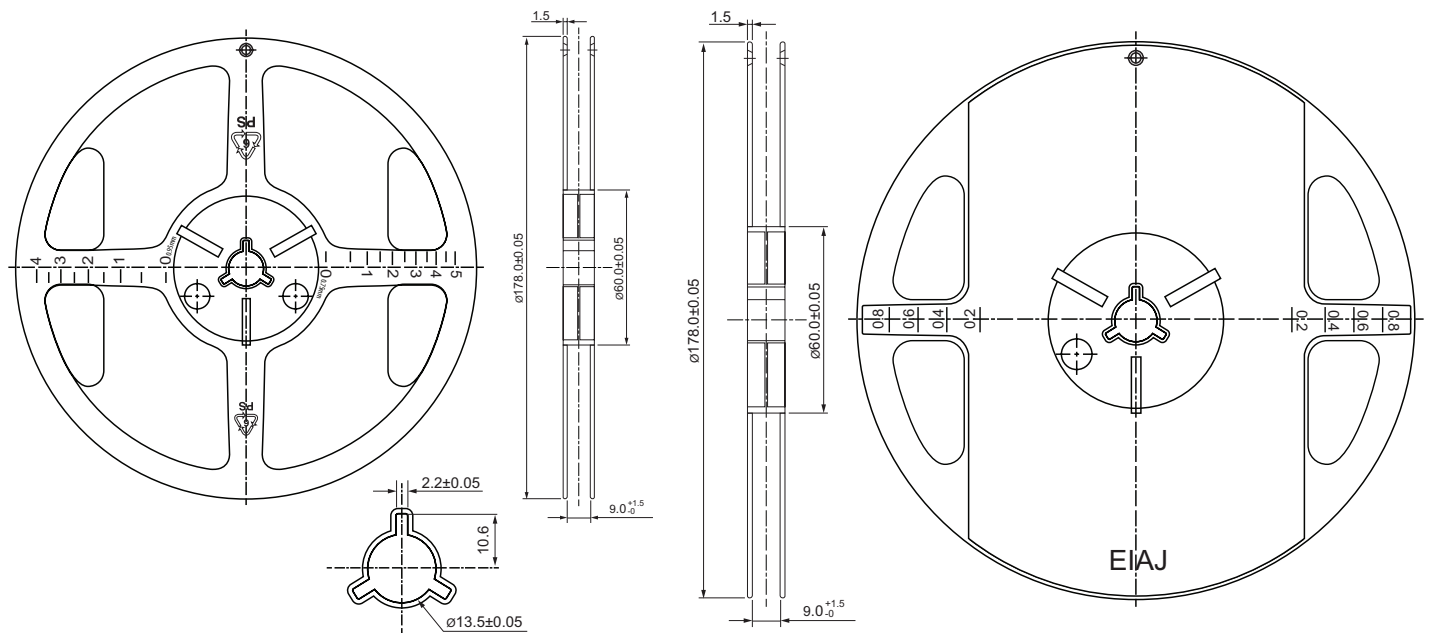

Fig. B



11 TMR Sensor & Switch Packaging

11.3 RedRock TMR Packaging

Box Dimensions – 14x10x6 inches

- Fits 1 to 3 reels = 3000 to 9000 pcs
- Weight for 3000 pcs = 0.90 kilos
- Weight for 9000 pcs = 1.00 kilos

Box Dimensions – 18x14x12 inches

- Fits 4 to 24 reels = 12000 to 72000 pcs
- Weight for 12000 pcs = 1.50 kilos
- Weight for 72000 pcs = 4.90 kilos

12 Suggested Pb-Free Reflow Profile

Notes:

1. Fully compatible with standard no-lead solder profile, 260 °C for 30 seconds max (3 cycles max).
2. Profile shown as example. Users are advised to develop their own board-level profile.
3. Suggested Pb-free reflow profile derived from IPC/JEDEC J-STD-020E.
4. Temperature tolerance: +0 °C, as measured at any point on the package or leads
5. MSL rating of 1 (SOT-23-3 only) compatible with J-STD-020 or equivalent.
6. MSL rating of 3 (LGA-4 and Leaded LGA-4) compatible with J-STD-020 or equivalent.
7. All temperatures refer to the center of the package, measured on the package body surface that is facing up during assembly reflow (e.g., live-bug). If parts are reflowed in other than the normal live bug assembly reflow orientation (i.e., dead-bug), T_p shall be within ± 2 °C of the live bug T_p and still meet the T_c requirements, otherwise, the profile shall be adjusted to achieve the latter. To accurately measure actual peak package body temperatures, refer to JEP140 for recommended thermocouple use.
8. Reflow profiles in this document are for classification/preconditioning and are not meant to specify board assembly profiles. Actual board assembly profiles should be developed based on specific process needs and board designs and should not exceed the parameters in this table.

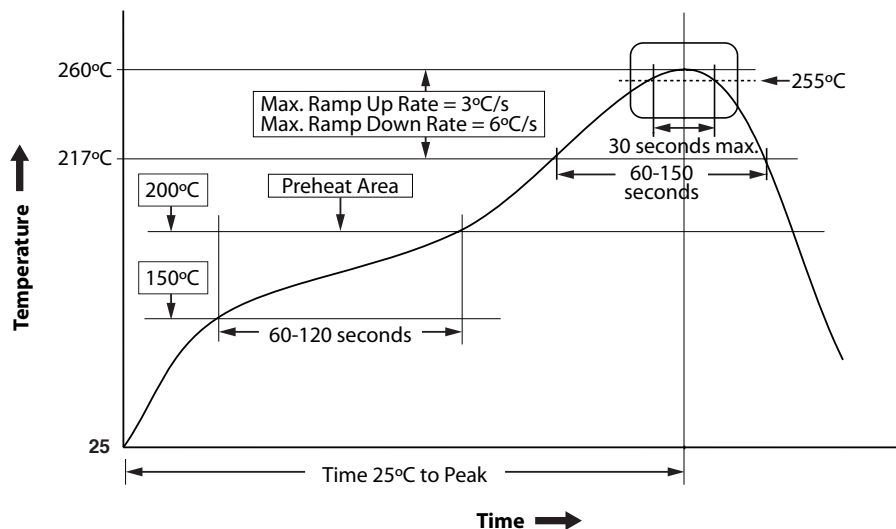

13 Suggested Solder Pad Layout

Dimensions in mm (inches)

13.1 SOT-23-3 Solder Pad Layout

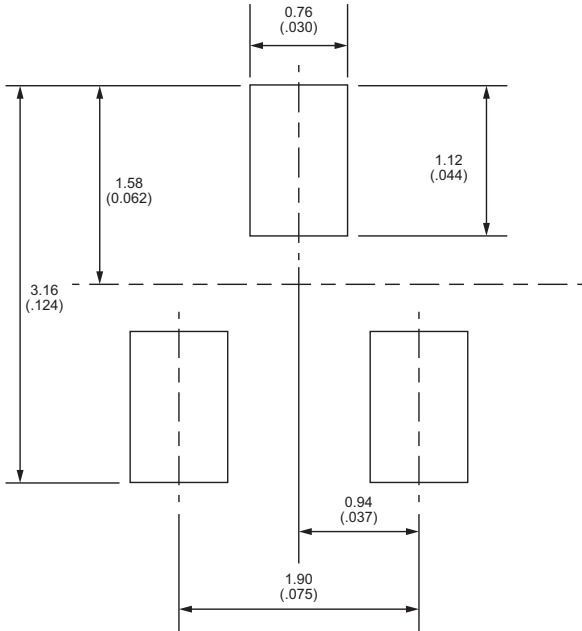

13.2 LGA-4 Solder Pad Layout

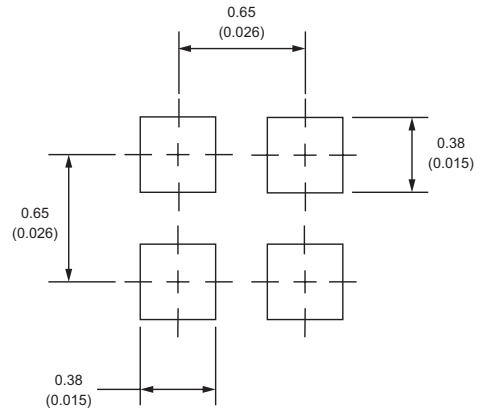

Revision History

| | Date | Description |
|----|------------|---|
| 1 | 10/13/2020 | Added Maximum Magnetic Field Exposure Value (Table 4.1) |
| 2 | 10/13/2020 | Modified Input and Output Current (Table 4.2) |
| 3 | 10/13/2020 | Modified UVLO Rise Value (Table 4.3) |
| 4 | 10/13/2020 | Modified UVLO Fall Value (Table 4.3) |
| 5 | 10/13/2020 | Added Supply Voltage, Typical (Table 4.3) |
| 6 | 10/13/2020 | Modified Switching Frequency MIN & MAX Values (Table 4.4) |
| 7 | 10/13/2020 | Modified Active Mode Time Value (Table 4.4) |
| 8 | 10/13/2020 | Added MIN & MAX Values to Idle Mode (Table 4.4) |
| 9 | 10/13/2020 | Modified Operate Point (BopN) MIN Value (Table 4.4) |
| 10 | 10/13/2020 | Modified Operate Point (BopS) MAX Value (Table 4.4) |
| 11 | 10/14/2020 | Modified Supply Voltage MAX Value (Table 4.2) |
| 12 | 09/14/2021 | Modified Magnetic Parameters (Table 4.4) |
| 13 | 09/14/2021 | Modified Output Response vs. Magnetic Flux Drawing (Section 5) |
| 14 | 09/14/2021 | Modified Output Behavior vs. Magnetic Field Diagrams (Section 10) |
| 15 | 09/14/2021 | Modified Axis of Sensitivity on LGA-4 (Section 7.2) |
| 16 | 10/29/2021 | Modified Operate Point and Release Point Values (Table 4.4) |
| 17 | 10/29/2021 | Modified Bottom View Dimensions (Section 8.2 LGA-4 Package) |
| 18 | 12/14/2021 | Deleted Superfluous Note 4 on Page 3 |
| | | |

X-ON Electronics

Largest Supplier of Electrical and Electronic Components

Click to view similar products for [Board Mount Hall Effect/Magnetic Sensors](#) category:

Click to view products by [Coto](#) manufacturer:

Other Similar products are found below :

[HGPRDT005A](#) [AH277AZ4-AG1](#) [AV-10379](#) [AV-10448](#) [SS41C](#) [AH1894-Z-7](#) [ATS601LSGTN-LT-WU4-T](#) [TLE4917](#) [50017859-003](#) [TY-13101](#) [TLE4976L](#) [AH49FNTR-G1](#) [SS85CA](#) [AH277AZ4-BG1](#) [TLE49614MXTSA1](#) [AH3377-P-B](#) [AH211Z4-AG1](#) [AH3360-FT4-7](#) [SS460S-100SAMPLE](#) [50065820-03](#) [TLE4941PLUSCB](#) [AH374-P-A](#) [AH1806-P-A](#) [SS460P-T2](#) [AH1913-W-7](#) [SS413F](#) [TLE5046ICAKLRHALA1](#) [TLE49421CHAMA2](#) [TLE4941PLUSCXAMA1](#) [AH1912-W-EVM](#) [AH1903-FA-EVM](#) [AH3774-W-EVM](#) [AH49FNTR-EVM](#) [MMC5633NJL](#) [AH3360-FA-EVM](#) [AH8502-FDC-EVM](#) [AH3366Q-SA-EVM](#) [AH3774-P-EVM](#) [KTH1601SU-ST3](#) [MG910](#) [MG910M](#) [MG911](#) [MG610](#) [MW921](#) [TLE4998S3XALA1](#) [TLE5011FUMA1](#) [TLE5027CE6747HAMA1](#) [TLE5109A16E2210XUMA1](#) [TLI4966GHTSA1](#) [TLI4906KHTSA1](#)