

1 Description

The RedRock® RR132-2E22-551 and RR132-2E23-551 are digital magnetic sensors ideal for use in medical, industrial, automotive, and consumer applications. They are based on patented Tunneling Magnetoresistance (TMR) technology with seamless CMOS integration.

The RR132-2E22-551 and RR132-2E23-551 feature an operate sensitivity of 15 G (1.5 mT), with a unipolar magnetic field response. They offer a wide supply voltage range from 1.7 up to 5.5 V, ideal for applications ranging from small battery-powered electronics to industrial machinery. They have the world's lowest average current drain (70nA) for an active magnetic sensor operating at 10 Hz and high operating temperature range from -40°C up to +125°C.

2 Features

- ▶ Operate sensitivity of 15 G
- ▶ Lowest Average Current of 70 nA
- ▶ Wide Supply Voltage range of 1.7V – 5.5V
- ▶ Unipolar Open-Drain Response
- ▶ Operating Frequency of 10 Hz
- ▶ Temperature Rated up to +125°C
- ▶ RoHS & REACH Compliant

3 Applications

- ▶ Proximity Detection
- ▶ Rotary Sensing
- ▶ Fluid Level Detection
- ▶ Door & Lid Closure Detection
- ▶ Utility Meters
- ▶ Portable Medical Devices
- ▶ Motor Controllers
- ▶ Consumer Electronics
- ▶ Wake-Up μ Processor

Device Information

Part Series	Package	Body Size (mm)	Temp Rating °C
RR132-2E22-551	SOT-23-3	2.9 x 1.6 x 1.2	-40 to +85
RR132-2E23-551	SOT-23-3	2.9 x 1.6 x 1.2	-40 to +125

Device Packages



Functional Block Diagram for Digital Open-Drain Output

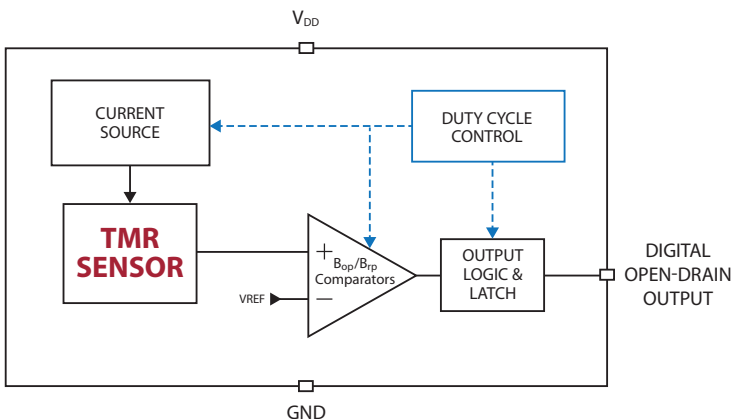

Device Nomenclature

Ordering Information

RR132-X X X X-YYY

Series	Package
Magnetic Polarity Response	1: SOT-23-3
1 = Omnipolar	2: LGA-4
2 = Unipolar	5: SOT-23-5
3 = Bipolar/Latch	Output Response
Magnetic Sensitivity (G)	5: Open Drain
A: Op 9, Rel 5	Supply Voltage (V)
B: Op 30, Rel 20	5: 1.7 - 5.5
C: Op 10, Rel -10	Temp Rating (°C)
Clock Frequency (Hz)	2: -40 - +85
1: 2	3: -40 - +125
5: 250	
9: 10000	
2: 10	
6: 500	
U: 100+Turbo (10000)	
3: 20	
7: 2500	

4 Specifications

4.1 Absolute Environmental Ratings^{1,2}

Parameters	Units	Min	Typ	Max
Operating Temperature (T _{OP}) (RR132-1B12-551)	°C	-40		+85
Operating Temperature (T _{OP}) (RR132-1B13-551)	°C	-40		+125
Storage Temperature (T _{STG})	°C	-65		+150
Junction Temperature (T _J)	°C			+150
Soldering Temperature (3 cycles, 1 min.) (T _{SOL})	°C			+260
ESD Level Human Body Model per JESD22-A114	V	±4000		
ESD Level Charged Device Model (CDM) per JESD22-C1010	V	±500		
Junction-to-Ambient Thermal Resistance (SOT-23-3)	°C/W		202	
Maximum Magnetic Field Exposure (B _{MAX})	G			±2000

4.2 Absolute Electrical Ratings^{1,2}

Parameters	Units	Min	Typ	Max
Supply Voltage (V _{DD})	V	-0.3		6.0
Open-Drain Output Voltage (Active Low)(V _{OUT-OD}) ³	V	-0.3		6.0
Input and Output Current (I _{IN} /I _{OUT})	mA			±20

4.3 Operating Electrical Characteristics for RR132-2E22-551 and RR132-2E23-551⁴

Parameters	Units	Min	Typ	Max
Supply Voltage (V _{DD})	V	1.7	3.0	5.5
Power-On Time (t _{ON})(V _{DD} > 90%)	μs		50	75
Peak Power-On Current	mA			1.4
Output Voltage (High) (V _{OUTH})	V	90% V _{DD}		
Output Voltage (Low) (V _{OUTL})	V			10% V _{DD}
Under Voltage Lockout Threshold Rising V _{DD} (V _{UVLO-RISE})	V		1.60	1.64
Under Voltage Lockout Threshold Falling V _{DD} (V _{UVLO-FALL})	V	1.44	1.53	
Under Voltage Lockout Hysteresis (V _{UV-HYST})	mV		70	
Average Supply Current @ V _{DD} =1.7 V, f _{SW} =10 Hz (I _{DDAVG}) ⁵	nA		70	900
Average Supply Current @ V _{DD} =3.0 V, f _{SW} =10 Hz (I _{DDAVG}) ⁵	nA		85	900

Notes:

- Exceeding Absolute Ratings may cause permanent damage to the device.
- Unless otherwise specified, all characteristics are measured at 25°C.
- V_{SYS} (Voltage source) for open-drain output should not exceed V_{DD} + 0.3V.
- Unless otherwise specified, V_{DD} = 1.7 V to 5.5 V, T_A = -40°C to +85°C (2E22), -40°C to +125°C (2E23). Typical values are V_{DD} = 3.0 V and T_A = +25°C.
- Conditions: t=10 seconds.



ESD Note: This product uses semiconductors that can be damaged by electrostatic discharge (ESD). When handling, proper ESD precautions should be taken to avoid performance degradation or loss of functionality. Damage due to inappropriate handling is not covered under warranty.

4 Specifications (cont.)

4.4 Operating Characteristics for RR132-2E22-551 and RR132-2E23-551¹

Parameters	Units	Min	Typ	Max
Switching Frequency (f_{SW})	Hz	6	10	14
Active Mode Time (t_{ACT})	μs		2.6	
Idle Mode Time @ $f_{SW}=10$ Hz (t_{IDLE})	ms	71	100	166
Operate Point (B_{OPS})	G	-19	-15	-11
Release Point (B_{RPS})	G	-14	-10	-6
Hysteresis (B_{HYST}) ²	G	3	5	

Notes:

1. Unless otherwise specified, $V_{DD} = 1.7$ V to 5.5 V, $T_A = -40^\circ C$ to $+85^\circ C$ (2E22), $-40^\circ C$ to $+125^\circ C$ (2E23). Typical values are $V_{DD} = 3.0$ V and $T_A = +25^\circ C$.

2. Conditions: $B_{HYST} = |B_{OP} - B_{RP}|$



ESD Note: This product uses semiconductors that can be damaged by electrostatic discharge (ESD). When handling, proper ESD precautions should be taken to avoid performance degradation or loss of functionality. Damage due to inappropriate handling is not covered under warranty.

5 Output Response vs. Magnetic Flux

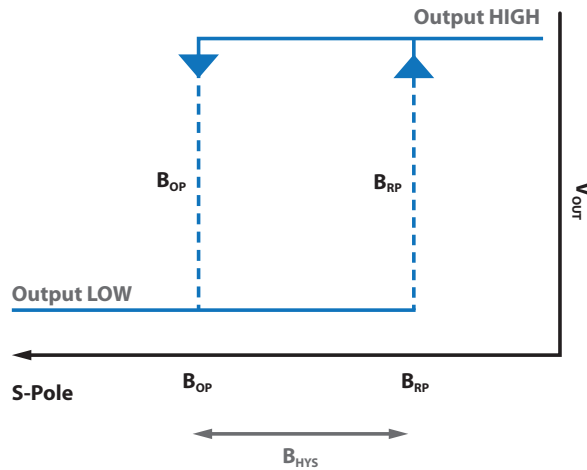

6 Application Information

RR132 Application Circuit

The output voltage of the RR132 is active low, meaning that while a sufficiently strong magnetic field is present, the output voltage is low. With the open-drain output, the system voltage can range from (V_{dd} + 0.3V) up to absolute max of 6.0Vdc. A decoupling capacitor between the supply voltage and ground is required with placement close to the magnetic sensor. A capacitor with a value of 1.0μF, placed not more than 10 mm from the sensor, is required.

Application Circuit (SOT-23-3)

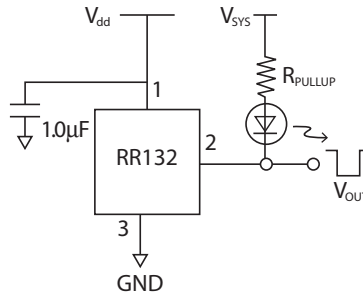

7 Axis of Sensitivity

SOT-23-3

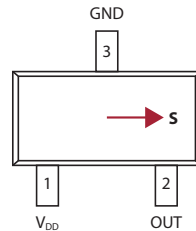

8 Dimensions *Millimeters (Inches)*

SOT-23-3 Package

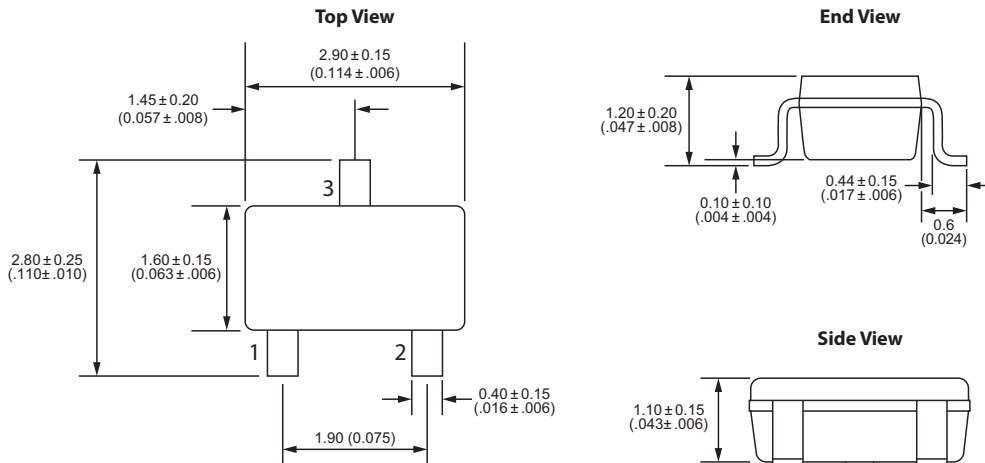

9 TMR Sensor Location

9.1 SOT-23-3 Package

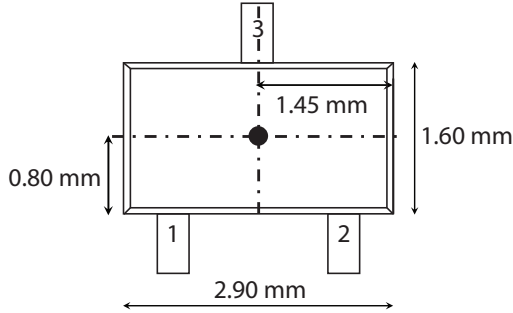

9.2 SOT Package - Side View

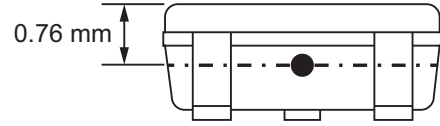

10 Output Behavior vs. Magnetic Field Diagrams

Output Behavior vs. Magnetic Field - Unipolar

Characteristics	Conditions	Output
South Pole	$B < B_{OPS}$ $0 > B > B_{RPS}$	Low (ON) High (OFF)

11 TMR Sensor & Switch Packaging

11.1 SOT-23-3 Tape & Reel Packaging

Standard packaging is Tape & Reel containing 3,000 pieces. MSL Rating is 1.

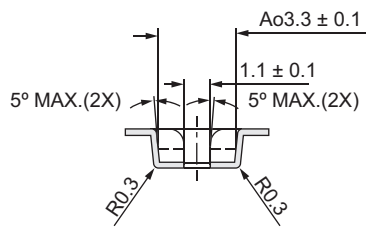
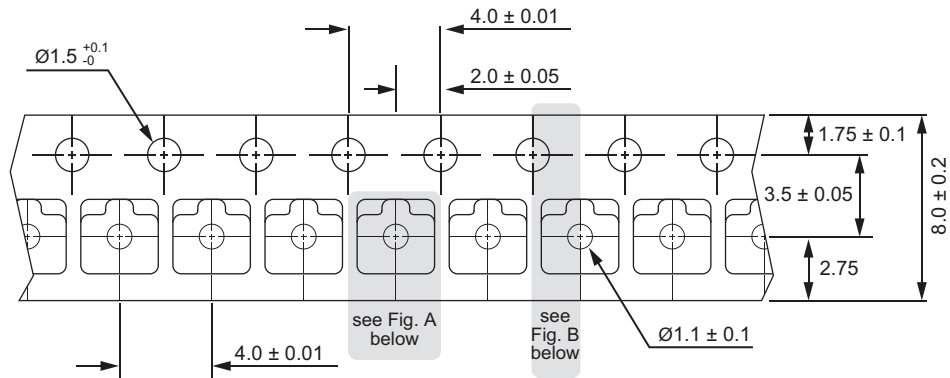

Fig. A

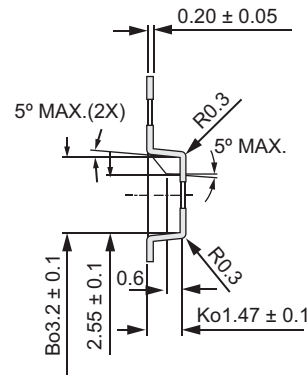
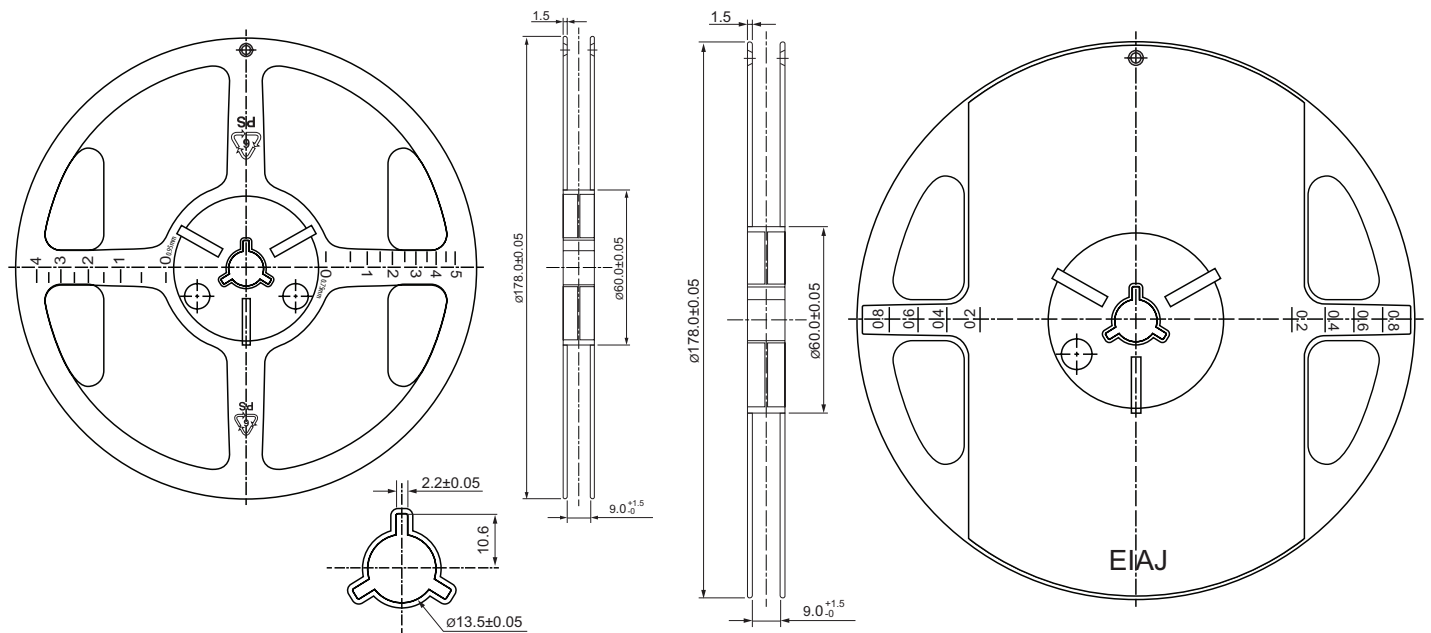

Fig. B



11 TMR Sensor & Switch Packaging

11.3 RedRock TMR Packaging

Box Dimensions – 14x10x6 inches

- Fits 1 to 3 reels = 3000 to 9000 pcs
- Weight for 3000 pcs = 0.90 kilos
- Weight for 9000 pcs = 1.00 kilos

Box Dimensions – 18x14x12 inches

- Fits 4 to 24 reels = 12000 to 72000 pcs
- Weight for 12000 pcs = 1.50 kilos
- Weight for 72000 pcs = 4.90 kilos

12 Suggested Pb-Free Reflow Profile

Notes:

1. Fully compatible with standard no-lead solder profile, 260°C for 30 seconds max (3 cycles max).
2. Profile shown as example. Users are advised to develop their own board-level profile.
3. Suggested Pb-free reflow profile derived from IPC/JEDEC J-STD-020E.
4. Temperature tolerance: +0°C, as measured at any point on the package or leads
5. MSL rating of 1 (SOT-23-3 only) compatible with J-STD-020 or equivalent.
6. All temperatures refer to the center of the package, measured on the package body surface that is facing up during assembly reflow (e.g., live-bug). If parts are reflowed in other than the normal live bug assembly reflow orientation (i.e., dead-bug), T_p shall be within $\pm 2^\circ\text{C}$ of the live bug T_p and still meet the T_c requirements, otherwise, the profile shall be adjusted to achieve the latter. To accurately measure actual peak package body temperatures, refer to JEP140 for recommended thermocouple use.
7. Reflow profiles in this document are for classification/preconditioning and are not meant to specify board assembly profiles. Actual board assembly profiles should be developed based on specific process needs and board designs and should not exceed the parameters in this table.

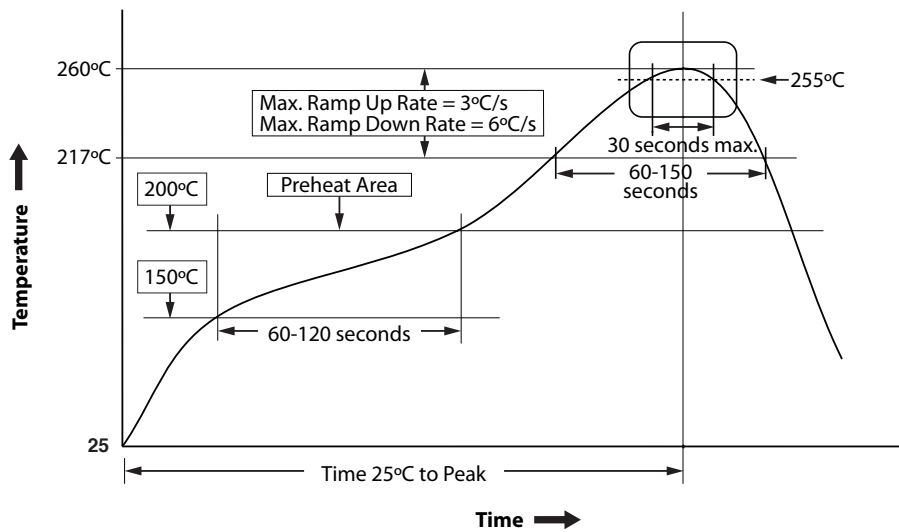

13 Suggested Solder Pad Layout

Dimensions in mm (inches)

SOT-23-3 Solder Pad Layout

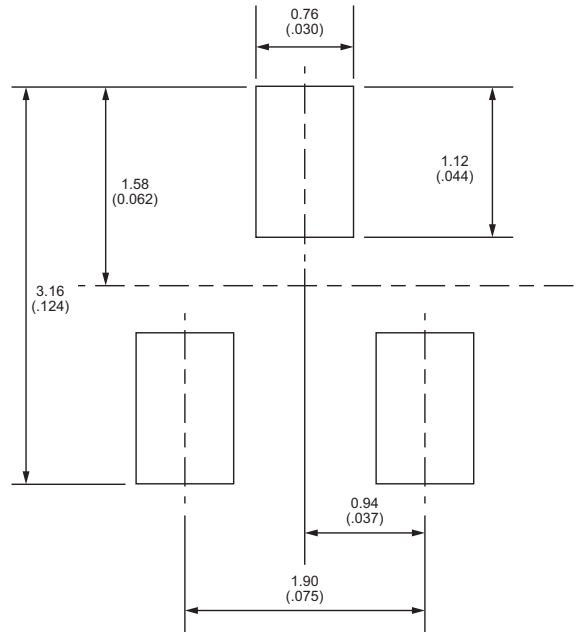

X-ON Electronics

Largest Supplier of Electrical and Electronic Components

Click to view similar products for [Board Mount Temperature Sensors](#) category:

Click to view products by [Coto](#) manufacturer:

Other Similar products are found below :

[5962-8757102XA](#) [66F115](#) [EMC1063-1-ACZL-TR](#) [NCT218FCT2G](#) [O53GAB175A-160Y](#) [3610085020002](#) [389049M9527](#) [MIKROE-912](#)
[ADM1023ARQZ-REEL](#) [ADM1032ARMZ-1RL](#) [AT30TS74-U1FMBB-T](#) [AT30TS74-U1FMAB-T](#) [AT30TS74-U1FMCB-T](#) [AT30TS74-](#)
[U1FMDB-T](#) [ADT7483AARQZ-RL](#) [ADT7481ARMZ-REEL](#) [ADT7463ARQZ-REEL](#) [MCP98243T-BE/MC](#) [66L080-0226](#) [5962-8757103XA](#)
[S-58LM20A-I4T1U](#) [NCT375MNR2G](#) [LM84CIMQA](#) [CAT34TS00VP2GT4A](#) [NCT80DBR2G](#) [SEN-16304](#) [MAX31875R5TZS+T](#)
[MAX31875R6TZS+T](#) [AR550/U](#) [AR550/I](#) [MAX-SSD240](#) [MAX-SSD480](#) [MAX-MB-DS-10](#) [MAX-MB-TC-1](#) [TC6501P065VCTTR](#) [AT-1U](#)
[MCP9700AT-E/LT](#) [MCP9701-E/TO](#) [MCP9803-M/MS](#) [MCP9701A-E/TO](#) [MCP9701AT-E/LT](#) [LM57FEPWQ1](#) [LM57FPW](#) [LM57FSPWQ1](#)
[60-41123102-0150.0010](#) [60-43123102-0150.0010](#) [60-53123102-0150.0010](#) [TMP303CDRLR](#) [TC6501P055VCTTR](#) [ADT7311WTRZ-RL](#)