

XLamp® XP-G3 Photophyll™ Select LEDs

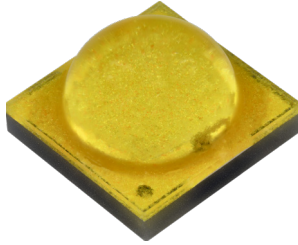

PRODUCT DESCRIPTION

Photophyll™ Select LEDs feature an advanced horticulture spectrum with blue and green output tuned for horticulture applications. Photophyll Select LEDs are designed to replace the white LEDs that are common in two-channel white + red horticulture luminaires. By maximizing green content and minimizing red content versus standard lighting LEDs, this LED color enables significant enhancements to luminaire cost and performance.

Photophyll Select LEDs are the industry's first LEDs to be entirely binned in horticulture metrics, enabling more straightforward spectrum design without confusing translations or conversions. The spectral output of these LEDs is binned into two metrics, both of which are based on the amount of PPF in standard blue (400-500 nm), green (500-600 nm) and red (600-700 nm) bands. The two spectral metrics are the percentage of red PPF content (Red PPF %) and the ratio of green to blue PPF content (Green/Blue Ratio or GBR).

XLamp XP-G3 Photophyll Select LEDs combine this new color and the many strengths of the XP-G3 platform, including efficiency, long-term reliability, convenient design ecosystem and optical control.

FEATURES

- Maximum drive current: 2000 mA
- Low thermal resistance: 0.7 °C/W
- Wide viewing angle: 125°
- Unlimited floor life at ≤ 30 °C/85% RH
- Reflow solderable - JEDEC J-STD-020C
- Electrically neutral thermal path
- RoHS and REACH compliant
- UL® recognized component (E349212)



Cree LED / 4001 E. Hwy. 54, Suite 2000 / Durham, NC 27709 USA / +1.919.313.5330 / www.cree-led.com

TABLE OF CONTENTS

Characteristics 3

Order Codes..... 4

Relative Spectral Power Distribution 5

Relative PPF vs. Junction Temperature..... 5

Electrical Characteristics..... 6

Relative PPF vs. Current 6

Typical Spatial Distribution..... 7

Thermal Design 7

Bin and Order Code Formats 8

Reflow Soldering Characteristics..... 9

Notes 10

Mechanical Dimensions 12

Tape and Reel..... 14

Packaging..... 16

CHARACTERISTICS

| Characteristics | Unit | Minimum | Typical | Maximum |
|--|---------|---------|----------|---------|
| Thermal resistance* | °C/W | | 0.7 | |
| Viewing angle (FWHM) | degrees | | 125 | |
| Temperature coefficient of voltage | mV/°C | | -1.3 | |
| ESD withstand voltage (HBM per Mil-Std-883D) | | | Class 3B | |
| DC forward current | mA | | | 2000 |
| Reverse voltage | V | | | 1 |
| Forward voltage (@ 350 mA, 25 °C) | V | | 2.82 | 3 |
| LED junction temperature | °C | | | 150 |

* Thermal resistance measurement was performed per the JEDEC JESD51-14 standard. See the [Thermal Resistance Measurement application note](#) for more details.

ORDER CODES - T_j = 25 °C

The following table provides order codes for XLamp XP-G3 Photophyll Select LEDs. For a complete description of the order code nomenclature, please see the Bin and Order Code Formats section (page 8).

| Color | Red PPF % | Green/Blue Ratio (GBR) | GBR Code | PPF Code | PPF @ 350 mA (µmol/s) | | Calculated PPE @ 350 mA (µmol/J) | | Order Code |
|-------------------|-----------|------------------------|----------|----------|-----------------------|---------|----------------------------------|---------|----------------------|
| | | | | | Minimum | Typical | Minimum | Typical | |
| Photophyll Select | 20% | 2.0 | N | V | 2 | 2.25 | 2.02 | 2.27 | XPGDWT-N1-0000-00VPP |
| | | | | X | 2.5 | 2.6 | 2.52 | 2.62 | XPGDWT-N1-0000-00XPP |
| | | 2.5 | Q | V | 2 | 2.25 | 2.02 | 2.27 | XPGDWT-Q1-0000-00VPP |
| | | | | X | 2.5 | 2.6 | 2.52 | 2.62 | XPGDWT-Q1-0000-00XPP |
| | | 3.0 | X | V | 2 | 2.25 | 2.02 | 2.27 | XPGDWT-X1-0000-00VPP |
| | | | | X | 2.5 | 2.6 | 2.52 | 2.62 | XPGDWT-X1-0000-00XPP |

The following table provides order codes for XLamp XP-G3 Photophyll Select S Line LEDs. For a complete description of the order code nomenclature, please see the Bin and Order Code Formats section (page 8).

| Color | Red PPF % | Green/Blue Ratio (GBR) | GBR Code | PPF Code | PPF @ 350 mA (µmol/s) | | Calculated PPE @ 350 mA (µmol/J) | | Order Code |
|-------------------|-----------|------------------------|----------|----------|-----------------------|---------|----------------------------------|---------|----------------------|
| | | | | | Minimum | Typical | Minimum | Typical | |
| Photophyll Select | 20% | 2.0 | N | V | 2 | 2.25 | 2.02 | 2.27 | XPGDWT-NS-0000-00VPP |
| | | | | X | 2.5 | 2.6 | 2.52 | 2.62 | XPGDWT-NS-0000-00XPP |
| | | 2.5 | Q | V | 2 | 2.25 | 2.02 | 2.27 | XPGDWT-QS-0000-00VPP |
| | | | | X | 2.5 | 2.6 | 2.52 | 2.62 | XPGDWT-QS-0000-00XPP |
| | | 3.0 | X | V | 2 | 2.25 | 2.02 | 2.27 | XPGDWT-XS-0000-00VPP |
| | | | | X | 2.5 | 2.6 | 2.52 | 2.62 | XPGDWT-XS-0000-00XPP |

Notes

- Red PPF % is calculated as the ratio of Red photon flux (600-700 nm) to total PPF (400-700 nm). Tolerance for Red PPF % is ±2.5%.
- GBR: Green/Blue Ratio is calculated as the ratio of Green photon flux (500-600 nm) to Blue photon flux (400-500 nm). Tolerance for GBR is ±0.5.
- PPF is a photon flux measurement in the 400-700 nm range
- PPE values are calculated and for reference only.
- Cree LED maintains a tolerance of ±7% on PPF measurements. See the Measurements section (page 10).

RELATIVE SPECTRAL POWER DISTRIBUTION

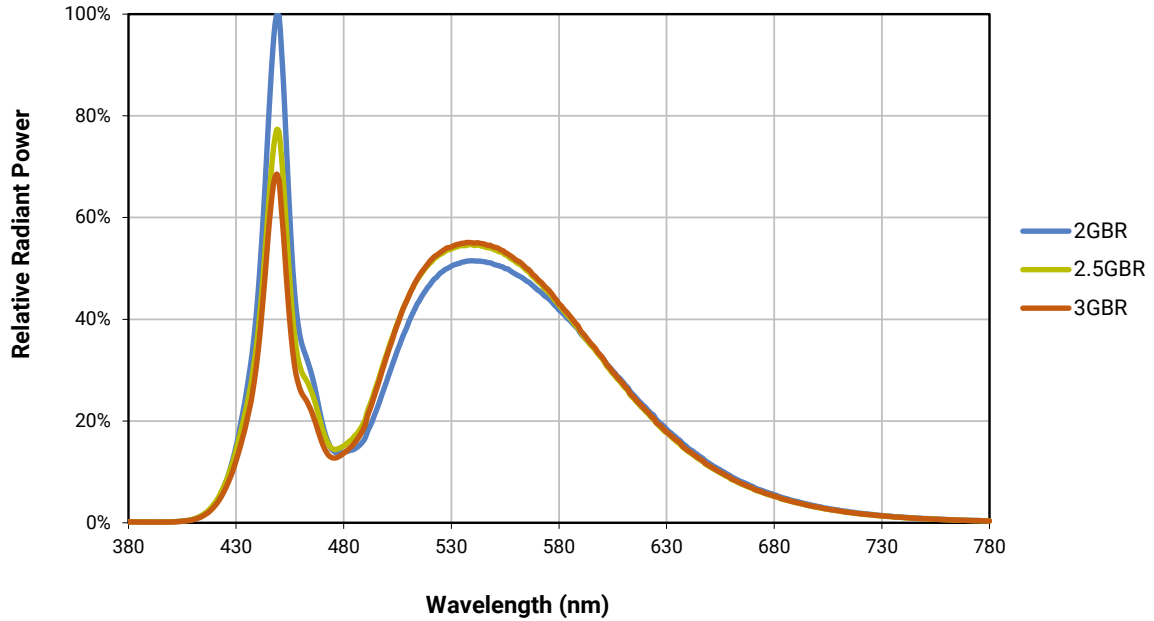

RELATIVE PPF VS. JUNCTION TEMPERATURE - $I_f = 350 \text{ mA}$

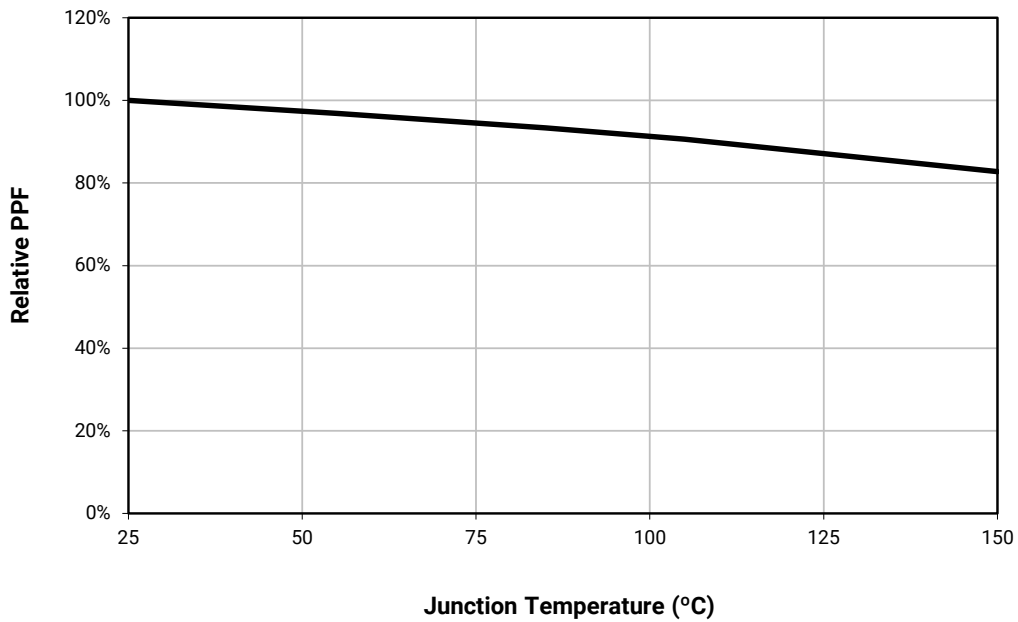

ELECTRICAL CHARACTERISTICS - $T_j = 25\text{ }^\circ\text{C}$

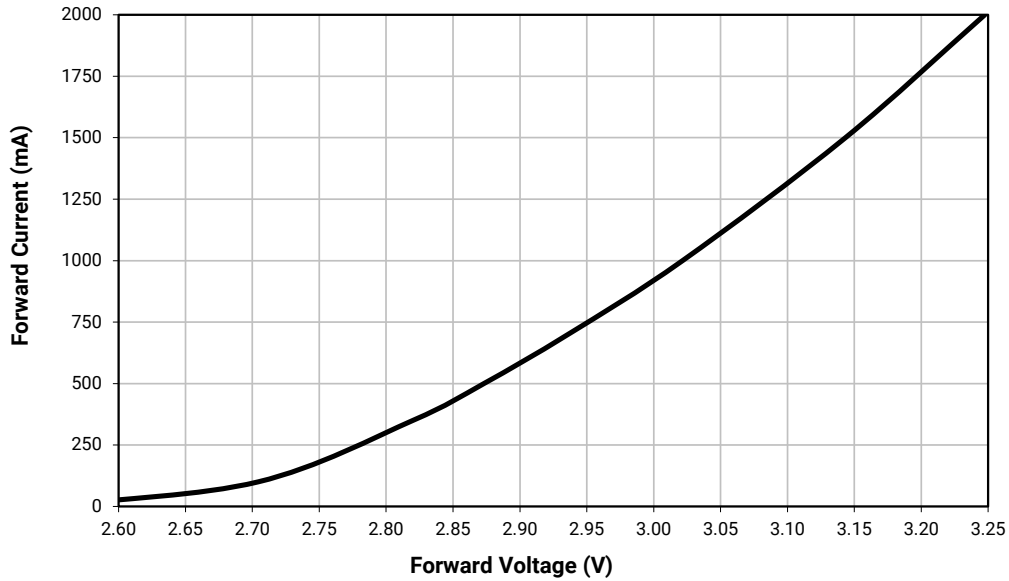

RELATIVE PPF VS. CURRENT - $T_j = 25\text{ }^\circ\text{C}$

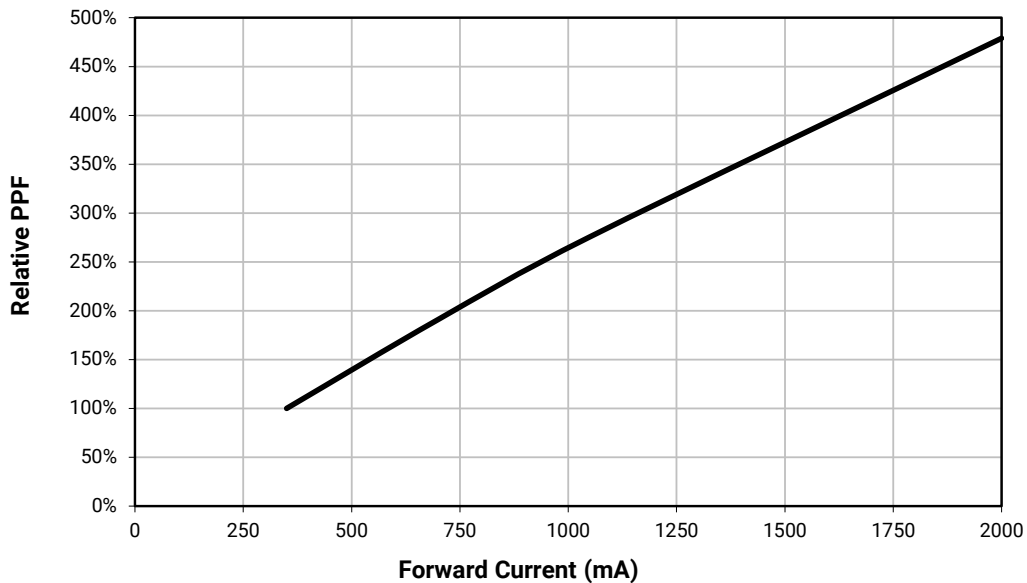

TYPICAL SPATIAL DISTRIBUTION

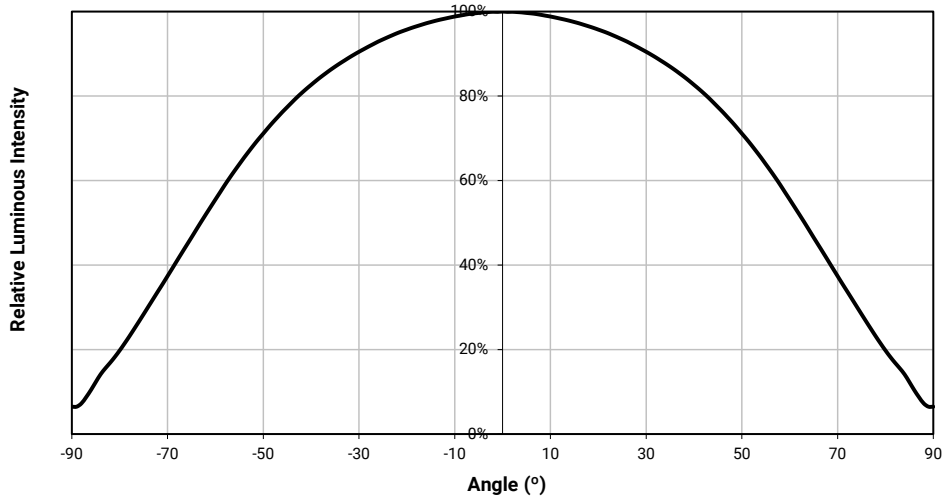

THERMAL DESIGN

The maximum forward current is determined by the thermal resistance between the LED junction and ambient. It is crucial for the end product to be designed in a manner that minimizes the thermal resistance from the solder point to ambient in order to optimize lamp life and optical characteristics.

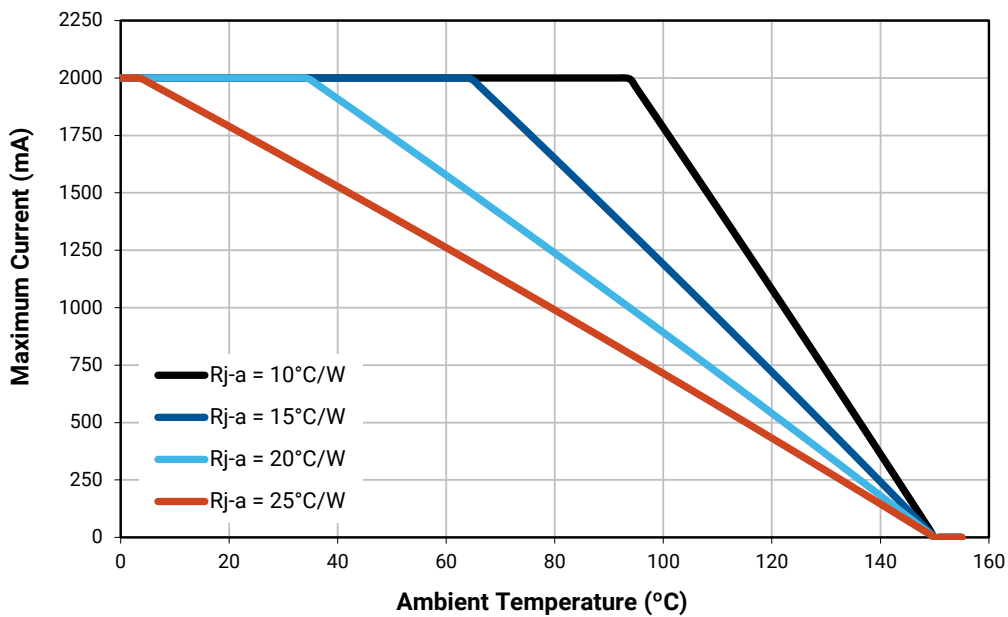

BIN AND ORDER CODE FORMATS

XP-G3 Photophyll Select bin codes and order codes are configured in the following manner:

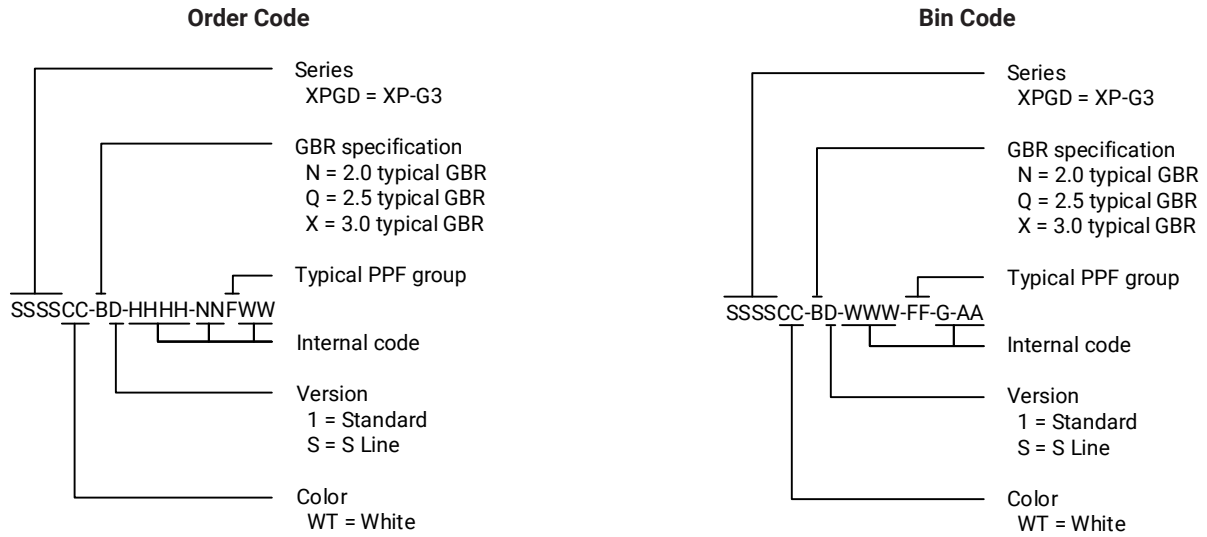

REFLOW SOLDERING CHARACTERISTICS

In testing, Cree LED has found XLamp XP-G3 Photophyll Select LEDs to be compatible with JEDEC J-STD-020C, with the exception of the peak temperature requirements listed in the table below. As a general guideline, Cree LED recommends that users follow the recommended soldering profile provided by the manufacturer of the solder paste used, and therefore it is the lamp or luminaire manufacturer’s responsibility to determine applicable soldering requirements.

Note that this general guideline may not apply to all PCB designs and configurations of reflow soldering equipment.

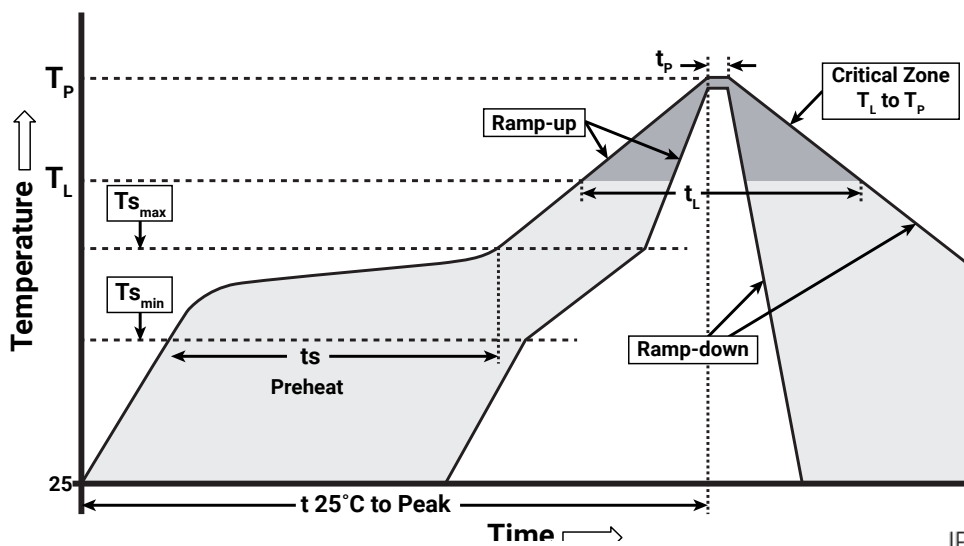

IPC/JEDEC J-STD-020C

| Profile Feature | Lead-Free Solder |
|---|------------------|
| Average Ramp-Up Rate ($T_{s_{max}}$ to T_p) | 1.2 °C/second |
| Preheat: Temperature Min ($T_{s_{min}}$) | 120 °C |
| Preheat: Temperature Max ($T_{s_{max}}$) | 170 °C |
| Preheat: Time ($t_{s_{min}}$ to $t_{s_{max}}$) | 65-150 seconds |
| Time Maintained Above: Temperature (T_L) | 217 °C |
| Time Maintained Above: Time (t_L) | 45-90 seconds |
| Peak/Classification Temperature (T_p) | 235 - 245 °C |
| Time Within 5 °C of Actual Peak Temperature (t_p) | 20-40 seconds |
| Ramp-Down Rate | 1 - 6 °C/second |
| Time 25 °C to Peak Temperature | 4 minutes max. |

Note: All temperatures refer to topside of the package, measured on the package body surface.

NOTES

Measurements

The PPF, GBR and Red PPF % measurements in this document are binning specifications only and solely represent product measurements as of the date of shipment. These measurements will change over time based on a number of factors that are not within Cree LED's control and are not intended or provided as operational specifications for the products. Calculated values are provided for informational purposes only and are not intended or provided as specifications.

Pre-Release Qualification Testing

Please read the [LED Reliability Overview](#) for details of the qualification process Cree LED applies to ensure long-term reliability for XLamp LEDs and details of Cree LED's pre-release qualification testing for XLamp LEDs. Cree LED did not perform Room Temperature Operating Life (RTOL) testing on the XP-G3 Photophyll Select LED.

Photon Flux Maintenance

Cree LED now uses standardized IES LM-80-08 and TM-21-11 methods for collecting long-term data and extrapolating LED photon flux maintenance. For information on the specific LM-80 data sets available for this LED, refer to the public [LM-80 results document](#).

Please read the [Long-Term Lumen Maintenance application note](#) for more details on Cree LED's lumen maintenance testing and forecasting. Please read the [Thermal Management application note](#) for details on how thermal design, ambient temperature, and drive current affect the LED junction temperature.

Moisture Sensitivity

Cree LED recommends keeping XLamp LEDs in the provided, resealable moisture-barrier packaging (MBP) until immediately prior to soldering. Unopened MBPs that contain XLamp LEDs do not need special storage for moisture sensitivity.

Once the MBP is opened, XLamp XP-G3 Photophyll Select LEDs may be stored as MSL 1 per JEDEC J-STD-033, meaning they have unlimited floor life in conditions of ≤ 30 °C/85% relative humidity (RH). Regardless of the storage condition, Cree LED recommends sealing any unsoldered LEDs in the original MBP.

RoHS Compliance

The levels of RoHS restricted materials in this product are below the maximum concentration values (also referred to as the threshold limits) permitted for such substances, or are used in an exempted application, in accordance with EU Directive 2011/65/EC (RoHS2), as implemented January 2, 2013. RoHS Declarations for this product can be obtained from your Cree LED representative or from the [Product Ecology](#) section of the Cree LED website.

REACH Compliance

REACH substances of very high concern (SVHCs) information is available for this product. Since the European Chemical Agency (ECHA) has published notice of their intent to frequently revise the SVHC listing for the foreseeable future, please contact a Cree LED representative to insure you get the most up-to-date REACH Declaration. REACH banned substance information (REACH Article 67) is also available upon request.

NOTES - CONTINUED

UL® Recognized Component

This product meets the requirements to be considered a UL Recognized Component with Level 4 enclosure consideration. The LED package or a portion thereof has been investigated as a fire and electrical enclosure per ANSI/UL 8750.

Vision Advisory

WARNING: Do not look at an exposed lamp in operation. Eye injury can result. For more information about LEDs and eye safety, please refer to the [LED Eye Safety application note](#).

MECHANICAL DIMENSIONS (T_A = 25 °C)

Thermal vias, if present, are not shown on these drawings.

All measurements are ±.13 mm unless otherwise indicated.

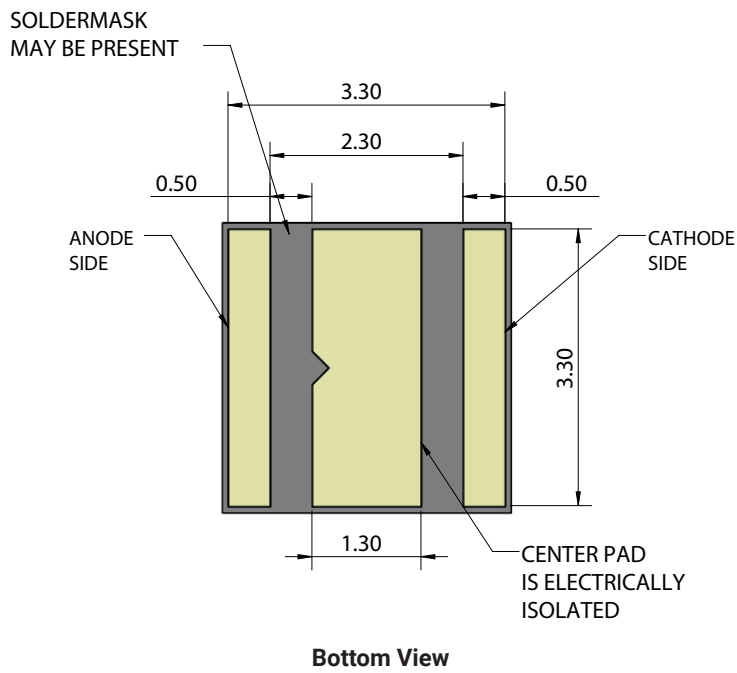
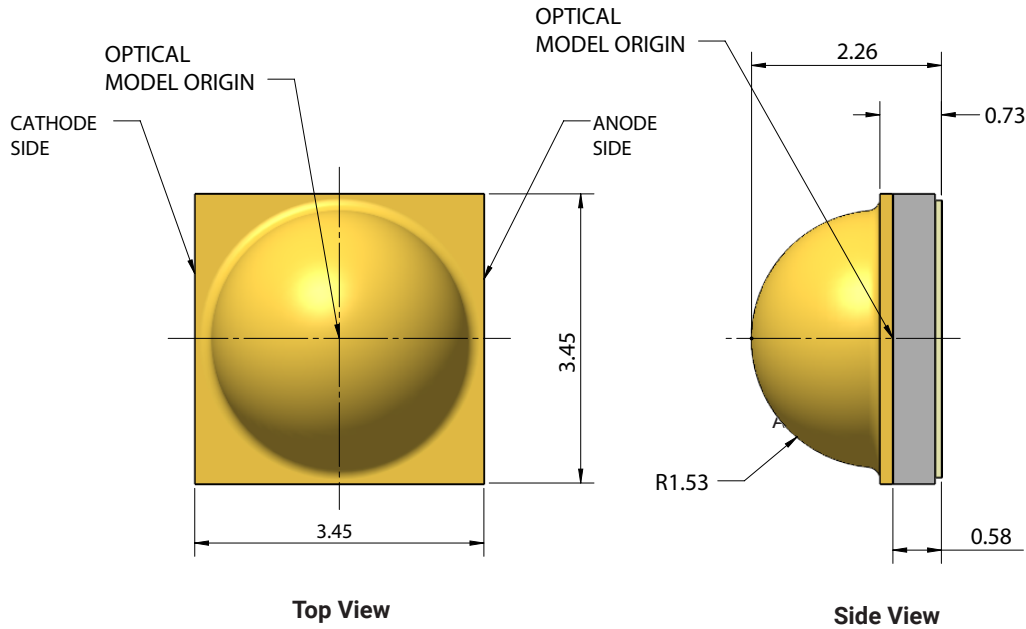

MECHANICAL DIMENSIONS (T_A = 25 °C) - CONTINUED

Thermal vias, if present, are not shown on these drawings.

All measurements are ±.13 mm unless otherwise indicated.

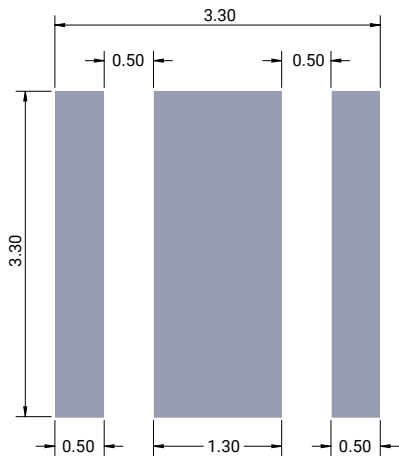

Recommended PCB Footprint

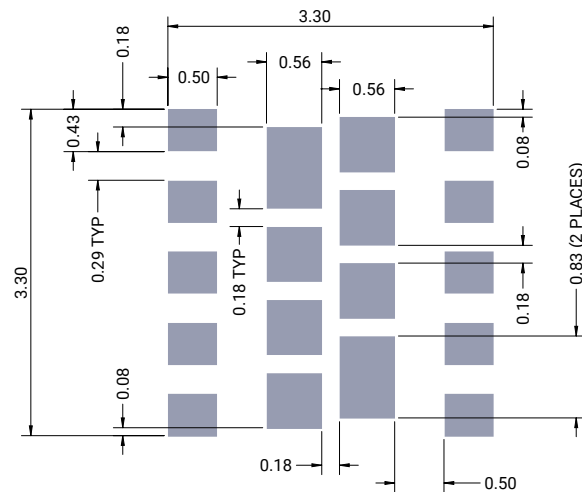

Recommended Stencil Openings*

Notes:

- Cree LED recommends using thermal pad kickouts to maximize component thermal performance.
- Cree LED recommends using white solder mask material to minimize system optical loss.
- * This stencil has been tested and optimized for the avoidance of voiding when using ALPHA® LUMET® P30 Maxrel solder paste. For other solder pastes, a “window pane” design for the thermal pad stencil may result in a lower voiding percentage. Contact your local Cree LED Field Applications Engineer for consultation regarding your specific application.

TAPE AND REEL

All Cree LED carrier tapes conform to EIA-481D, Automated Component Handling Systems Standard.

All dimensions in mm.

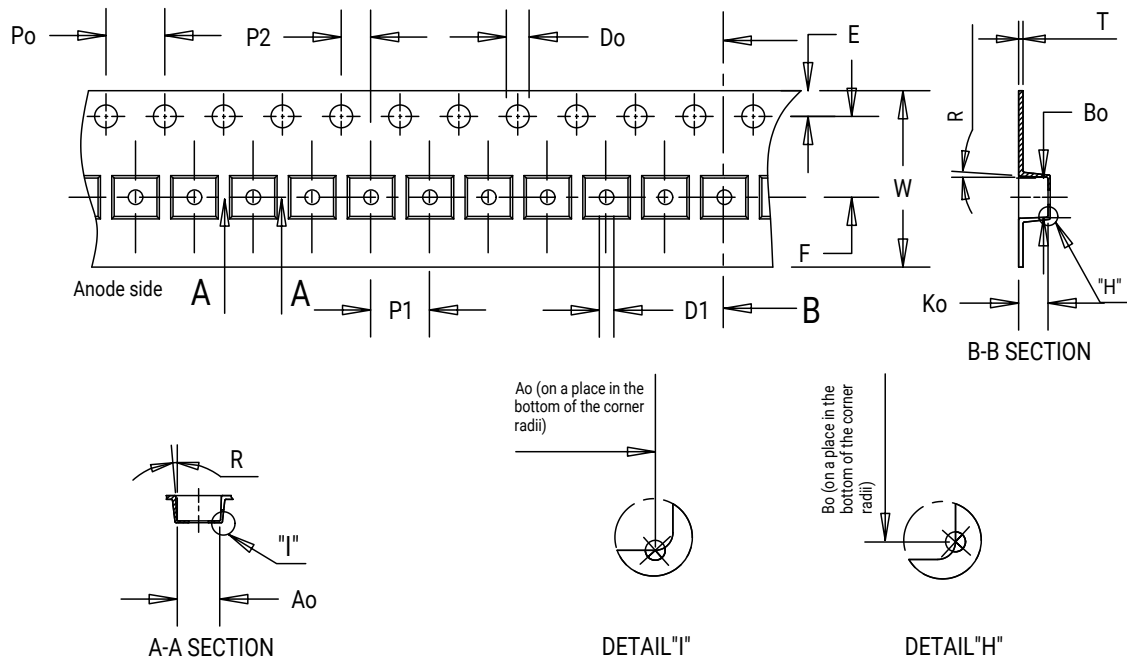

| Item | Ao | Bo | Ko | Po | P1 | P2 | T | E | F | Do | D1 | W | R |
|------|------|------|------|------|------|------|------|------|------|------|------|-------|----|
| Dim. | 3.70 | 3.70 | 2.40 | 4.00 | 8.00 | 2.00 | 0.30 | 1.75 | 5.50 | 1.55 | 1.50 | 12.00 | 5° |

TAPE AND REEL - CONTINUED

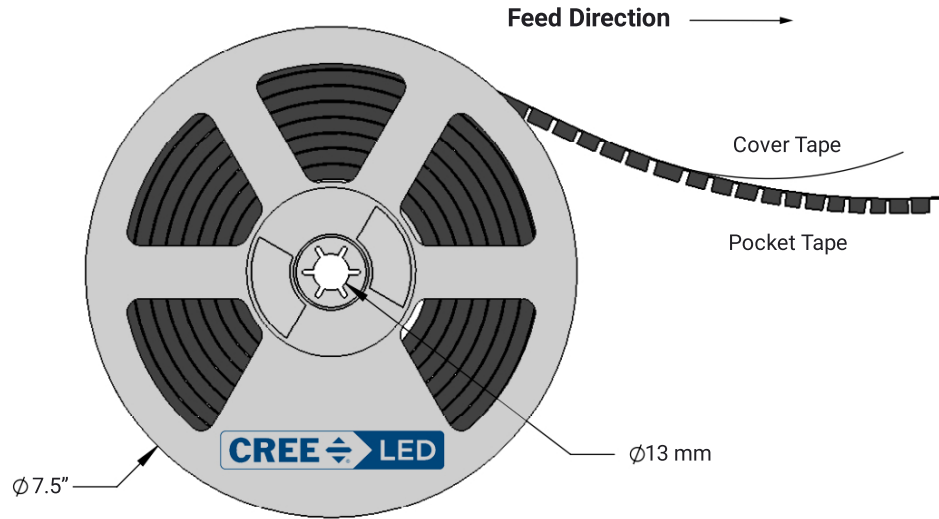
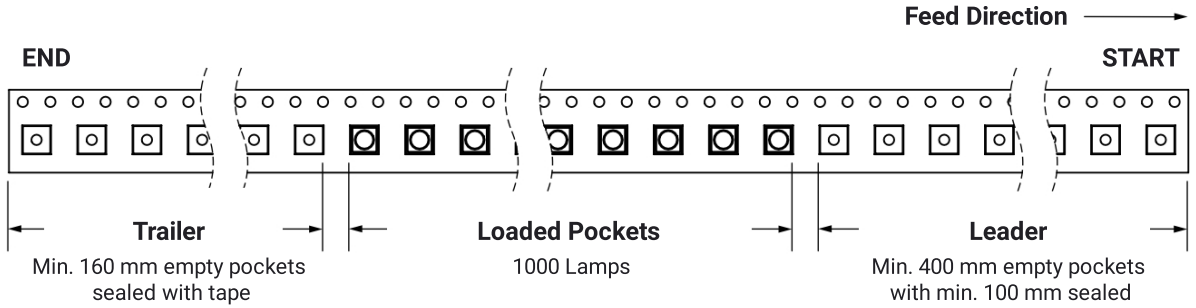

PACKAGING

Unpackaged Reel

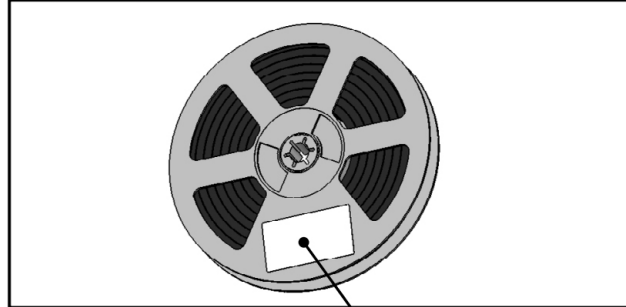

Label with Cree LED Bin Code, Quantity, Reel ID

Packaged Reel

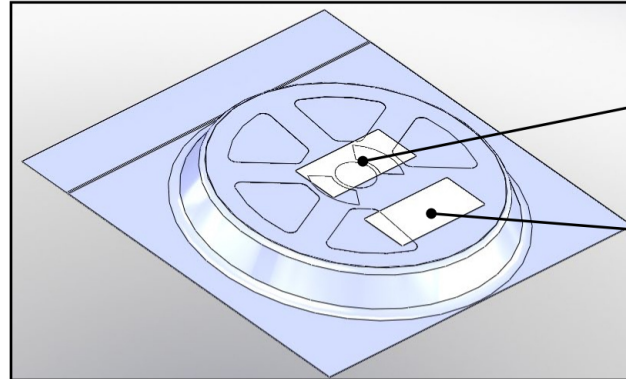

Label with Cree LED Order Code, Quantity, Reel ID, PO#

Label with Cree LED Bin Code, Quantity, Reel ID

Boxed Reel

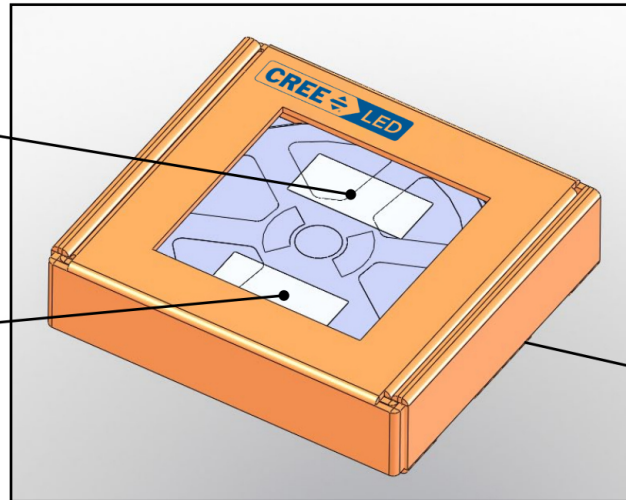

Label with Cree LED Order Code, Quantity, Reel ID, PO#

Label with Cree LED Bin Code, Quantity, Reel ID

Patent Label (on bottom of box)

X-ON Electronics

Largest Supplier of Electrical and Electronic Components

Click to view similar products for [High Power LEDs - White category:](#)

Click to view products by [Cree manufacturer:](#)

Other Similar products are found below :

[LTW-K140SZR40](#) [LTPL-P00DWS57](#) [LTW-K140SZR30](#) [LZP-D0WW00-0000](#) [JK2835AWT-00-0000-000B0HL227E-BLK](#) [LTW-K140SZR57](#) [LTW-K140SZR27](#) [BXRC-35E10K0-D-73](#) [MP-5050-6100-65-80](#) [KW CSLPM2.CC-8L8M-4L8N](#) [KW CSLPM2.CC-8L8M-4O9Q](#) [KW DPLS32.SB-6H6J-E5P7-EG-Z264](#) [L1V1-507003V500000](#) [BXRE-27E1000-C-83](#) [BXRE-27G0800-D-83](#) [BXRE-27G2000-B-83](#) [BXRE-50C2001-C-84](#) [BXRH-35S1001-B-73](#) [BXRH-30E0300-B-83](#) [BXRH-30E1000-G-83](#) [115780](#) [LM1311D4W-12B4C12\(Ra4\)-DS](#) [ELJU\(9\)-K40M3-0LTHE-R4000](#) [ELJU\(9\)-K40M3-0LTHE-R3000](#) [LM1311D4W-12B2C24\(Ra4\)-DS](#) [KW2 CFLNM2.TK-D2D9-4L07M0-SC6B](#) [XEGAWT-H2-0000-000-00000UT122G](#) [XHP35B-H0-0000-0D0ZA230G](#) [XHP35B-H0-0000-0D0ZA440G](#) [XHP35B-H0-0000-0D0ZA227G](#) [XHP35B-H0-0000-0D0ZA235G](#) [CTM-9-4018-90-36-TWD6-F3-3](#) [CVM-32-56-95-54-AC00-F2-2](#) [SST-12-W65S-A120-H4652](#) [CXM-4-24-90-18-AC40-F5-2](#) [CXM-4-22-90-18-AC40-F5-2](#) [LM002H384W-7B3C12\(Ra5\)\(ANSI-2700K\)](#) [LM002H384W-9B4C12\(Ra2\)\(ANSI-2700K\)](#) [LM002H384W-7B3C12\(Ra7\)\(ANSI-2700K\)](#) [LM002H384W-9B4C12\(Ra2\)\(ANSI-3000K\)](#) [LM002H384W-9B4C12\(Ra4\)-S\(ANSI-3500K\)](#) [LM002H384W-9B4C12\(Ra5\)\(ANSI-4000K\)](#) [LM002H384W-7B3C12\(Ra2\)-S\(ANSI-3000K\)](#) [LM002H384W-7B3C12\(Ra5\)\(ANSI-4000K\)](#) [LM002H384W-7B3C12\(Ra7\)\(ANSI-4000K\)](#) [HL-LM002H384W-5B2C5\(Ra4\)\(ANSI-3000K\)](#) [HL-LM002H384W-7B1C18\(Ra4\)\(ANSI-6000K\)](#) [LM002H384W-7B3C12\(Ra5\)\(ANSI-3500K\)](#) [HL-LM002H384W-5B2C5\(Ra4\)\(ANSI-4000K\)](#) [HL-LM002H384W-5B2C5\(Ra4\)\(ANSI-6000K\)](#)