

Features

- CRM(CQ) Super_Junction technology
- Much lower Ron*A performance for On-state efficiency
- Much lower FOM for fast switching efficiency

Applications

- LED/LCD/PDP TV and monitor Lighting
- Solar/Renewable/UPS-Micro Inverter System
- Charger
- Power Supply

Product Summary

V _{DS}	650V
R _{DS(on)_typ}	81mΩ
I _D	35A

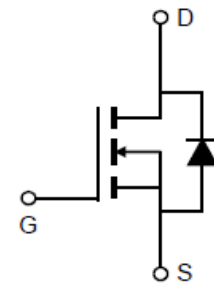
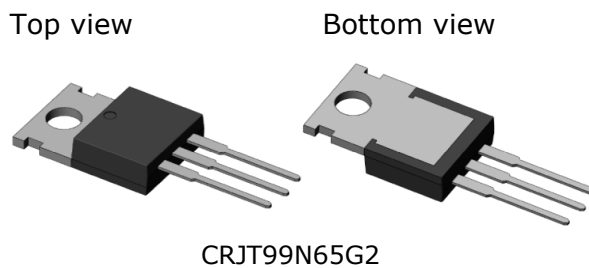
100% DVDS Tested
100% Avalanche Tested

Package Marking and Ordering Information

Part #	Marking	Package	Packing	Reel Size	Tape Width	Qty
CRJT99N65G2	-	TO-220	Tube	N/A	N/A	50pcs

Absolute Maximum Ratings

Parameter	Symbol	Value	Unit
Drain-source voltage	V _{DS}	650	V
Continuous drain current T _C = 25°C T _C = 100°C	I _D	35 22	A
Pulsed drain current (T _C = 25°C, t _p limited by T _{jmax})	I _{D pulse}	140	A
Avalanche energy, single pulse (L=60mH, R _g =30Ω)	E _{AS}	480	mJ
Gate-Source voltage	V _{GS}	±30	V
Power dissipation (T _C = 25°C)	P _{tot}	252	W
Operating junction and storage temperature	T _j , T _{stg}	-55...+150	°C

Thermal Resistance

Parameter	Symbol	Value			Unit	Test Condition
		min.	typ.	max.		
Thermal resistance, junction – case. Max	RthJC	-	0.354	0.50	°C/W	
Thermal resistance, junction – ambient. Max	RthJA	-	-	75	°C/W	

Electrical Characteristic (at T_j = 25 °C, unless otherwise specified)

Parameter	Symbol	Value			Unit	Test Condition
		min.	typ.	max.		

Static Characteristic

Drain-source breakdown voltage	BV _{DSS}	650	-	-	V	V _{GS} =0V, I _D =250uA
Gate threshold voltage	V _{GS(th)}	3	-	4	V	V _{DS} =V _{GS} , I _D =250uA
Zero gate voltage drain current	I _{DSS}	-	-	1	μA	V _{DS} =650V, V _{GS} =0V
		-	10	-		T _C =25°C
Gate-source leakage current	I _{GSS}	-	-	±100	nA	T _C =150°C
Drain-source on-state resistance	R _{DS(on)}	-	81	99	mΩ	V _{GS} =10V, I _D =17A,
		-	205	-		T _C =25°C
Transconductance	g _{fs}	-	29.6	-	S	T _C =150°C
						V _{DS} =20V, I _D =17A

Dynamic Characteristic

Input Capacitance	C _{iSS}	-	2345	-	pF	V _{GS} =0V, V _{DS} =100V, f=1MHz
Output Capacitance	C _{oss}	-	133	-		
Reverse Transfer Capacitance	C _{rSS}	-	43	-		
Gate Total Charge	Q _G	-	70	-	nC	V _{GS} =10V, V _{DS} =480V, I _D =17A
Gate-Source charge	Q _{gs}	-	15.6	-		
Gate-Drain charge	Q _{gd}	-	28	-		
Turn-on delay time	t _{d(on)}	-	36.5	-	ns	T _j =25°C, V _{GS} =10V, I _D =17A, V _{DS} =400V, R _g =27Ω
Rise time	t _r	-	42.5	-		
Turn-off delay time	t _{d(off)}	-	254	-		
Fall time	t _f	-	40	-		
Gate resistance	R _G	-	0.86	-	Ω	V _{GS} =0V, V _{DS} =0V, f=1MHz

Body Diode Characteristic

Parameter	Symbol	Value			Unit	Test Condition
		min.	typ.	max.		
Body Diode Forward Voltage	V_{SD}	0.7	0.86	1.2	V	$V_{GS}=0V, I_{SD}=17A$
Body Diode Reverse Recovery Time	t_{rr}	-	347	-	ns	$I_{sd}=17A$ $dI/dt=100A/us, V_{ds}=400V$
Body Diode Reverse Recovery Charge	Q_{rr}	-	5.92	-	uC	

Typical Performance Characteristics

Fig 1. Output Characteristics (Tj=25°C)

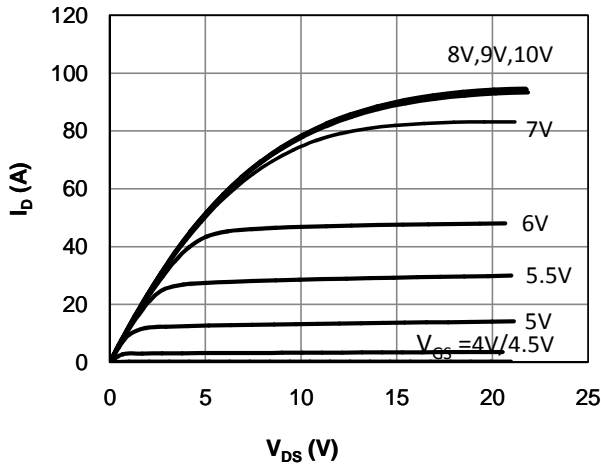

Fig 2. Output Characteristics (Tj=150°C)

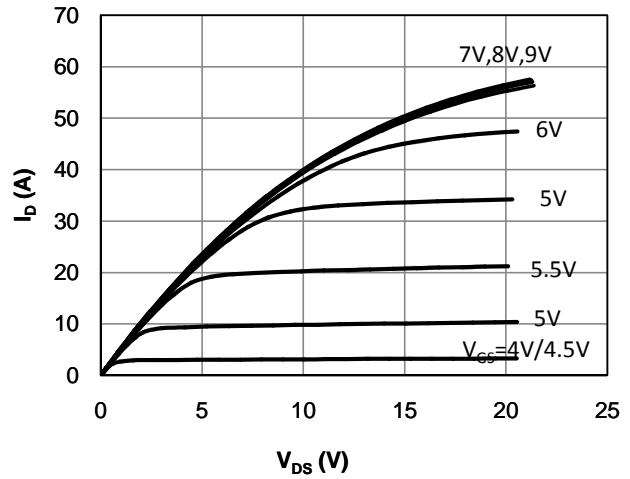

Fig 3: Transfer Characteristics

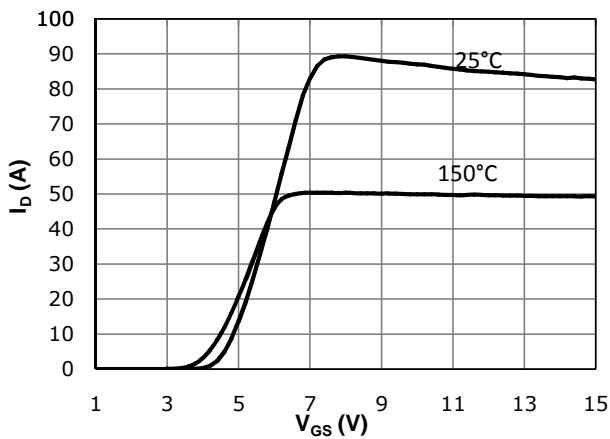

Fig 4: V_{TH} Vs Tj Temperature Characteristics

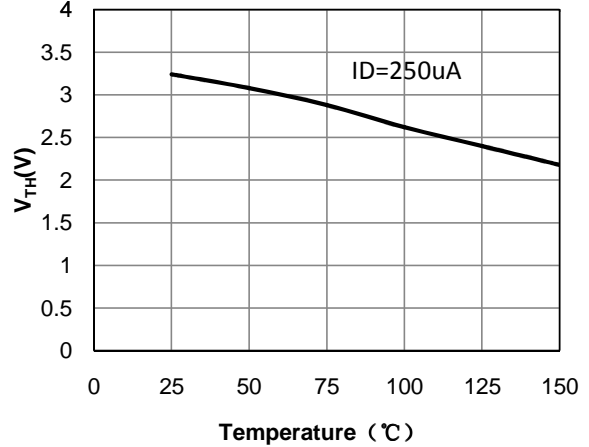

Fig 5: $R_{DS(on)}$ Vs I_{DS} Characteristics ($T_c = 25^\circ\text{C}$)

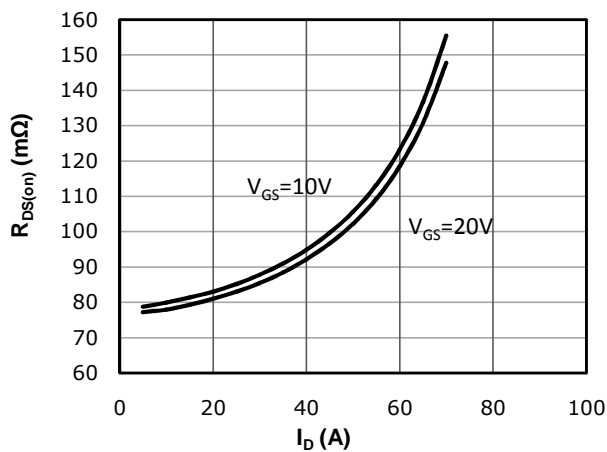

Fig 6: $R_{DS(on)}$ vs. Temperature

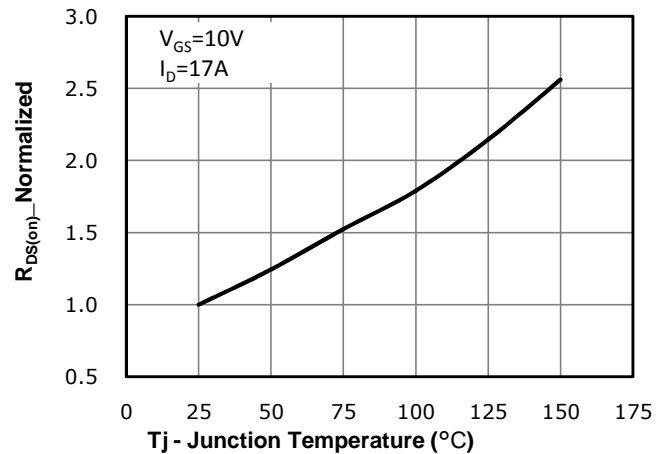

Fig 7: BVDSS vs. Temperature

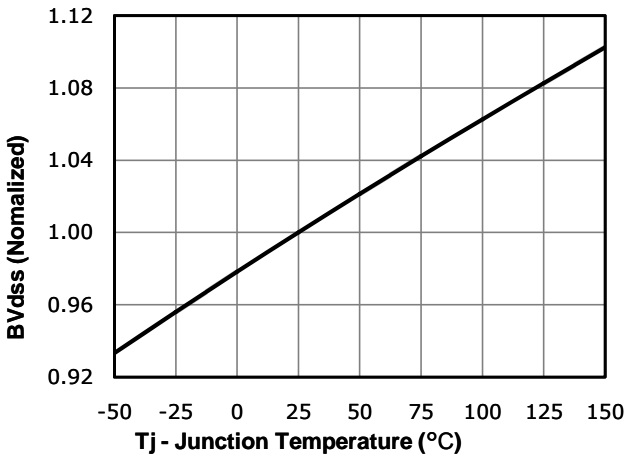

Fig 8: Rds(on) vs Gate Voltage

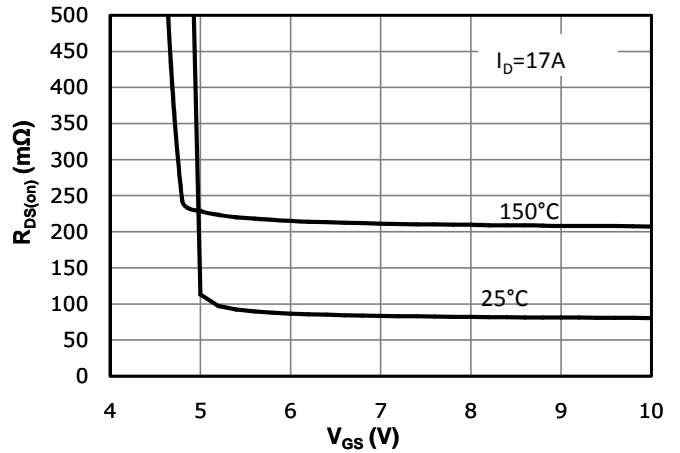

Fig 9: Body-diode Forward Characteristics

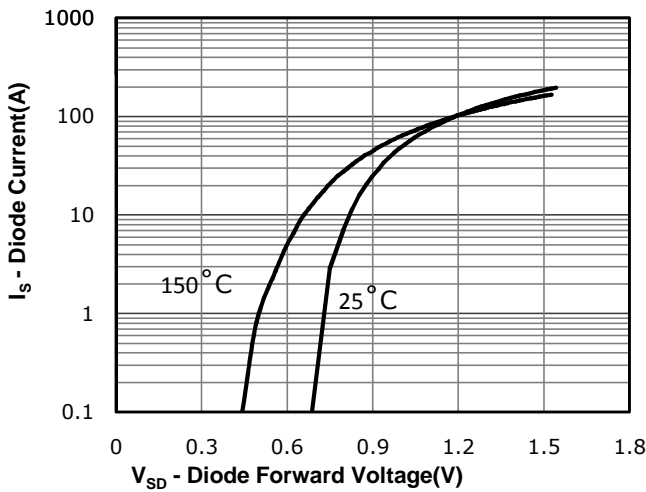

Fig 10: Gate Charge Characteristics

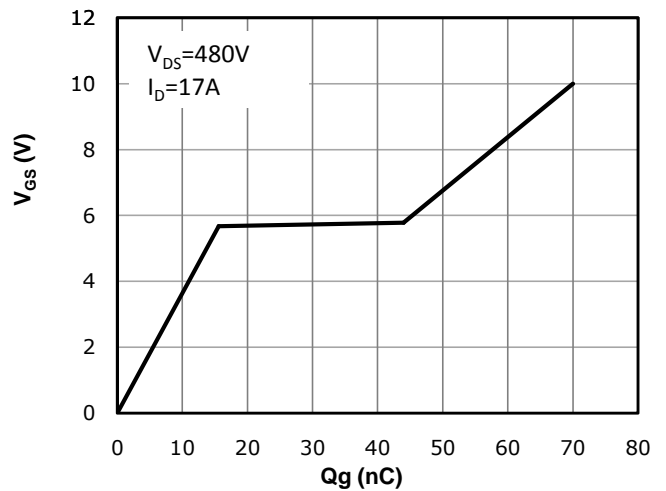

Fig 11: Capacitance Characteristics

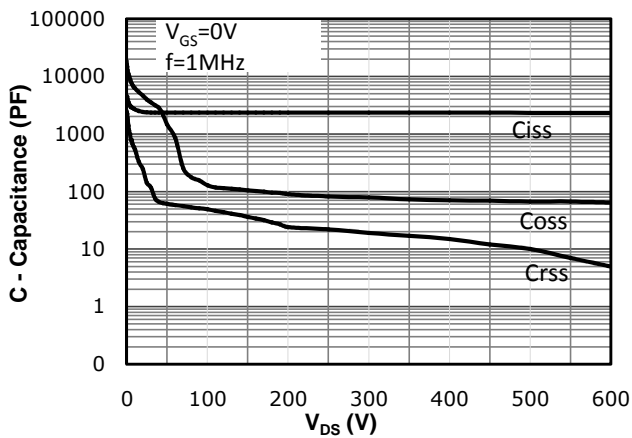

Fig 12: Safe Operating Area

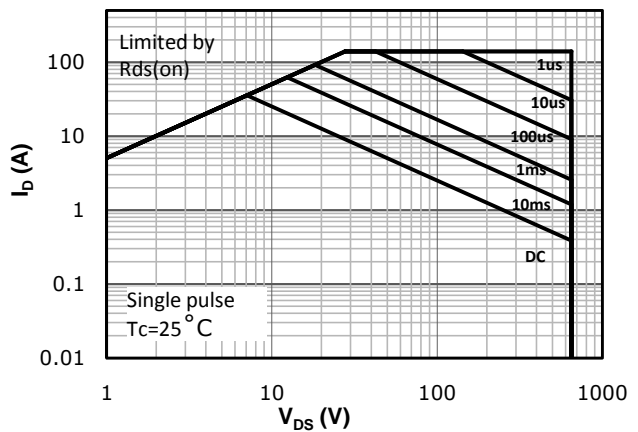
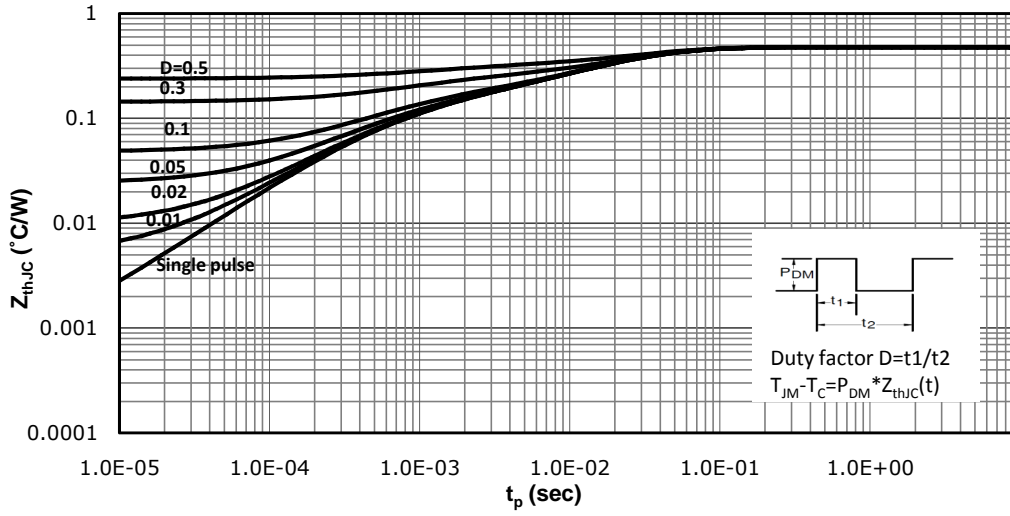
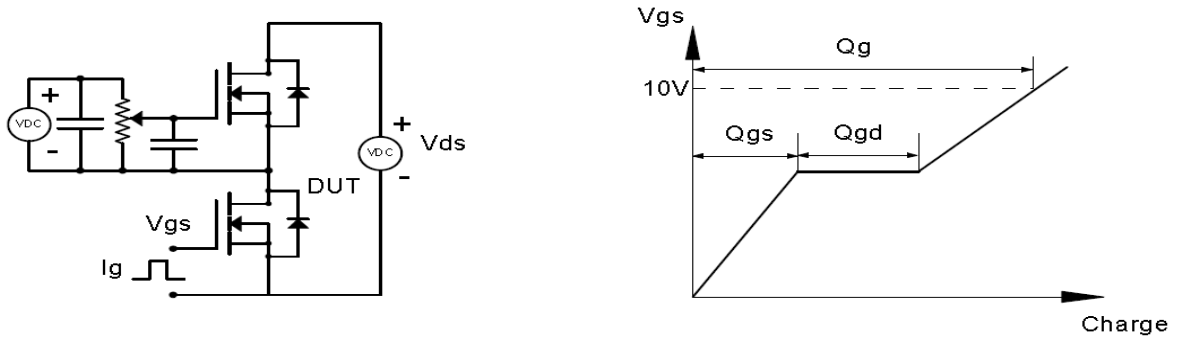

Fig 13: Max. Transient Thermal Impedance



Test Circuit & Waveform

Gate Charge Test Circuit & Waveform



Resistive Switching Test Circuit & Waveforms

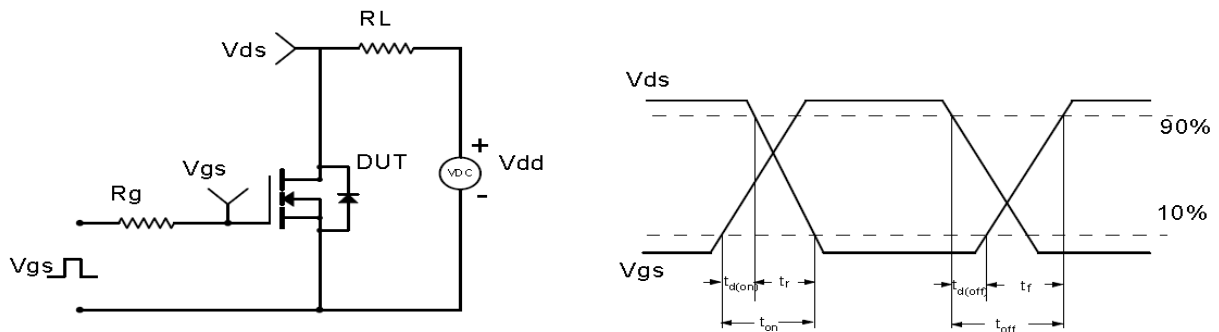

Unclamped Inductive Switching (UIS) Test Circuit & Waveforms

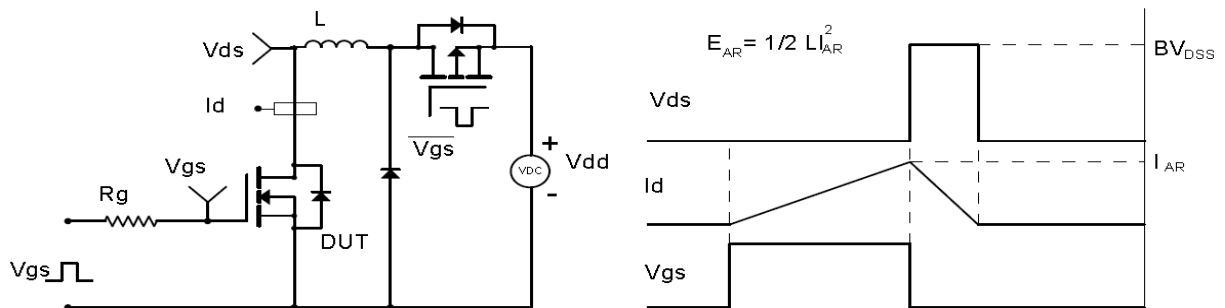

Diode Recovery Test Circuit & Waveforms

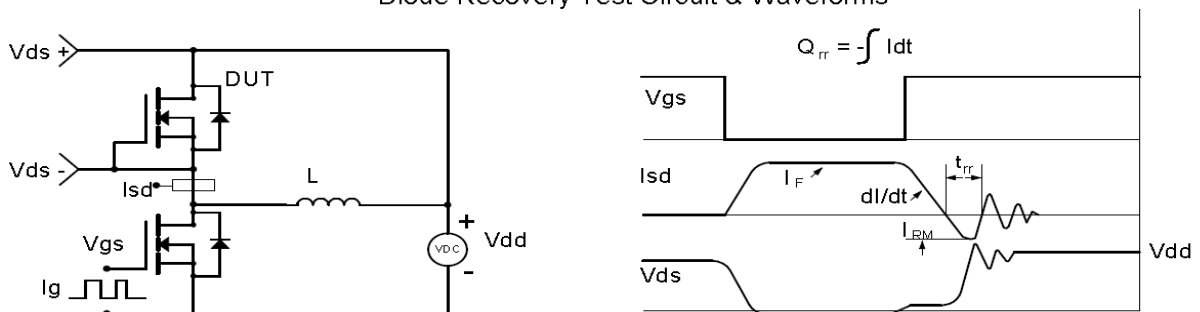

Package Outline: TO-220

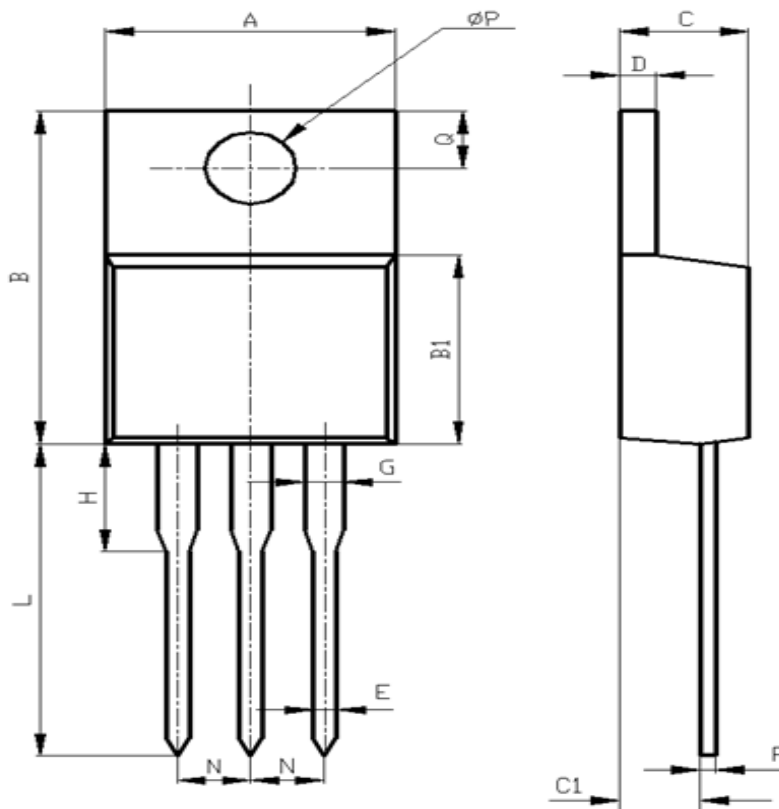

Symbol	Dimensions In Millimeters		Dimensions In Inches	
	Min.	Max.	Min.	Max.
A	9.60	10.60	0.378	0.417
B	15.00	16.00	0.591	0.630
B1	8.90	9.50	0.350	0.374
C	4.30	4.80	0.169	0.189
C1	2.30	3.10	0.091	0.122
D	1.20	1.40	0.047	0.055
E	0.70	0.90	0.028	0.035
F	0.30	0.60	0.012	0.024
G	1.17	1.37	0.046	0.054
H	2.70	3.80	0.106	0.150
L	12.60	14.80	0.496	0.583
N	2.34	2.74	0.092	0.108
Q	2.40	3.00	0.094	0.118
ϕP	3.50	3.90	0.138	0.154

Marking



NOTE:

NXBBAAAAY

X —Assembly location code

BB —Fab code

AAAA —Lot code

Y —Bin code

Revision History

Revision	Date	Major changes
1.0	2020-8-19	First version

Disclaimer

Unless otherwise specified in the datasheet, the product is designed and qualified as a standard commercial product and is not intended for use in applications that require extraordinary levels of quality and reliability, such as automotive, aviation/aerospace and life-support devices or systems.

Any and all semiconductor products have certain probability to fail or malfunction, which may result in personal injury, death or property damage. Customer are solely responsible for providing adequate safe measures when design their systems.

CRM(CQ) reserves the right to improve product design, function and reliability without notice.

X-ON Electronics

Largest Supplier of Electrical and Electronic Components

Click to view similar products for [MOSFET](#) category:

Click to view products by [CRMICRO](#) manufacturer:

Other Similar products are found below :

[IRFD120](#) [JANTX2N5237](#) [2SK2267\(Q\)](#) [BUK455-60A/B](#) [TK100A10N1,S4X\(S](#) [MIC4420CM-TR](#) [VN1206L](#) [NDP4060](#) [SI4482DY](#)
[IRS2092STRPBF-EL](#) [IPS70R2K0CEAKMA1](#) [TK31J60W5,S1VQ\(O](#) [TK31J60W,S1VQ\(O](#) [TK16J60W,S1VQ\(O](#) [2SK2614\(TE16L1,Q\)](#)
[DMN1017UCP3-7](#) [EFC2J004NUZTDG](#) [P85W28HP2F-7071](#) [DMN1053UCP4-7](#) [NTE2384](#) [DMC2700UDMQ-7](#) [DMN2080UCB4-7](#)
[DMN61D9UWQ-13](#) [US6M2GTR](#) [DMN31D5UDJ-7](#) [DMP22D4UFO-7B](#) [IPS60R3K4CEAKMA1](#) [DMN1006UCA6-7](#) [DMN16M9UCA6-7](#)
[STF5N65M6](#) [IRF40H233XTMA1](#) [STU5N65M6](#) [DMN6022SSD-13](#) [DMN13M9UCA6-7](#) [DMTH10H4M6SPS-13](#) [IPS60R360PFD7SAKMA1](#)
[DMN2990UFB-7B](#) [SSM3K35CT,L3F](#) [IPLK60R1K0PFD7ATMA1](#) [2N7002W-G](#) [MCAC30N06Y-TP](#) [IPWS65R035CFD7AXKSA1](#)
[MCQ7328-TP](#) [SSM3J143TU,LXHF](#) [PJMF280N65E1_T0_00201](#) [PJMF380N65E1_T0_00201](#) [PJMF280N60E1_T0_00201](#)
[PJMF600N65E1_T0_00201](#) [PJMF900N65E1_T0_00201](#) [PJMF900N60E1_T0_00201](#)