

1、 General Description

The CS3809EO is an 18W (per channel) efficient, Class-D audio power amplifier for driving bridged-tied stereo speakers. Advanced EMI suppression technology enables the use of inexpensive ferrite bead filters at the outputs while meeting EMC requirements. The DC detect circuit measures the frequency and amplitude of the PWM signal and shuts off the output stage if the input capacitors are damaged or shorts exist on the inputs.

The CS3809EO can drive stereo speakers as low as 4Ω. The high efficiency of the CS3809EO, 92%, eliminates the need for an external heat sink when playing music. The superior headphone noise suppression technology allows the CS3809EO to implement headphone output applications with simple peripherals.

CS3809EO used in televisions and consumer audio equipment.

Features

- Inductor-free applications can be EMC certified with an inexpensive magnetic bead filter
- Excellent headphone noise suppression technology enables headphone output applications with simple peripherals
- 18W/ch into an 8Ω load at 10% THD+N from a 17V supply
- 10W/ch into 4Ω loads at 10% THD+N from a 10V supply
- 30W into a 4Ω mono load at 10% THD+N from a 16V supply
- 92% efficient Class-D operation eliminates need for heat sinks
- Wide supply voltage range allows operation from 8V to 20V
- DC protection
- Robust pin-to-pin short circuit protection and thermal protection with auto recovery
- Excellent THD+N/Pop-free performance
- Differential inputs
- Easy board layout
- Standby
- Package: SOP16-EP

2、Function Diagram and Pin Description

2.1、Function Diagram

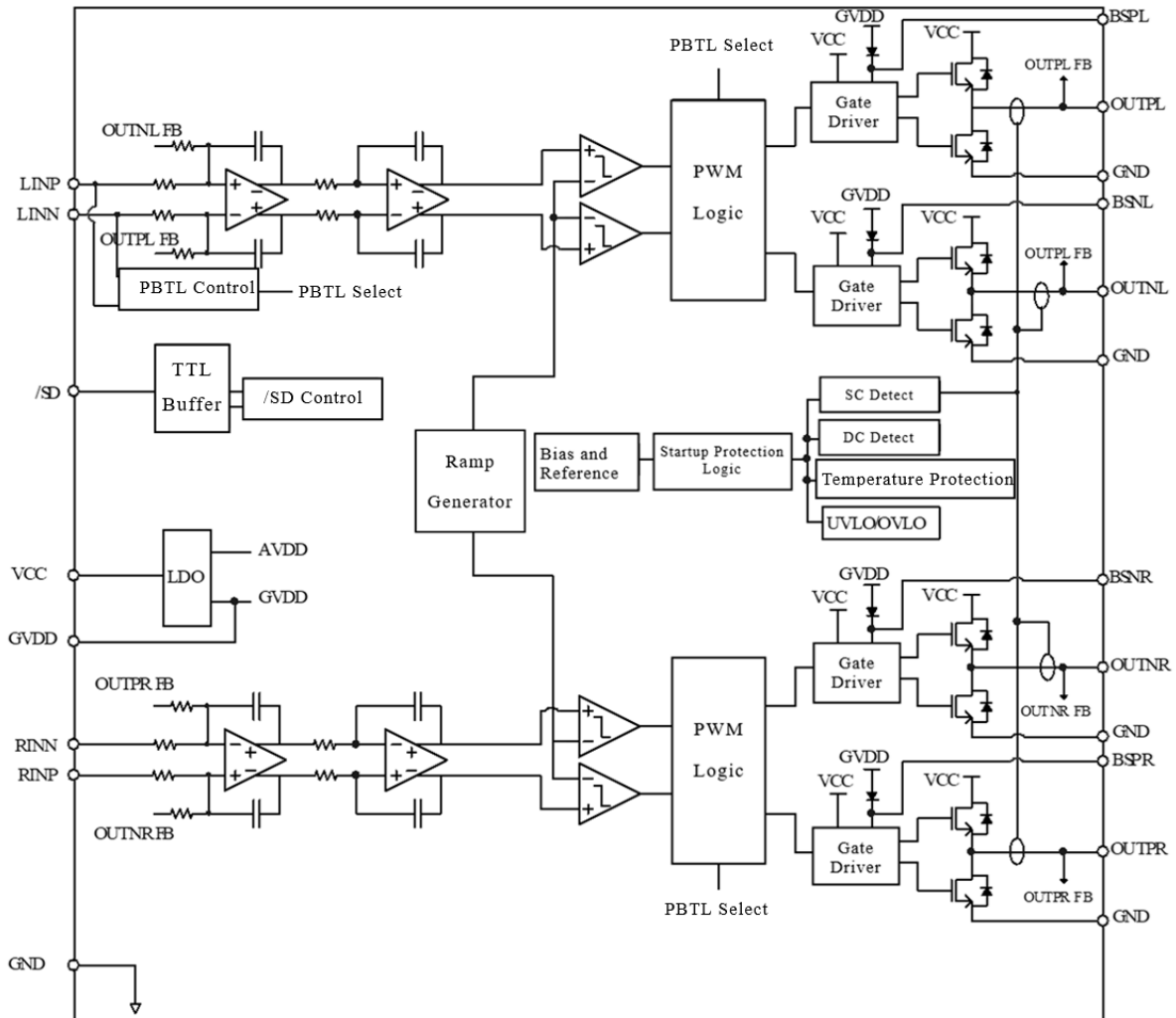

2. 2、 Pin Configuration

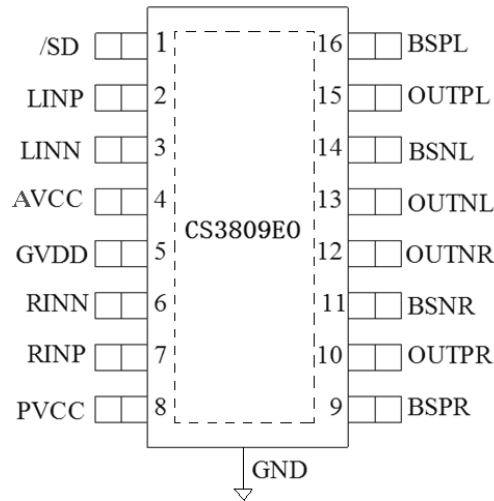

2. 3、 Pin Description

Pin	Symbol	Function	Attribute
1	/SD	Standby Logic Input, Low-level Standby, High-level Work, Needs to be Connected to VCC Through 100kΩ When Connected to the High Level	I
2	LINP	Positive Audio Input for Left Channel	I
3	LINN	Negative Audio Input for Left Channel	I
4	AVCC	Analog Supply	P
5	GVDD	High-side FET Gate Drive Supply Also Should be used as Supply for PLIMIT Function	O
6	RINN	Negative Audio Input for Right Channel	I
7	RINP	Positive Audio Input for Right Channel	I
8	PVCC	Power Supply	P
9	BSPR	Bootstrap for Right Channel, Positive High-side FET	I
10	OUTPR	Class-D H-bridge Positive Output for Right Channel	O
11	BSNR	Bootstrap for Right Channel, Negative High-side FET	I
12	OUTNR	Class-D H-bridge Negative Output for Right Channel	O

To be continued

Continued

Pin	Symbol	Function	Attribute
13	OUTNL	Class-D H-bridge Negative Output for Left Channel	O
14	BSNL	Bootstrap for Left Channel, Negative High-side FET	I
15	OUTPL	Class-D H-bridge Positive Output for Left Channel	O
16	BSPL	Bootstrap for Left Channel, Positive High-side FET	I
Bottom Pad	GND	Bottom Heatsink, GND	GND

3、Electrical Characteristics

3.1、Absolute Maximum Ratings

Unless otherwise specified, $T_{amb}=25^{\circ}\text{C}$

Parameter		Symbol	Value	Unit
Supply Voltage		V_{CC}	-0.3~20	V
Interface Pin Voltage	/SD	V_{IN}	-0.3~ $V_{CC}+0.3$	V
	RINN, RINP, LINN, LINP		-0.3~5.3	
Operating Free-air Temperature Range		T_{amb}	-40~85	$^{\circ}\text{C}$
Storage Temperature Range		T_{stg}	-65~150	$^{\circ}\text{C}$
Load Resistance		R	> 3.2	Ω

3.2、Recommended Operating Conditions

Parameter	Symbol	Test Conditions	Limit		Unit
			Min	Max	
Supply Voltage	V_{CC}	V_{CC}	8	20	V
High-level Input Voltage	V_{IH}	/SD	2	-	V
Low-level Input Voltage	V_{IL}	/SD	-	0.8	V
High-level Input Current	I_{IH}	/SD, $V_I=2\text{V}$, $V_{CC}=18\text{V}$	-	50	μA
Low-level Input Current	I_{IL}	/SD, $V_I=0.8\text{V}$, $V_{CC}=18\text{V}$	-	5	μA
Operating Temperature	T_{amb}	-	-40	85	$^{\circ}\text{C}$

3. 3、Electrical Characteristics

3. 3. 1、DC Characteristics

Unless otherwise specified, $T_A=25^{\circ}\text{C}$, $V_{CC}=18\text{V}$, $R_L=8\Omega$

Parameter	Symbol	Test Conditions	Value			Unit	
			Min	Typ	Max		
Output Offset Voltage	$ V_{OS} $	$V_I=0\text{V}$	-	1.5	15	mV	
Gate Drive Supply	GVDD	$I_{GVDD}=100\mu\text{A}$	5.0	6.2	6.8	V	
Quiescent Supply Current	I_{CC}	/SD=2V, No Load PVCC=18V	-	40	70	mA	
Quiescent Supply Current in Shutdown Mode	$I_{CC(SD)}$	/SD=0.8V, No Load PVCC=18V	-	250	400	μA	
Drain-source On-state Resistance	$r_{DS(ON)}$	$V_{CC}=12\text{V}$ $I_o=500\text{mA}$ $T_J=25^{\circ}\text{C}$	High Side	-	240	-	$\text{m}\Omega$
			Low Side	-	240	-	$\text{m}\Omega$
			Total Resistor	-	480	-	$\text{m}\Omega$
Gain	G	-	24	26	28	dB	
Turn-on Time	t_{ON}	/SD=2V	-	50	-	ms	
Turn-off Time	t_{OFF}	/SD=0.8V	-	2	-	μs	
DC Detect Time	t_{DCDET}	$V_{(RINN)}=6\text{V}$, $V_{(RINP)}=0\text{V}$	-	420	-	ms	

Unless otherwise noted, $T_A=25^{\circ}\text{C}$, $V_{CC}=12\text{V}$, $R_L=8\Omega$

Parameter	Symbol	Test Conditions	Value			Unit	
			Min	Typ	Max		
Output Offset Voltage	$ V_{OS} $	$V_I=0\text{V}$	-	1.5	15	mV	
Quiescent Supply Current	I_{CC}	/SD=2V, No Load PVCC=12V	-	25	50	mA	
Quiescent Supply Current in Shutdown Mode	$I_{CC(SD)}$	/SD=0.8V, No Load PVCC=12V	-	200	-	μA	
Drain-source On-state Resistance	$r_{DS(ON)}$	$V_{CC}=12\text{V}$ $I_o=500\text{mA}$ $T_J=25^{\circ}\text{C}$	High Side	-	240	-	$\text{m}\Omega$
			Low Side	-	240	-	$\text{m}\Omega$
			Total Resistor	-	480	-	$\text{m}\Omega$
Gain	G	-	25	26	27	dB	
Turn-on Time	t_{ON}	/SD=2V	-	50	-	ms	
Turn-off Time	t_{OFF}	/SD=0.8V	-	2	-	μs	
Gate Drive Supply	GVDD	$I_{GVDD}=2\text{mA}$	5.0	6.2	6.8	V	

3.3.2、AC Characteristics

Unless otherwise noted, $T_A=25^{\circ}\text{C}$, $V_{CC}=18\text{V}$, $R_L=8\Omega$

Parameter	Symbol	Test Conditions	Value			Unit
			Min	Typ	Max	
Power Supply Ripple Rejection	k_{SVR}	1kHz, 200m V_{PP} Ripple Input AC-coupled to AGND	-	-70	-	dB
Continuous Output Power	P_O	THD+N=10%, f=1kHz $V_{CC}=16\text{V}$	-	15	-	W
Total Harmonic Distortion Plus Noise	THD+N	$V_{CC}=16\text{V}$ f=1kHz $P_O=7.5\text{W}$ (Half-power)	-	0.1	-	%
Output Integrated Noise	V_N	20Hz~22kHz, A-weighted Filter	-	65	-	μV
			-	-80	-	dBV
Crosstalk	CT	$V_O=1\text{V}_{rms}$, Gain=20dB f=1kHz	-	-100	-	dB
Signal-to-noise Ratio	SNR	Maximum Output at THD+N<1%, f=1kHz Gain=20dB	-	102	-	dB
Oscillator Frequency	f_{osc}	-	200	-	450	kHz
Thermal Trip Point	-	-	-	150	-	$^{\circ}\text{C}$
Thermal Hysteresis	-	-	-	20	-	$^{\circ}\text{C}$

Unless otherwise noted, $T_A=25^{\circ}\text{C}$, $V_{CC}=12\text{V}$, $R_L=8\Omega$

Parameter	Symbol	Test Conditions	Value			Unit
			Min	Typ	Max	
Power Supply Ripple Rejection	k_{SVR}	20Hz~1kHz 200m V_{PP} Ripple, Gain=20dB Input AC-coupled to AGND	-	-70	-	dB
Continuous Output Power	P_O	THD+N=10%, f=1kHz $V_{CC}=13\text{V}$	-	10	-	W
Total Harmonic Distortion Plus Noise	THD+N	$R_L=8\Omega$ f=1kHz $P_O=5\text{W}$ (Half-power)	-	0.06	-	%
Output Integrated Noise	V_N	20Hz~22kHz, A-weighted Filter, Gain=20dB	-	65	-	μV
			-	-80	-	dBV
Crosstalk	-	$P_O=1\text{W}$, Gain=20dB f=1kHz	-	-100	-	dB
Signal-to-noise Ratio	SNR	Maximum Output at THD+N<1%, f=1kHz Gain=20dB	-	102	-	dB
Oscillator Frequency	f_{osc}	-	200	-	450	kHz
Thermal Trip Point	-	-	-	150	-	$^{\circ}\text{C}$
Thermal Hysteresis	-	-	-	20	-	$^{\circ}\text{C}$

4、Typical Application Circuit and Information

4. 1、Application Circuit

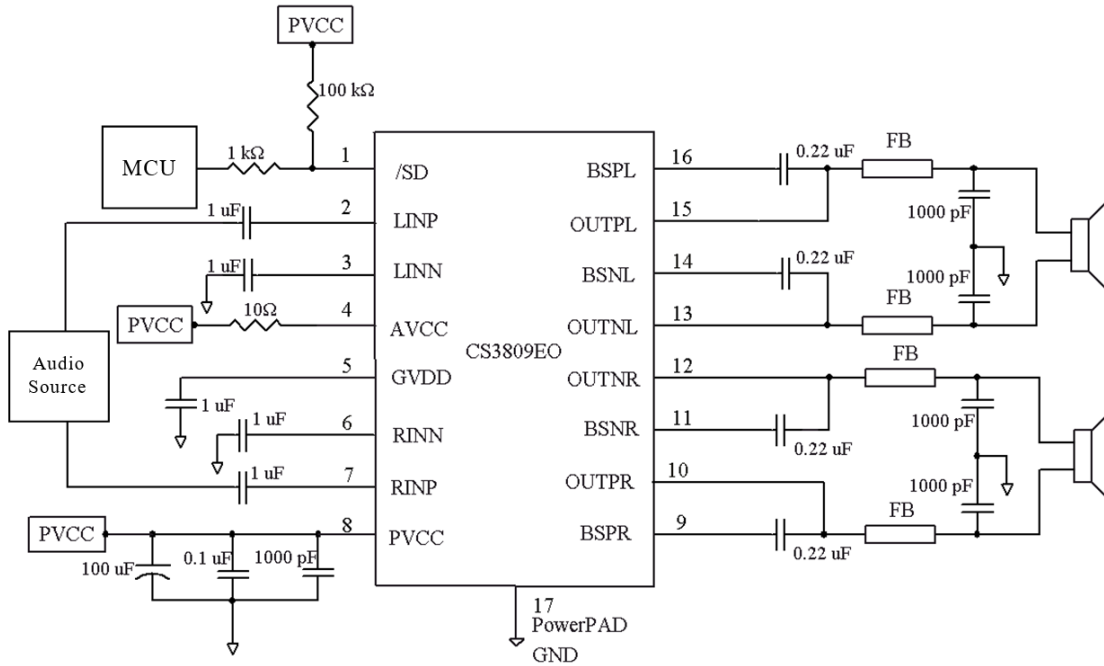

Stereo Class-D amplifier with BTL output and single-ended inputs

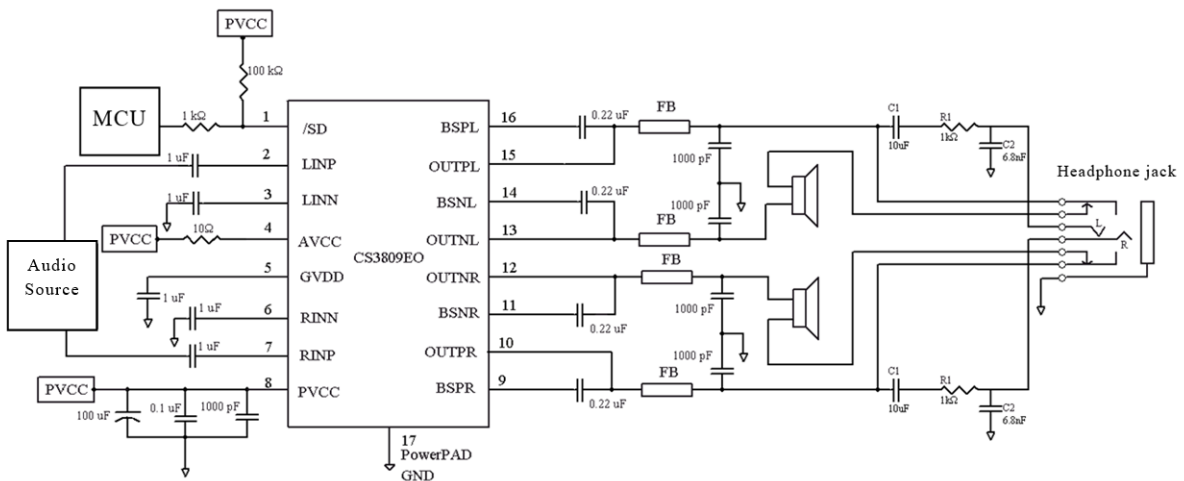

Single-ended input with headphone driver, BTL output Class-D amplifier

- Headphone Driver Application Notes

1) CS3809EO add a simple peripheral line to the output port, and it can be used as a stereo headphone driver. Refer to the above typical application lines to build peripherals, and stereo headphone drivers can be realized. When the earphone jack is suspended, the speaker plays normally; when the earphones are plugged in, the signal at the speaker end is disengaged, and the L and R ports of the earphones are connected to the filtered audio signal. CS3809EO excellent headphone noise suppression technology, so that the use of simple peripherals can meet the requirements of headphone applications;

2) The parameters of the earphone signal filter are as follows: $C=10\mu\text{F}$, $R=1\text{k}\Omega$, $C=6.8\text{nF}$.

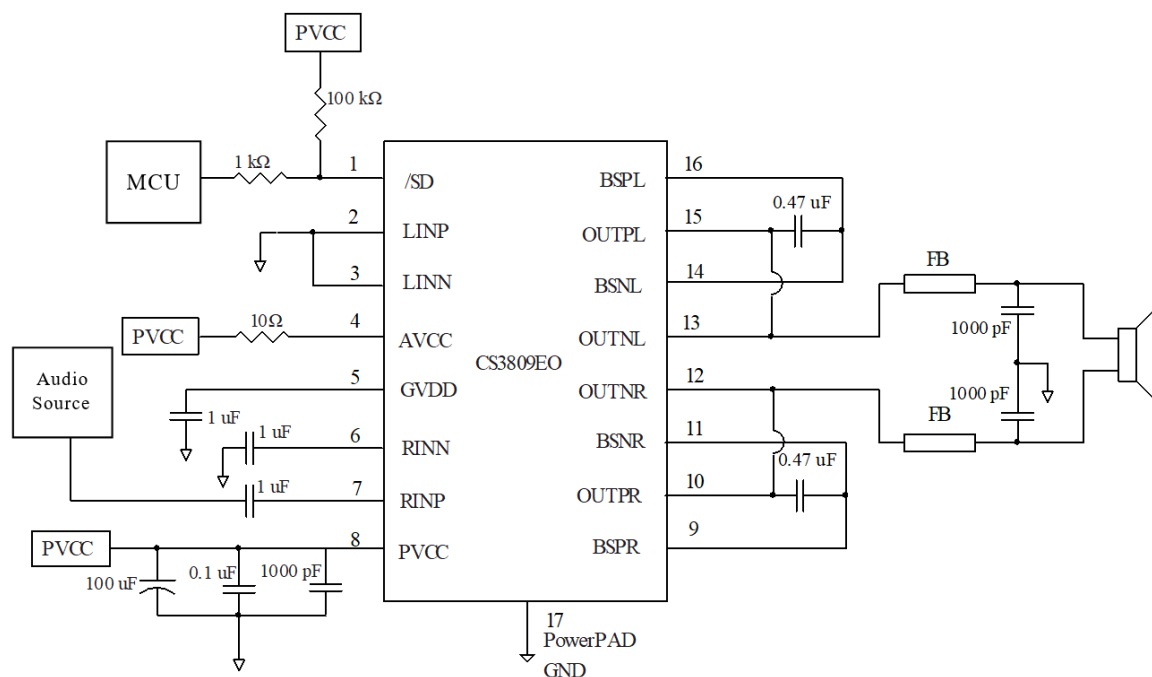

Stereo Class-D amplifier with PBTL output and single-ended input

- PBTL Mode Application Notes

CS3809EO support for PBTL mode applications. If the LAMP pin and LAMP pin are set low at the same time, the positive and negative outputs of each channel (left and right channels) are synchronized. In PBTL mode, the input signal needs to be added to the right input and the speaker is connected between the left and right outputs.

4. 2、 Applications Information

- /SD Operation

The input port of /SD should be at high potential when the power amplifier is working normally, and the output of /SD will be turned off when it is pulled to low potential, and the circuit will enter standby mode. Can't leave the /SD dangling and disconnected, because this will make the power amplifier appear unpredictable state.

For the best power-off pop performance, place the amplifier in the shutdown mode prior to removing the power supply voltage.

- DC Detect

The CS3809EO has circuitry which will protect the speakers from DC current which might occur due to defective capacitors on the input or shorts on the printed circuit board at the inputs.

To avoid nuisance faults due to the DC detect circuit, hold the SD pin low at power-up until the signals at the inputs are stable.

- Short-Circuit Protection and Automatic Recovery Feature

CS3809EO has protection from over current conditions caused by a short circuit on the output stage. CS3809EO can automatic recovery from the short circuit protection.

- Thermal Protection

Thermal protection on the CS3809EO prevents damage to the device when the internal die temperature exceeds 150°C. There is a $\pm 15^\circ\text{C}$ tolerance on this trip point from device to device. Once the die temperature exceeds the thermal set point, the device enters into the shutdown state and the outputs are disabled. This is not a latched fault. The thermal fault is cleared once the temperature of the die is reduced by 20°C. The device begins normal operation at this point with no external system interaction.

5、Characteristics Curve

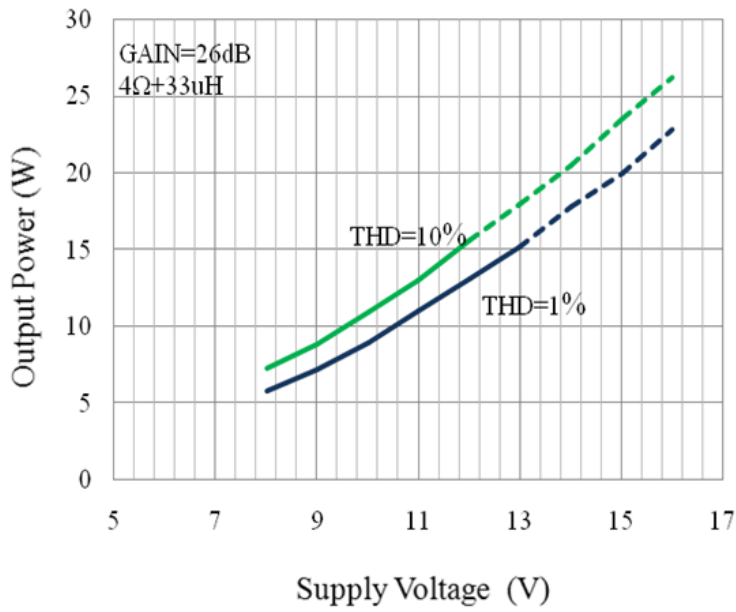

Output Power vs Supply Voltage

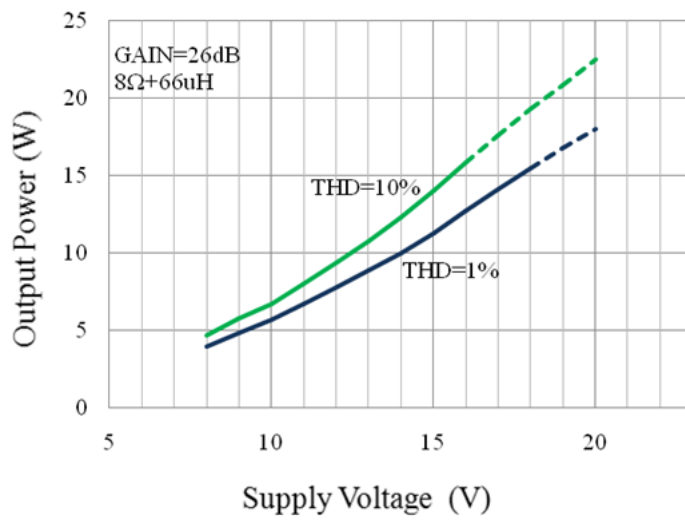

Output Power vs Supply Voltage

6、 Package Dimensions (Unit: mm)

6. 1、 Package Outline

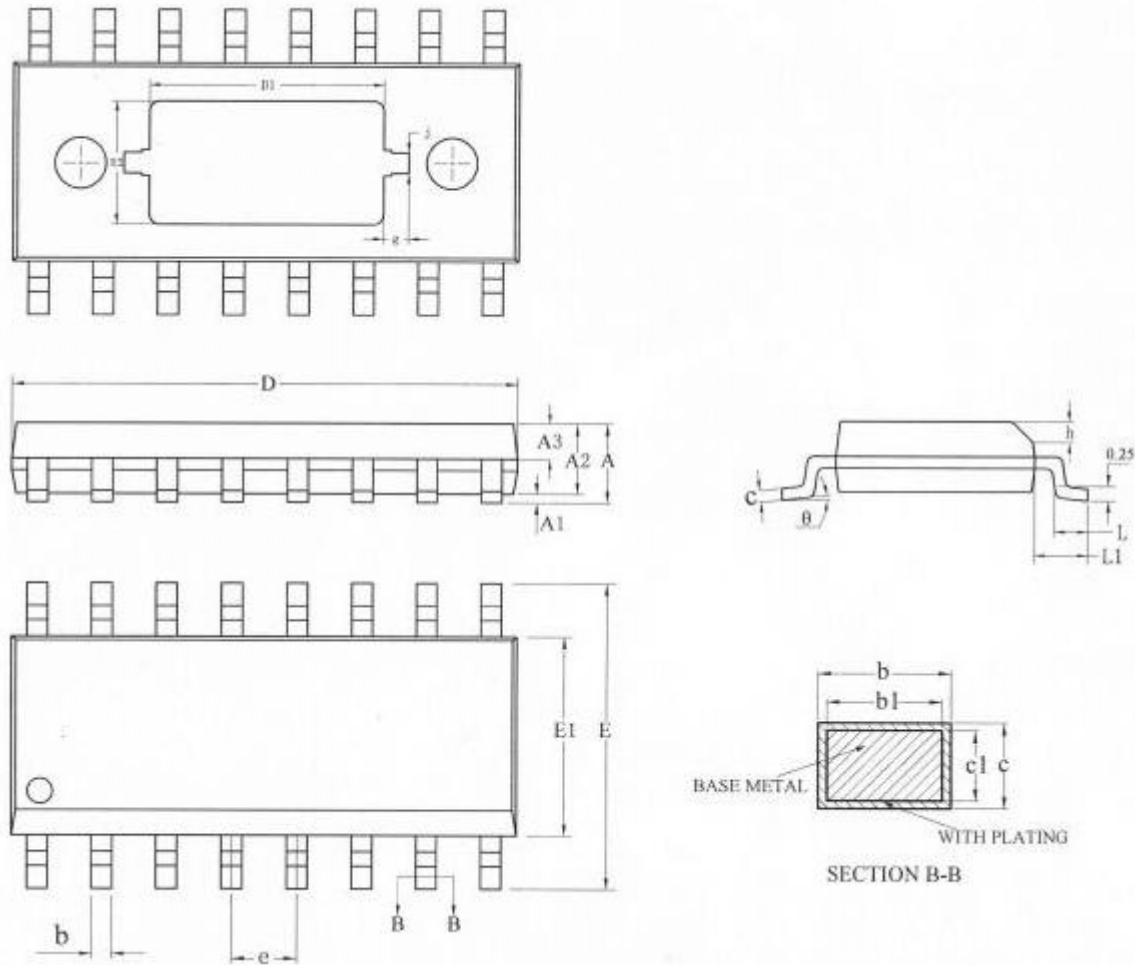

6. 2、 Mechanical Data

Symbol	Min.	Nom.	Max.	Symbol	Min.	Nom.	Max.
A	-	-	1.75	E1	3.70	3.90	4.10
A1	0.05	-	0.15	e	1.27BSC		
A2	1.30	1.40	1.50	E2	-	2.41	-
A3	0.60	0.65	0.70	D1	-	4.57	-
b	0.39	-	0.48	g	-	0.508	-
b1	0.38	0.41	0.43	j	-	0.40	-
c	0.21	-	0.26	h	0.25	-	0.50
c1	0.19	0.20	0.21	L	0.50	-	0.80
D	9.70	9.90	10.10	L1	1.05BSC		
E	5.80	6.00	6.20	θ	0	-	8°

CRM ICBG (wuxi) Co., Ltd.

Headquarters address: 180-6 Linghu Avenue, Wuxi, Jiangsu, CHINA. Tel: 0510-85810118

The Branch Address of Shanghai: No. 12, Lane 299, Wenshui Road, Shibei Zhihuiyuan, Jing'an District, Shanghai. Tel: 021-60738989

The Branch Address of Shenzhen: T2 Building ,29/F, Qianhai Life Insurance Financial Center, No. 1100, Xingye Road, Baoan District, Shenzhen City, Guangdong Province Tel: 0755-33088860

Note:

Please read the following information carefully before using CRM's products. And please often contact the relevant departments of CRM to obtain the latest information, because CRM's products are constantly updated and improved. The information in this document is subject to change without notice.

This information is for reference only, and CRM will not be responsible for any losses arising therefrom. CRM does not assume any responsibility for any infringement of third party patents or other rights caused during use.

CRM ICBG (WUXI) CO., LTD. has the right to make corrections, enhancements, improvements, and other changes to its semiconductor products, services and to discontinue any product or service. Buyers should obtain the latest relevant information before placing orders and verifying that such information is up-to-date and complete. All semiconductor products (also referred to herein as "components") are sold subject to CRM ICBG (WUXI) CO., LTD.'s terms, and conditions of sale supplied at the time of order acknowledgment.

CRM ICBG (WUXI) CO., LTD. guarantees that the performance of its components to the specifications applicable at the time of sale, by the warranty in CRM ICBG (WUXI) CO., LTD.'s terms and conditions of sale of semiconductor products. Testing and other quality control techniques are used to the extent CRM ICBG (WUXI) CO., LTD. deems necessary to support this warranty. Except that mandated by applicable law, testing of all parameters of each component is not necessary.

CRM ICBG (WUXI) CO., LTD. assumes no obligation for application assistance or the design of buyers' products. Buyers shall be responsible for their products and applications using CRM ICBG (WUXI) CO., LTD. components. To minimize the risks associated with buyers' products and applications, Buyers should provide adequate design and operational safeguard.

The products of CRM ICBG (WUXI) CO., LTD. have not obtained the licenses for using in FDA Class III (or similar life-critical medical equipment) unless authorized officers of all parties have come to a particular agreement specially on governing the use in this class. Only those CRM ICBG (WUXI) CO., LTD. components which CRM ICBG (WUXI) CO., LTD. has specifically designated as military-grade or "enhanced plastic" are designed and intended for use in military/aerospace applications or environments. Buyers acknowledge and agree that any military or aerospace use of CRM ICBG (WUXI) CO., LTD. components that have not been so designated is solely at the Buyer's risk, and Buyer is solely responsible for compliance with all legal and regulatory requirements in connection with such use.

Unless CRM ICBG (WUXI) CO., LTD. has specifically designated certain components which meet IATF16949 requirements, mainly for automotive use, CRM ICBG (WUXI) CO., LTD. will not be responsible for any failure of such components to meet such requirements.

X-ON Electronics

Largest Supplier of Electrical and Electronic Components

Click to view similar products for [Audio Amplifiers](#) category:

Click to view products by [CRMICRO](#) manufacturer:

Other Similar products are found below :

[LV47002P-E](#) [NCP2890AFCT2G](#) [NTE1192](#) [LC706200CM](#) [IS31AP4915A-QFLS2-TR](#) [TDA1591T](#) [TS2012EIJT](#) [NCP2809BMUTXG](#)
[NJW1157BFC2](#) [IS31AP4996-GRLS2-TR](#) [NCP2823BFCT1G](#) [BD88420GUL-E2](#) [LA4450L-E](#) [IS31AP2036A-CLS2-TR](#) [NTE1110](#) [NTE7100](#)
[NTE7114](#) [NTE7163](#) [NTE7168](#) [NTE7177](#) [NTE7178](#) [NTE7186](#) [NTE7198](#) [NTE7202](#) [NTE7217](#) [BD88400GUL-E2](#) [BD88200GUL-E2](#)
[SABRE9601K](#) [THAT1646W16-U](#) [PAM8965ZLA40-13](#) [TSDP10XX1NLGXZBX](#) [TSDP11XX1NKGIZBX](#) [TSDP11XX1NLGXZBX](#)
[TSDP10XX1NKGIZBX](#) [NJM4580CV-TE1](#) [NJU7084R-TE1](#) [OPA1655DR](#) [LV4910T-MPB-E](#) [NCP2890AFCT2](#) [NCV2211DR2G](#)
[SCY99091FCT2G](#) [TAS5720MRSMR](#) [AW87389FCR](#) [AW8737AFCR](#) [TDA2005R](#) [TDA2030](#) [TDA7265L-J11-A-T](#) [CD2050CZ](#)
[AW88261FCR](#) [TDA7377-JSM](#)