

Product Description

The CT511 Series is an integrated magnetic sensor especially designed for consumer switching applications based on Crocus Technology's patented Magnetic Logic Unit (MLU) technology with integrated CMOS process. The CT511 Series operates with low power consumption in low magnetic fields and large air gaps with industry leading high frequency performance. The open drain output can interface with a system voltage up to 6V for added design flexibility.

The CT511 Series provides high sensitivity in a small footprint SOT-23 package and is cost competitive for high volume manufacturing. Custom solutions are available.



Features and Benefits

- High sensitivity
- Stable temperature performance
- Resistant to mechanical stress
- Low power
- High frequency performance
- Open Drain
- Cost-effective
- RoHS Compliant

Application Examples

- Door or lid closure detection
- Smart phones, tablets, and laptops
- Reed switch replacement
- Motor controllers
- Proximity detection
- Power switch or open-close detection
- Water, electric, and gas utility meters
- Fluid level detection

Table 1: Absolute Maximum Ratings

Parameter	Symbol	Min	Max	Unit
Supply Voltage	Vcc		7	V
Supply Current	Idd		15	mA
Operating Temp	Ta	-40	85	°C
Storage Temp	Ts		150	°C
Soldering Temp	T		260	°C
Magnetic Flux Density	B		1	T
ESD Level (HBM)	Vesd		4,000	V

Table 2: Electrical Characteristics for CT511VA Series

Supply Voltage = 3.0V, System Voltage (V_{sys}) up to 6V, Ta = 25C unless otherwise specified.

Characteristic	Symbol	Min	Typ	Max	Unit
Operating Temperature		-40	25	85	°C
Supply Voltage	Vcc	2.7	3.0	3.3	V
Output Voltage High	V _{SYSH}		0.7V _{sys}		V
Output Voltage Low	V _{SYSL}		0.3V _{sys}		V
Active Mode Current	I _{on}			80	uA
Sleep Mode Current	I _{stb}			170	nA
Average Current	I _{avg}		300		nA
Switching Frequency	F _{sw}		20		Hz
Awake Mode Time	T _{aw}		80		uS
Standby Mode Time	T _{stb}		43		mS
Duty Cycle	DC		0.2		%

Table 3: Electrical Characteristics for CT511VB Series

Supply Voltage = 3.0V, System Voltage (V_{SYS}) up to 6V, $T_a = 25^\circ\text{C}$ unless otherwise specified.

Characteristic	Symbol	Min	Typ	Max	Unit
Operating Temperature		-40	25	85	$^\circ\text{C}$
Supply Voltage	Vcc	2.7	3.0	3.3	V
Output Voltage High	V_{SYSH}		0.7V _{sys}		V
Output Voltage Low	V_{SYSL}		0.3V _{sys}		V
Active Mode Current	I _{on}			80	μA
Sleep Mode Current	I _{stb}			170	nA
Average Current	I _{avg}		2		μA
Switching Frequency	F _{sw}		300		Hz
Awake Mode Time	T _{aw}		80		μs
Standby Mode Time	T _{stb}		3.5		mS
Duty Cycle	DC		2.2		%

Table 4: Electrical Characteristics for CT511VC Series

Supply Voltage = 3.0V, System Voltage (V_{SYS}) up to 6V, $T_a = 25^\circ\text{C}$ unless otherwise specified.

Characteristic	Symbol	Min	Typ	Max	Unit
Operating Temperature		-40	25	85	$^\circ\text{C}$
Supply Voltage	Vcc	2.7	3.0	3.3	V
Output Voltage High	V_{SYSH}		0.7V _{sys}		V
Output Voltage Low	V_{SYSL}		0.3V _{sys}		V
Active Mode Current	I _{on}			80	μA
Sleep Mode Current	I _{stb}			170	nA
Average Current	I _{avg}		20		μA
Switching Frequency	F _{sw}		1.5		KHz
Awake Mode Time	T _{aw}		80		μs
Standby Mode Time	T _{stb}		240		μs
Duty Cycle	DC		25		%

Table 5: Magnetic Characteristics

Supply Voltage = 3.0V

Characteristic	Symbol	Conditions	Min	Typ	Max	Unit
Operate Point	B_{OP}	$T_a = -40C$ to $85C$		25		Gauss
Release point	B_{RP}	$T_a = -40C$ to $85C$		15		Gauss
Hysteresis	B_{HYS}	$B_{OP} - B_{RP}$, $T_a = -40C$ to $85C$		10		Gauss

Figure 1: Magnetic Flux

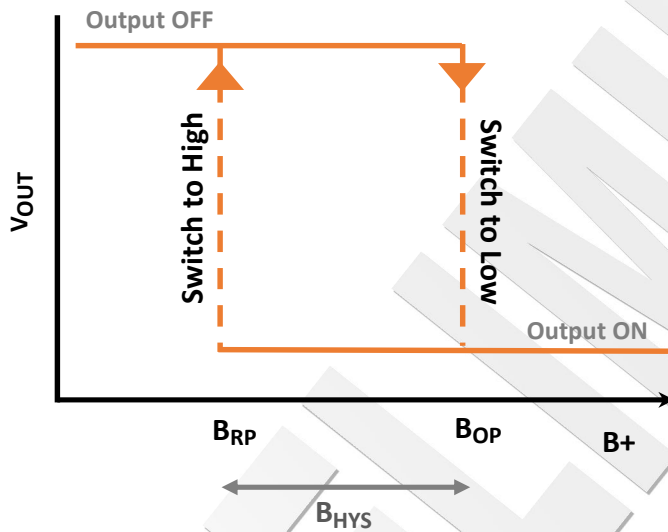

Table 6: Output Behavior versus Magnetic Field

Characteristic	Conditions	Output
South Pole	$B > B_{OP}$	Low
Null or weak magnetic field	$B < B_{RP}$	High
North Pole	$B > B_{OP}$	High

Figure 2: CT512 Series Digital Functional Block Diagram

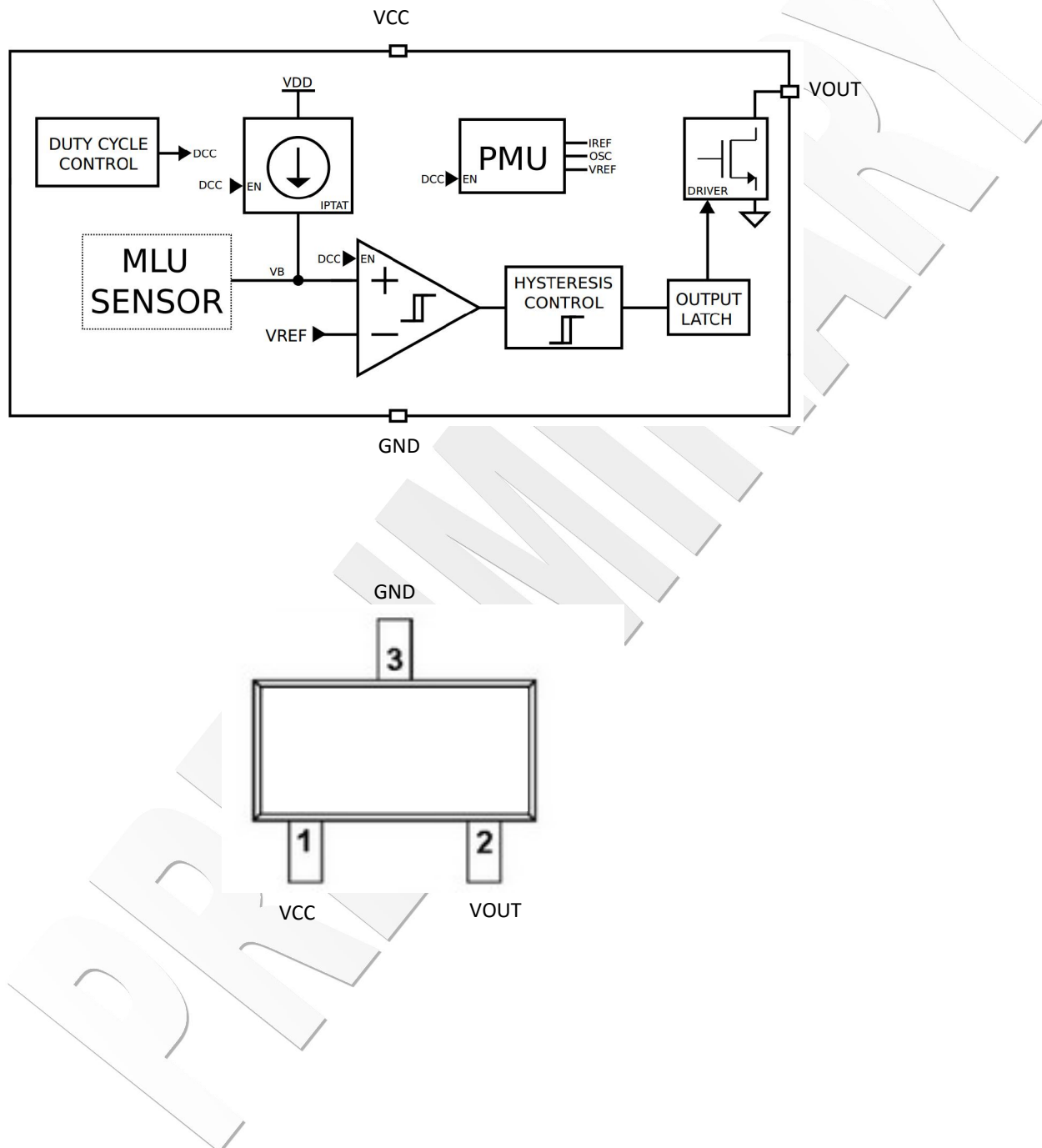

Figure 3: Application Circuit

With the open drain output, the system voltage can range up to 6V. Please keep in mind the supply to the CT511 must remain at 3V. A decoupling capacitor between the supply voltage and ground is recommended with placement close to the magnetic sensor. A typical capacitor value of 0.1 uF will suffice.

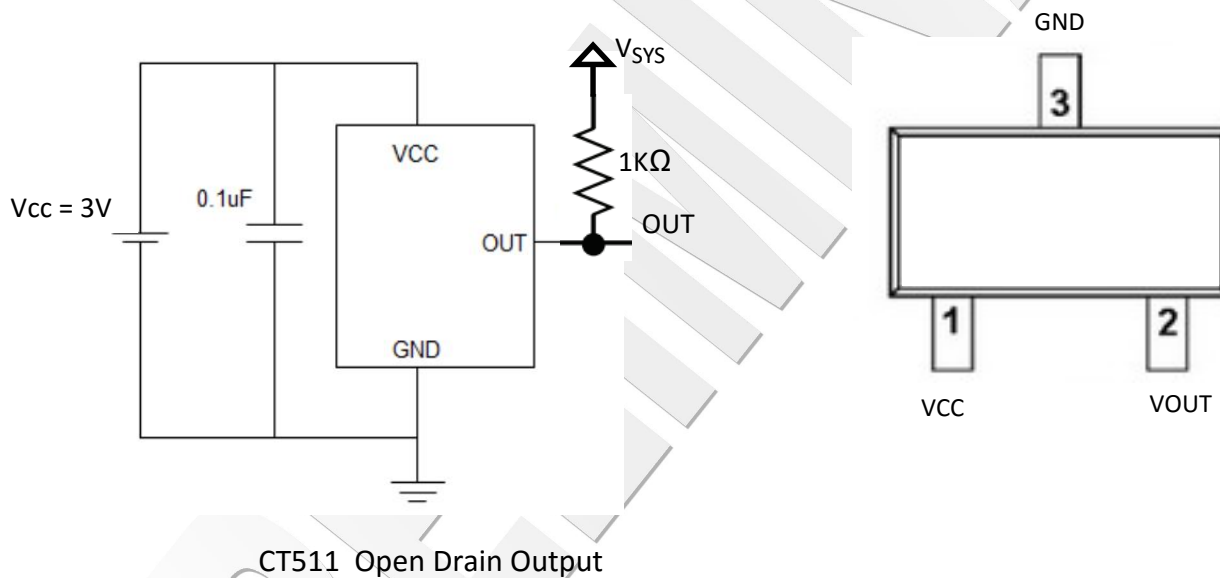
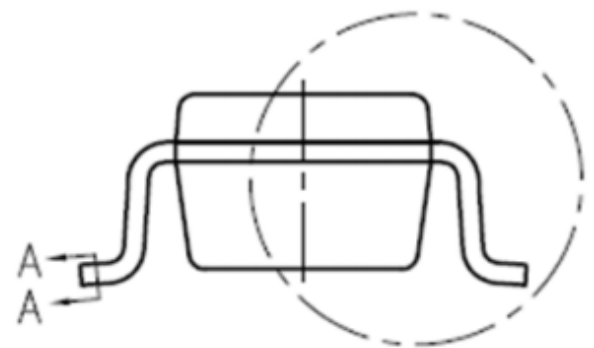
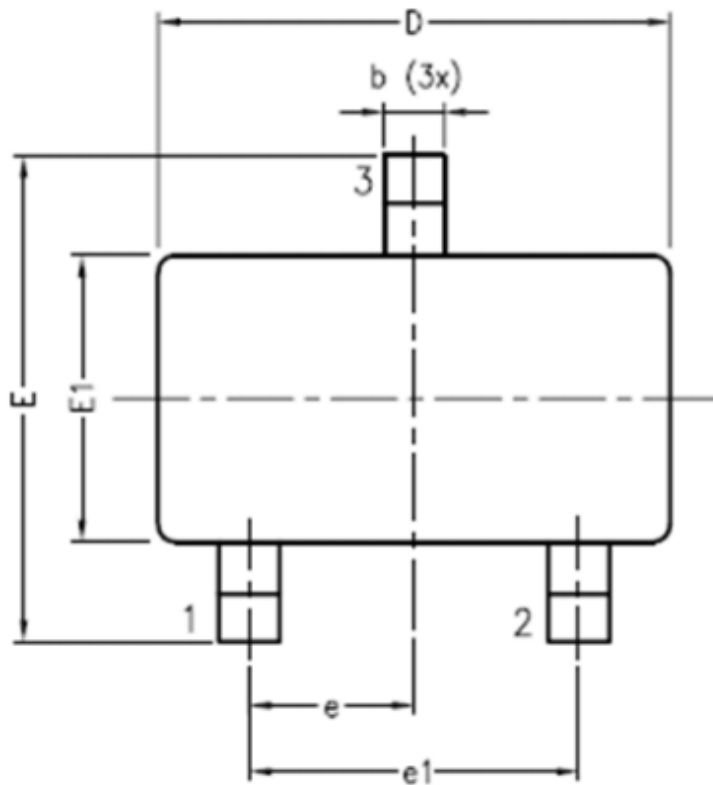
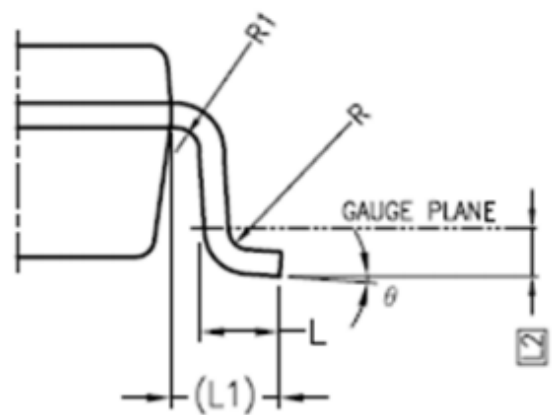
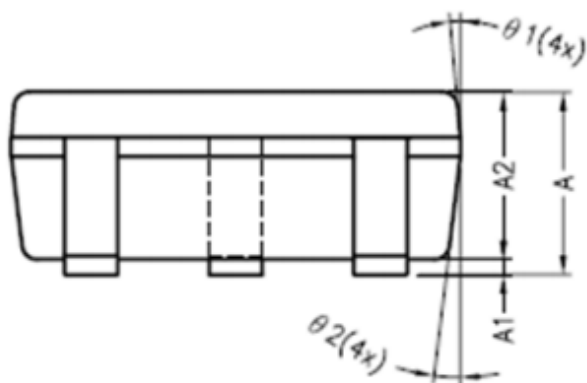

Figure 4: Package Dimensions (For reference only. mm)



SEE VIEW B



VIEW B

NOTE :

1. ALL DIMENSIONS ARE IN MILLIMETERS.
2. DIMENSION D DOES NOT INCLUDE MOLD FLASH, PROTRUSION OR GATE BURRS. MOLD FLASH PROTRUSIONS OR GATE BURRS SHALL NOT EXCEED 0.25 mm PER END. DIMENSION E1 DOES NOT INCLUDE INTERLEAD FLASH OR PROTRUSION. INTERLEAD FLASH OR PROTRUSION SHALL NOT EXCEED 0.25 mm PER SIDE.
3. THE PACKAGE TOP MAY BE SMALLER THAN THE PACKAGE BOTTOM. DIMENSIONS D AND E1 ARE DETERMINED AT THE OUTERMOST EXTREMES OF THE PLASTIC BODY EXCLUSIVE OF MOLD FLASH, TIE BAR BURRS, GATE BURRS AND INTERLEAD FLASH, BUT INCLUDING ANY MISMATCH BETWEEN THE TOP AND BOTTOM OF THE PLASTIC BODY.
4. DIMENSION "b" DOES NOT INCLUDE DAMBAR PROTRUSION. ALLOWABLE DAMBAR PROTRUSION SHALL BE 0.08 mm TOTAL IN EXCESS OF THE "b" DIMENSION AT MAXIMUM MATERIAL CONDITION. THE DAMBAR CANNOT BE LOCATED ON THE LOWER RADIUS OF THE FOOT. MINIMUM SPACE BETWEEN PROTRUSION AND AN ADJACENT LEAD SHALL NOT BE LESS THAN 0.07 mm.
5. LEAD FRAME MATERIAL : EFTEC 64T

SYMBOLS	DIMENSIONS IN MILLIMETERS		
	MIN	NOM	MAX
A	1.05	1.20	1.35
A1	0.00	0.10	0.15
A2	1.00	1.10	1.20
b	0.30	—	0.50
b1	0.30	0.35	0.45
c	0.08	—	0.22
c1	0.08	0.13	0.20
D	2.80	2.90	3.00
E	2.60	2.80	3.00
E1	1.50	1.60	1.70
e	0.95 BSC		
e1	1.90 BSC		
L	0.35	0.43	0.60
L1	0.60 REF		
L2	0.25 BSC.		
R	0.10	—	—
R1	0.10	—	0.25
θ	0°	4°	8°
θ1	5°	6°	15°
θ2	5°	8°	15°



Figure 5: Sensor Polarity Configuration

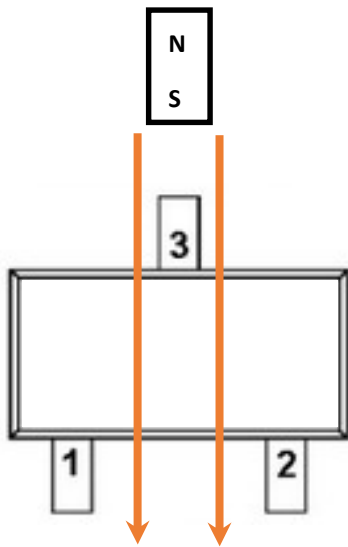
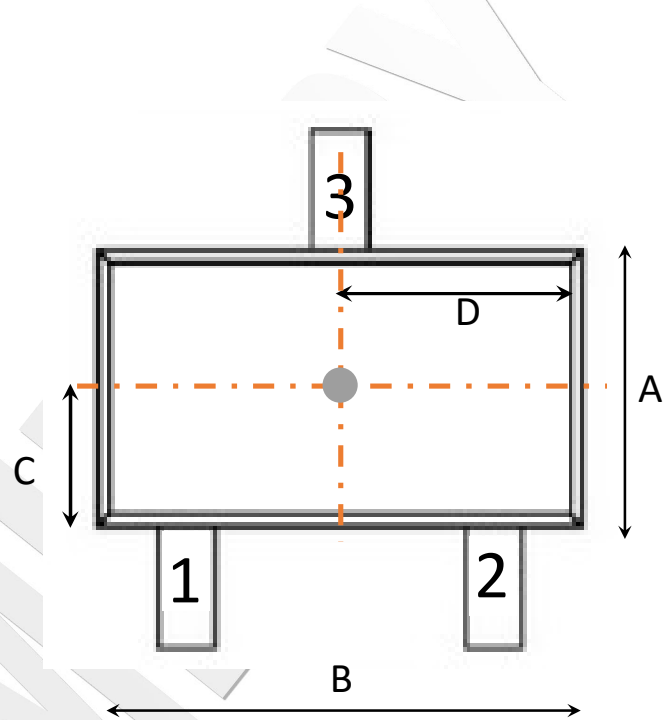

Figure 6: MLU Sensor Location



Symbols	Nominal Dimensions
A	1.60
B	2.90
C	0.80
D	1.45

Table 7: Order Guide

Part Number	Output	Operating Temperature	Description
CT511VA-IS3 CT511VB-IS3 CT511VC-IS3	Digital	-40 to 85 °C	CT511 Series Unipolar magnetic switch with open drain output, SOT-23 Package, Tape-and-reel packaging (3,000 units per reel)

Figure 7: Part Number Legend

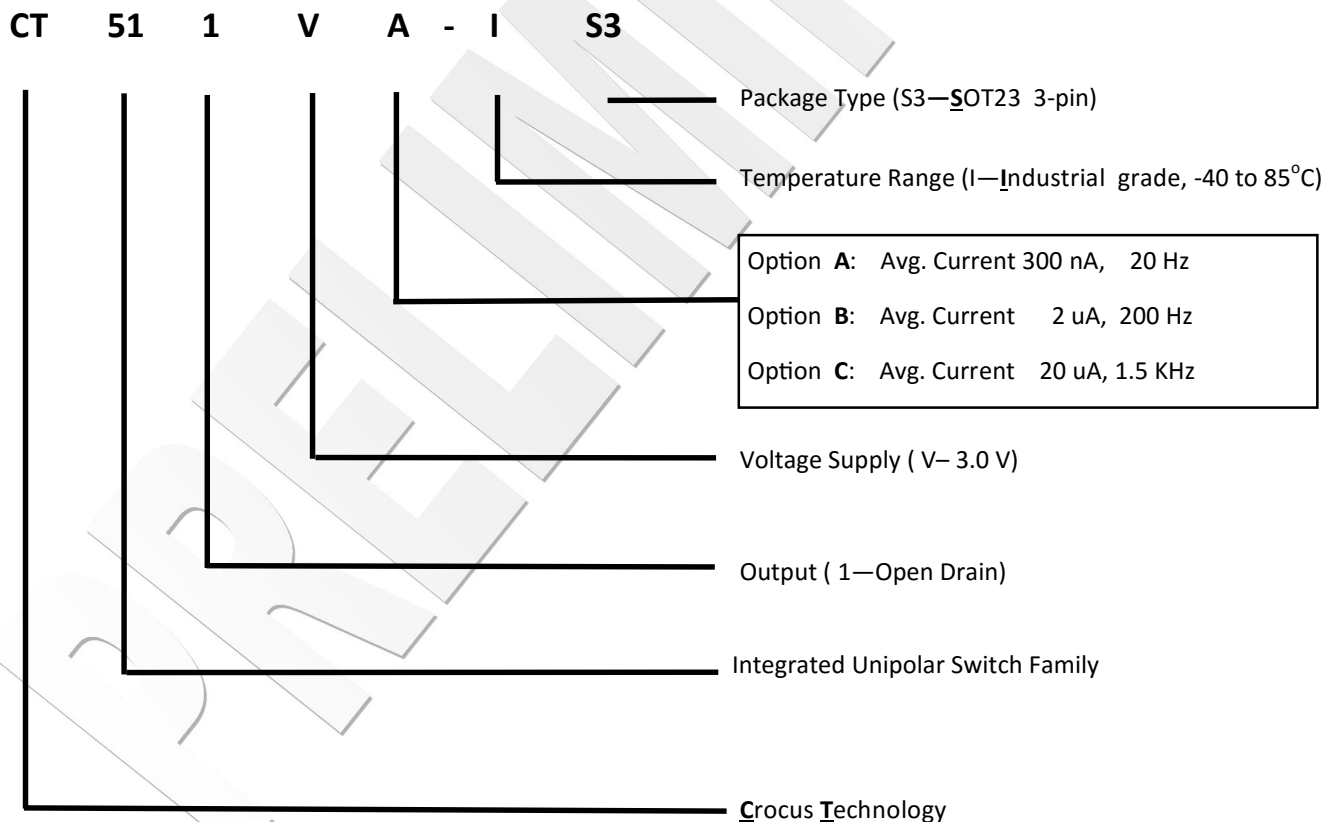

Disclaimer: The contents of this document are provided in connection with products of Crocus Technology (Crocus). CROCUS TECHNOLOGY MAKES NO REPRESENTATIONS OR WARRANTY OF ANY KIND, EXPRESS OR IMPLIED, WITH RESPECT TO THE ACCURACY OR COMPLETENESS OF THE CONTENTS HEREIN, INCLUDING, BUT NOT LIMITED TO, THE IMPLIED WARRANTIES OF MERCHANTABILITY AND FITNESS FOR A PARTICULAR PURPOSE AND RESERVES THE RIGHT TO MAKE CHANGES TO THE SPECIFICATIONS AND PRODUCT DESCRIPTIONS AT ANY TIME WITHOUT NOTICE. Crocus reserves the right to discontinue or make changes to its products at any time without notice. Crocus's products have not been designed, tested, or manufactured for use and should not be used in applications where the failure, malfunction or inaccuracy of the Products carries a risk of death or serious bodily injury or damage to tangible property, including, but not limited to, life support systems, nuclear facilities, military, aircraft navigation or communication, emergency systems, harsh environments, or other applications with a similar degree of potential hazard.

ATTRIBUTION

© 2015 Crocus Technology, Inc. and Crocus Technology SA. All rights reserved. Crocus Technology, Blossoming Future, MLU, and combinations thereof are trademarks of Crocus Technology, Inc. and Crocus Technology SA.

X-ON Electronics

Largest Supplier of Electrical and Electronic Components

Click to view similar products for [Board Mount Hall Effect/Magnetic Sensors](#) category:

Click to view products by [Crocus](#) manufacturer:

Other Similar products are found below :

[HGPRDT005A](#) [AH277AZ4-AG1](#) [AV-10379](#) [AV-10448](#) [SS41C](#) [AH1894-Z-7](#) [ATS601LSGTN-LT-WU4-T](#) [TLE4917](#) [50017859-003](#) [TY-13101](#) [TLE4976L](#) [AH49FNTR-G1](#) [SS85CA](#) [AH277AZ4-BG1](#) [TLE49614MXTSA1](#) [AH3377-P-B](#) [AH211Z4-AG1](#) [AH3360-FT4-7](#) [SS460S-100SAMPLE](#) [50065820-03](#) [TLE4941PLUSCB](#) [AH374-P-A](#) [AH1806-P-A](#) [AH374-W-7](#) [SS460P-T2](#) [AH1913-W-7](#) [SS413F](#)
[TLE5046ICAKLRHALA1](#) [TLE49421CHAMA2](#) [TLE4941PLUSCXAMA1](#) [AH1912-W-EVM](#) [AH1903-FA-EVM](#) [AH3774-W-EVM](#)
[AH49FNTR-EVM](#) [MMC5633NJL](#) [AH3360-FA-EVM](#) [AH8502-FDC-EVM](#) [AH3366Q-SA-EVM](#) [AH3774-P-EVM](#) [KTH1601SU-ST3](#)
[MG910](#) [MG910M](#) [MG911](#) [MG610](#) [MW921](#) [MW922](#) [TLE4998S3XALA1](#) [TLE5011FUMA1](#) [TLE5027CE6747HAMA1](#)
[TLE5109A16E2210XUMA1](#)