

Millenium II +: general characteristics

- Starter kit
- Special starter kits
- Level detection
- Standard
- Expandable
- Blind
- Bare board
- Local extensions
- Adjacent extensions
- Communication modules
- Temperature sensors
- Power supply
- Accessories

Insulation	7 MΩ
Safety class	0 industrial / II domestic casing
Earthing	None
Protection	IP20 / Terminal block IP40 IP00 for CN12 and CN20
Certifications	CE, UL, cUL
Conformity to standards	EN 60947-1 EN 60730-1 EN 60601-1
Programming method	Function blocks/SFC
Program size	128 blocks
Program memory	Flash EEPROM
Removable memory	EEPROM
Data memory	256 bits / 64 words backed up for 10 years
LCD display	Display with 4 lines of 12 characters
Real-time clock	Drift < 1 min/month at 25 °C with user-definable correction of drift Data retention : 10 years (lithium battery)
Storage temperature (°C)	-40 → +70
Operating temperature (°C)	-5 → +55
Relative humidity (no condensation)	90 → 95 %
Dimensions (l x h x w)	SA12-EC12 : 72 x 90 x 60 mm SA20-XT20 : 125 x 90 x 60 mm EC20-EX20 CN12 : 72 x 90 x 42 mm CN20 : 125 x 90 x 42 mm

Electrical characteristics	
Power supply 100 - 240 V AC	
Operating voltage	100 V AC → 240 V AC +10 % -15 % 50/60 Hz
Operating limits	85 V AC → 264 V AC
Immunity from micro power cuts	10 ms
Maximum inrush current	5 A
Max. absorbed power	SA12-EC12-CN12 : 6 VA SA20-EC20-CN20 : 6.5 VA XT20-EX20 : 8 VA

Power supply 24 V AC	
Operating voltage	24 V AC +10 % -15 % 50/60 Hz
Operating limits	20.4 V AC → 28.8 V AC
Immunity from micro power cuts	10 ms
Maximum inrush current	2.5 A
Max. absorbed power	SA12-EC12-CN12 : 6 VA SA20-EC20-CN20 : 6.5 VA XT20-EX20 : 8 VA

Power supply 24 V DC	
Operating voltage	24 V DC +20 % -15 %
Operating limits	20.4 V DC → 28.8 V DC
Immunity from micro power cuts	1 ms
Maximum inrush current	6 A
Max. absorbed power	SA12-EC12-CN12 : 3.5 W SA20-EC20-CN20 : 4 W XT20-EX20 : 5 W

Power supply 12 V DC	
Operating voltage	12 V DC +30% -15% +30% -11% for XT20 relay 88 950 065
Operating limits	10.2 V DC → 15.6 V DC 10.68 VDC → 15.6 V DC for XT 20 relay 88 950 065
Immunity from micro power cuts	1 ms
Maximum inrush current	6 A
Max. absorbed power	SA12-EC12-CN12 : 2.2 W SA20-EC20-CN20 : 4.5 W XT20-EX20 : 5.5 W

100 - 240 V AC input	
Input voltage (V AC)	100 - 240 (+10 % / -15 %)
Supply frequency range (Hz)	50/60 Hz
Input impedance (kΩ)	700
Pull-in voltage at logic state 1 (V AC)	≥ 80
Drop-out voltage at logic state 0 (V AC)	≤ 40
Response time	50
Status indicator	On LCD screen for SA12, SA20 and XT20

24 V AC input	
Input voltage (V AC)	24 (+10 % / -15 %)
Supply frequency range	50/60 Hz
Input impedance (kΩ)	4
Pull-in voltage at logic state 1 (V AC)	≥ 15
Drop-out voltage at logic state 0 (V AC)	≤ 5
Response time	50 ms
Status indicator	On LCD screen for SA12, SA20 and XT20

Analogue input (24 V DC model only)	
CN12-SA12-EC12	4 inputs from I5 to I8
CN20-SA20-EC20-XT20	8 inputs from I5 to I12
Measurement range	(0 → 10 V) or (0 → V power supply)
Resolution	8 bits
Conversion time	10 ms
Max input voltage	28.8 V DC
Input impedance (kΩ)	> 22
Accuracy	+/- 5 %
Drift Temperature	+/- 3 LSB
Potentiometer control	2.2 kΩ / 0.5 W

24 V DC input	
Current drain	24 (+20 % -15 %) V DC
Input current	3.2 mA / 5.5 mA max.
Input impedance	6.8 kΩ
Pull-in voltage at logic state 1	≥ 15 V DC
Drop-out voltage at logic state 0	≤ 5 V DC
Response time	10 ms
Galvanic isolation	No
Sensor type	Contact or 3-wire PNP or 3-wire NPN
Status indicator	On LCD screen for SA12, SA20 and XT20

12 V DC input

Input voltage	12 (+30 % -15 %) V DC (except XT20R +30 % -11 %)
Input current	1.9 mA / 2.3 mA max.
Input impedance	6.45 kΩ
Pull-in voltage at logic state 1	≥ 8 V DC
Drop-out voltage at logic state 0	≤ 3 V DC
Response time	10 ms
Sensor type	Contact or PNP or 3-wire NPN
Galvanic isolation	No
Status indicator	On LCD screen for SA12, SA20 and XT20

Analogue input (12 V DC model only)

CN12 - SA12 - EC12	4 inputs I5 to I8
CN20-SA20-EC20-XT20	8 inputs I5 to I8
Measurement range	0 → 10 V
Resolution	8 bits
Conversion time (ms)	10
Max input voltage	15.6 V DC
Input impedance (kΩ)	> 10 (14 typically)
Precision	± 5 %
Temp. dependent derating	± 3 LSB
Potentiometer control	2.2 kΩ / 0.5 W

Relay output

Max. breaking voltage	250 V AC / 30 V DC
Breaking current	8 A
Service life	8 A / 250 V AC resistive (100 000 operations)
Minimum load	10 mA to 5 V DC
Response time	10 ms
Status indicator	On LCD screen for SA12, SA20 and XT20

TOR / PWM solid state output

PWM solid state output	SA12-EC12-CN12 : O1 to O4 SA20-XT20-EC20-CN20 : O1 to O6
Breaking current	5-28.8 V DC
Breaking voltage	0.7 A / 5-28.8 V DC
Min. load	1 mA
Maximum inductive load	0.7 A
Maximum incandescent load	0.1 A
Leakage	0.1 mA / 24 V DC
Response time	1 ms
Insulation	No
PWM frequency	120 Hz to 1920 Hz (user-definable)
PWM cyclic ratio	0 to 100 % (256 steps)
PWM precision at 120 Hz	< 5 % (from 15 % to 85 %) load at 10 mA
PWM precision at 500 Hz	< 10 % (from 20 % to 80 %) load at 10 mA
Status indicator	On LCD screen for SA12, SA20 and XT20

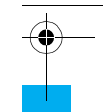
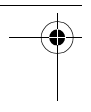
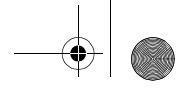

→ Starter kit

- Discover the benefits of Millenium II+
- Each kit includes :
 - a standard or expandable Millenium II+
 - a PC/Millenium programming cable
 - an interactive CD-Rom including the software workshop, tutorial, application library and technical brochures.



Specifications

Type	Input	Output	Supply	Code
KIT SA 12	8	4 relays	24 VDC	88 950 070
	8	4 relays	100 - 240 V AC	88 950 071
Kit SA 20	12	8 relays	24 V DC	88 950 072
	12	8 relays	100 - 240 VAC	88 950 073
Kit XT 20	12	8 relays	24 V DC	88 950 074
	12	8 relays	100 - 240 V AC	88 950 075

→ Special starter kits

- Special Millenium II kits with all the extras needed for your application
- Each kit includes :
 - a standard or expandable Millenium II+
 - a PC/Millenium programming cable
 - an interactive CD-ROM including the software workshop, tutorial, application library and technical brochures.



Specifications

Type	Designation	Supply	Code
Level control KIT	Level control	24 V AC	88 950 076
Temperature control KIT	Heating, cooling and air conditioning	24 V DC	88 950 077

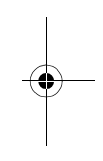
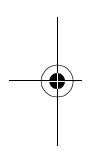

→ Standard

- Intuitive programming via function block (FBD) or grafcet (SFC)
- Function : timing, counting, etc
- Application-specific functions : rotation, cam timers, calculation, etc
- Discrete, analogue or potentiometer inputs
- Relay, solid state or PWM outputs
- Backlit LCD display
- Program password protection
- Integral calendar and clock
- User-definable from the front panel
- Non-expandable



Specifications

Type	Input	Output	Supply	Code
SA 12	8 PNP	4 relays	24 VDC	88 950 041
	8	4 relays	100 - 240 VAC	88 950 043
	8	4 relays	24 VAC	88 950 044
	8 PNP	4 solid state	24 VDC	88 950 042
	8 PNP	4 relays	12 V DC	88 950 045
	8 PNP	4 solid state	12 V DC	88 950 046
	8 NPN	4 relays	24 VDC	88 950 049
	8 NPN	4 relays	24 VDC	88 950 051
SA 20	12 PNP	8 relays	24 VDC	88 950 053
	12	8 relays	100 - 240 VAC	88 950 054
	12	8 relays	24 VAC	88 950 054
	12 PNP	8 solid state	24 VDC	88 950 052
	12 PNP	8 relays	12 V DC	88 950 055
	12 PNP	8 solid state	12 V DC	88 950 056
	12 NPN	8 relays	24 VDC	88 950 059
	12 NPN	8 relays	24 VDC	88 950 059

Dimensions

SA 12

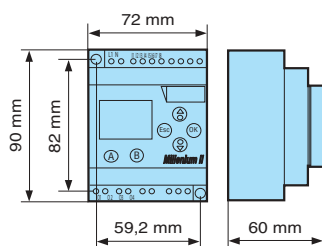

SA 20

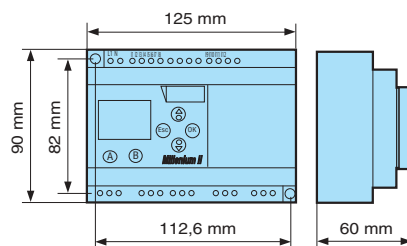

General characteristics

see page 25

→ Level detection

- Intuitive programming via function block (FBD) or grafset (SFC)
- Function : timing, counting, etc
- Application-specific functions : rotation, cam timers, calculation, etc
- Discrete, analogue or potentiometer inputs
- Relay, solid state or PWM outputs
- Backlit LCD display
- Program password protection
- Integral calendar and clock
- User-definable from the front panel
- Non-expandable



Specifications

Type	Input	Output	Supply	Code
SA 12 + level sensor adaptor	8	4 relays	24 V AC	88 950 813

Dimensions

SA 12

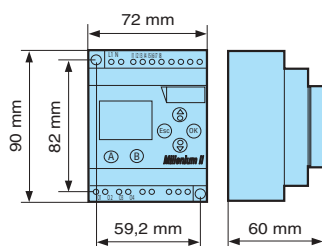

Level sensor adaptor

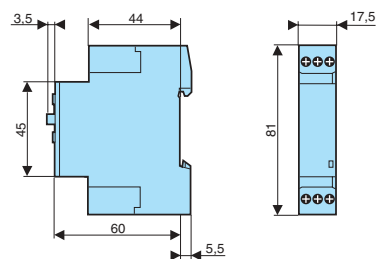

→ Expandable

- Expandable : communication, inputs/outputs, etc
- Intuitive programming via function block (FBD) or grafcet (SFC)
- Function : timing, counting, etc
- Application-specific functions : rotation, cam timers, calculation, etc
- Discrete, analogue or potentiometer inputs
- Relay, solid state or PWM outputs
- Backlit LCD display
- Program password protection
- Integral calendar and clock
- User-definable from the front panel
- Can take an XC adjacent extension and an XL local extension



Specifications

Type	Input	Output	Supply	Code
XT 20	12 PNP	8 relays	24 VDC	88 950 061
	12 PNP	8 relays	100 - 240 VAC	88 950 063
	12 PNP	8 relays	24 VAC	88 950 064
	12 PNP	8 solid state	24 VDC	88 950 062
	12 PNP	8 relays	12 V DC	88 950 065
	12 PNP	8 solid state	12 V DC	88 950 066
	12 NPN	8 relays	24 VDC	88 950 069
EX 20	12 PNP	8 relays	24 V DC	88 950 831
	12	8 relays	100 - 240 V AC	88 950 833
	12	8 relays	24 V AC	88 950 834
	12 PNP	8 solid state	24 V DC	88 950 832
	12 NPN	8 relays	24 V DC	88 950 839

Dimensions

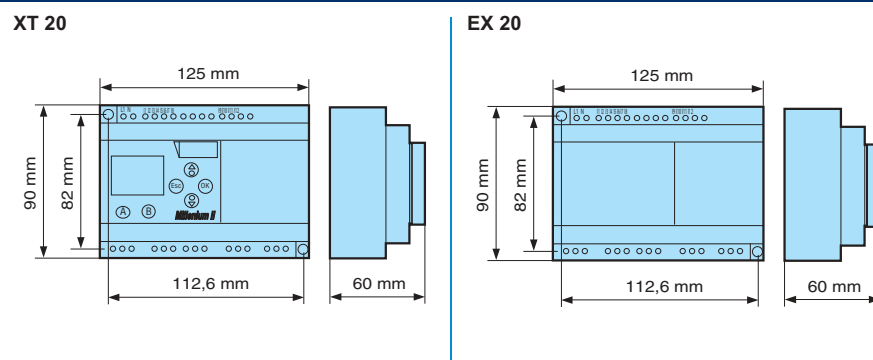

General characteristics

see page 25

→ Blind

- No display or parameter-setting buttons
- Intuitive programming via function block (FBD) or grafcet (SFC)
- Function : timing, counting, etc
- Application-specific functions : rotation, cam timers, calculation, etc
- Discrete, analogue or potentiometer inputs
- Relay, solid state or PWM outputs
- Program protected by a password
- Integral calendar and clock



Specifications

Type	Input	Output	Supply	Code
EC12	8 PNP	4 relays	24 VDC	88 950 021
	8	4 relays	100 - 240 VAC	88 950 023
	8	4 relays	24 VAC	88 950 024
	8 PNP	4 solid state	24 VDC	88 950 022
	8 PNP	4 relays	12 V DC	88 950 025
	8 PNP	4 solid state	12 V DC	88 950 026
	8 NPN	4 relays	24 VDC	88 950 029
	EC 20	12 PNP	8 relays	24 VDC
12		8 relays	100 - 240 VAC	88 950 033
12		8 relays	24 VAC	88 950 034
12 PNP		8 solid state	24 VDC	88 950 032
12 PNP		8 relays	12 V DC	88 950 035
12 PNP		8 solid state	12 V DC	88 950 036
12 NPN		8 relays	24 VDC	88 950 039

Dimensions

EC 12

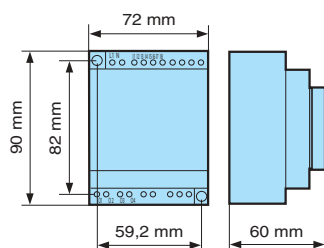

EC 20

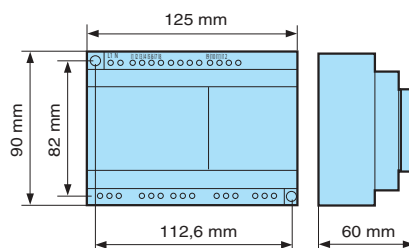

General characteristics

see page 25

→ Bare board

- For mass-production applications
- Intuitive programming via function block (FBD) or grafcet (SFC)
- Function : timing, counting, etc
- Application-specific functions : rotation, cam timers, calculation, etc
- Discrete, analogue or potentiometer inputs
- Relay, solid state or PWM outputs
- Program protected by password
- Integral calendar and clock

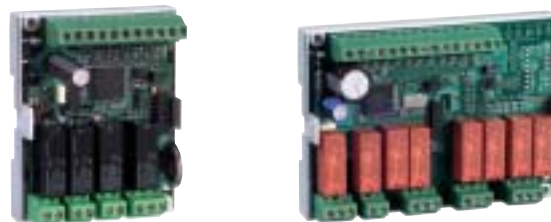

Specifications

Type	Input	Output	Supply	Code	
CN 12	8 PNP	4 relays	24 V DC	88 950 001	
	8	4 relays	100 - 240 V AC	88 950 003	
	8	4 relays	24 V AC	88 950 004	
	8 PNP	4 solid state	24 V DC	88 950 002	
	8 PNP	4 relays	12 V DC	88 950 005	
	8 PNP	4 solid state	12 V DC	88 950 006	
	8 NPN	4 relays	24 V DC	88 950 009	
	CN 20	12 PNP	8 relays	24 V DC	88 950 011
		12	8 relays	100 - 240 V AC	88 950 013
12		8 relays	24 V AC	88 950 014	
12 PNP		8 solid state	24 V DC	88 950 012	
12 PNP		8 relays	12 V DC	88 950 015	
12 PNP		8 solid state	12 V DC	88 950 016	
12 NPN		8 relays	24 V DC	88 950 019	

Dimensions

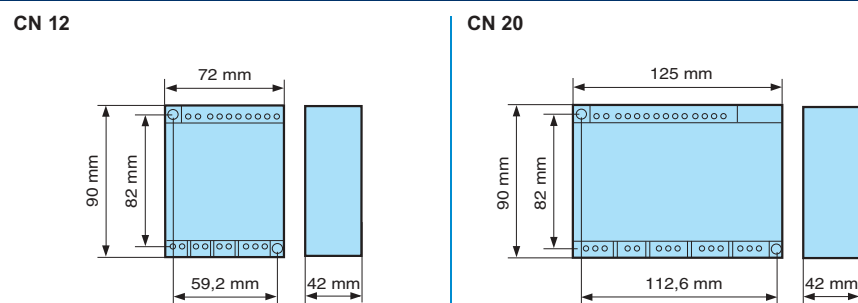

General characteristics

see page 25



→ Local extensions

- For XT 20 only (1 local extension per module)
- Millenium - Millenium local link
- Doubles the hardware and software capacities
- Transparent communication between two XT 20 units
- Max. distance between two XT 20 units : 10 metres
- Cable type : screened twisted pair



Specifications

Type	Designation	Supply	Code
XL 01	M2 - M2 local link (2 modules)	universal	88 950 200
XL 05	4 solid state outputs	universal	88 950 204
XL 06	2 Relay outputs (250mA Maximum)	100 → 240 V AC	88 950 810

→ Adjacent extensions

- For XT 20 only (one adjacent extension per module)
- 4 or 6 additional inputs/outputs



Specifications

Type	Designation	Supply	Code
XC 01	4 inputs PNP 2 relay outputs	24 V DC	88 950 210
	4 inputs relay outputs	24 V AC	88 950 211
	4 inputs 2 relay outputs	100 - 240 V AC	88 950 212
	4 inputs 2 relay outputs	12 V DC	88 950 215
	4 inputs NPN 2 relay outputs	24 V DC	88 950 219

Dimensions

XC 01

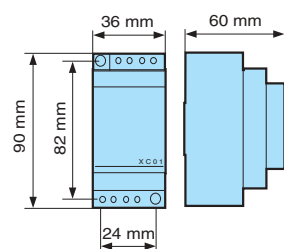

20



→ Communication modules

- For XT 20 only (one adjacent extension per module)
- Communication using MODBUS or AS-i protocol (Slave module)



Specifications

Type	Designation	Supply	Code
XC 02	AS-i communication module 24 V DC	24 V DC	88 950 213
XC 03	MODBUS communication module 24 V DC	24 V DC	88 950 214
Modems	STN		88 950 106
	GSM		88 950 107

Dimensions

xc02/xc03

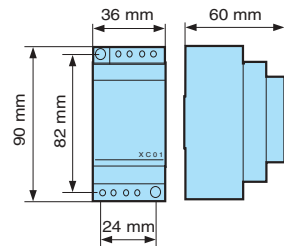

modem

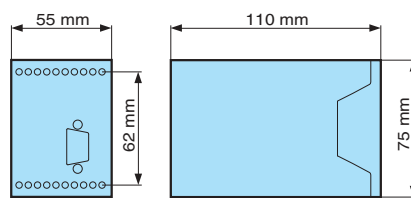



→ Temperature sensors

- Built-in converter : 0-10 V DC output
- Applications : Industrial and domestic



Specifications

Type	Range	Accuracy	Protection casing	Protection probe	Code
Zone	-10 → +40 °C	-0.2 °C +1.2 °C	IP30		89 750 150
Ventilation duct	-10 → +40 °C	-0.2 °C +1.9 °C	IP65	IP30	89 750 151
Outdoor	-10 → +40 °C	-0.2 °C +1.2 °C	IP65		89 750 152
Remote/submersible probe	-10 → +150 °C	-0.2 °C +1.2 °C	IP65	IP67	89 750 153
Outdoor	-40 → +20 °C	-0.2 °C +1.9 °C	IP65	IP67	89 750 155

Accessories

Type	Operating temperature (°C)	Operating pressure (bar)	Code
Copper protective sleeve for 89 750 153	-20 → +100	10	89 750 146
Stainless steel (316) protective sleeve for 89 750 153	-20 → +400	16	89 750 147
Heat transfer compound	-	-	18 372 112

General characteristics

Supply voltage	24 V DC (±10 %)
Output	0 → 10 V DC
Temperature coefficients Derating	0.01 % / °C of full scale
Temperature coefficients Offset	1.5 mV / °C
Ambient temperature (°C)	-10 → +60
Ambient humidity	5 → 95 % RH
Material housing	Self-extinguishing

Dimensions

89 750 150

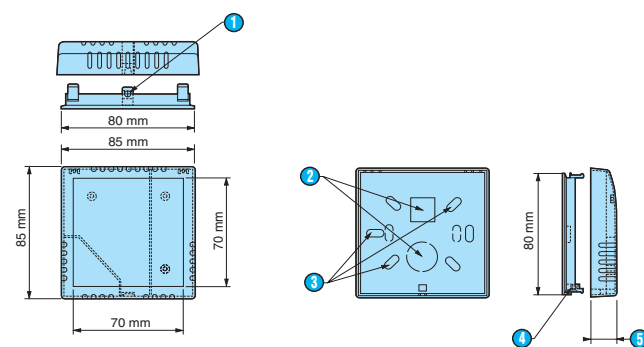

- 1 Ø3 mm for screw M3 x 8
- 2 Cut-outs
- 3 Fixing holes
- 4 Bolt hole M3
- 5 Maximum thickness 26 mm

89 750 151

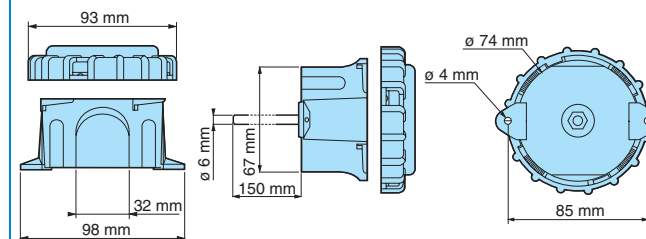

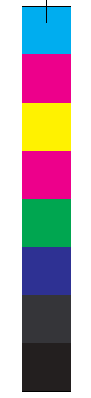
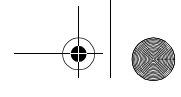
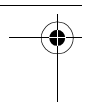

89 750 152

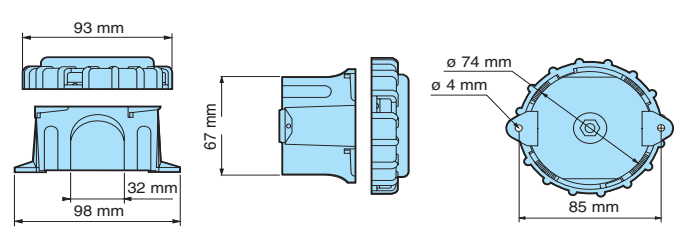

89 750 153 and 89 750 155

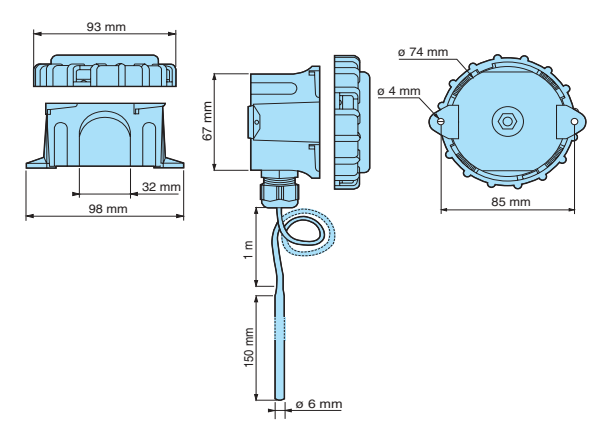

Accessories for 89 750 153 and 89 750 155

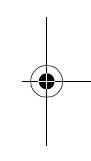
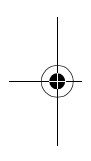
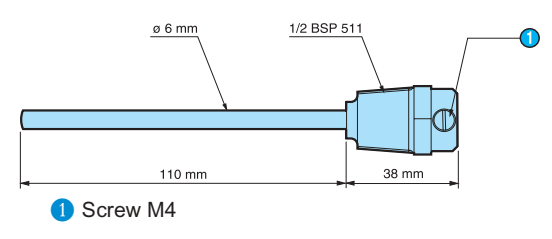

→ Modular power supply

- The output voltage can be adjusted from 100 to 120 % with a potentiometer in order to compensate for possible voltage drops.
- Output voltage existence is indicated by a continuously lit LED. A flashing LED indicates an autoprotection mode.
- Regulated, power surge and short circuit safe, the new switching power supplies easily fit into control panels.



Specifications

Type	Voltage	Nominal power	Code
PS	12 V DC	22 W	88 950 300
	24 V DC	30 W	88 950 301

General characteristics

Input voltage	100 → 240 V AC single phase
Output voltage	88 950 300 : 12 V DC 88 950 301 : 24 V DC ajustable de 100 à 120 %
Nominal power	88 950 300 : 22W 88 950 301 : 30W
Technology	Electronic with primary decoupling
Short-circuit protection	•
Overload protection	•
Reset after overload	automatic
Status indication	Output LED
Mounting	DIN rail EN 50022
Conformity to standards	EN 50081-1 EN 50082-1 CEI 61000-8-2 CEI 950
Certifications	CE, UL-CSA, TÜV, CTick

Dimensions

PS

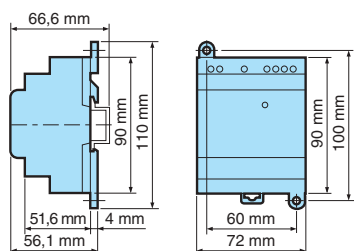

Accessories

→ Front panel adaptors



Specifications

Type	Designation	Code
Front panel adaptor	Front panel adaptor for EC12-SA12	89 750 103
	Front panel adaptor for EC20-SA20-XT20-EX20	89 750 109
Waterproof panel	Waterproof panel adaptor for SA12-EC12	89 750 160
	Waterproof panel adaptor for SA20-XT20-EC20-EX20	89 750 161
	Waterproof panel adaptor for SA20-XT20-EC20-EX20 + 1 extension	89 750 162

→ Interconnection cables



Specifications

Type	Designation	Code
Programming cables	Programming cable 9-pin D connector	88 950 102
	Programming cable USB	88 950 105
Modem cable		88 950 111

→ Programming tools



Specifications

Type	Designation	Code
Software	Programming software on CD ROM	88 950 100
	Modem installation software	88 950 113
Module	EEPROM memory module	88 950 101

→ Convertors



Specifications

Type	Designation	Input	Output	Code
Convertor 0-20 mA / 0-10 V	Input module 0-20 mA / 0-10 V	4	4	88 950 108
Convertor PWM / 0-10V	Output module PWM 0-10V	1	1	88 950 112

X-ON Electronics

Largest Supplier of Electrical and Electronic Components

Click to view similar products for [USB Cables / IEEE 1394 Cables](#) category:

Click to view products by [Crouzet](#) manufacturer:

Other Similar products are found below :

[68768-0173](#) [FNY-W6003-01](#) [88764-0800](#) [148700-1](#) [17-200621](#) [17-250051P](#) [954](#) [17-200261](#) [AC102012-1](#) [AC102012-2](#) [FTP-629Y601](#) [45-1345-15](#) [45-1358-15](#) [45-1363-15](#) [IP-USB1\(C10\)S-RW](#) [CABLE/RTP/USB/DT](#) [45-1351-15](#) [45-1357-15](#) [45-1433-1](#) [687680278](#)
[USBFTVX2SA2N03A](#) [USBFTV2SA2N03A](#) [USBFTV2SA2N05A](#) [MDM9PH004B](#) [MDM9PH004P](#) [FTP-629Y401](#) [FTP-628Y302](#) [FTP-628Y402](#) [CSMNB9MF-5](#) [FNY-W6022](#) [UA-30AMF-SD7B03](#) [UA-30AMFM-SL7B03](#) [USBAPSCC7202A](#) [17-200641](#) [UES-1001A160](#) [UES-1003A160](#) [USBFTVX7SA2N20A](#) [FTP-629Y602](#) [USBCAMCM100](#) [USB A/F*2 to 2.54 2*5P-SH L=400mm](#) [68784-0075](#) [MINI-SCREW-USB-DATACABLE](#) [19800-010500-200-RS](#) [103-1092-BL-F0050](#) [103-1020-BL-00100](#) [103-1092-BL-F0200](#) [103-1092-BL-F0100](#) [105-1092-BL-00300](#) [105-1092-BL-00200](#) [105-1031-BL-00200](#)