

## Analogue extension XA04 Part number 88970241



- Direct connection of analogue 0-10 V or 0-20 mA or Pt100 inputs (10 bit) can be configured using the M3 Soft software
- 2 analogue 0-10 V or PWM outputs (10 bit) can be configured using the M3 Soft software
- Ramp can be parameterised for outputs used as 0-10 V outputs
- Power supply via the controller

### Part numbers

	Type	Inputs	Outputs	Supply
88970241	XA04	1 analogue (0-10 V / 0-20 mA), 1 analogue (0-10 V / 0-20 mA / Pt100)	2 analogue (0-10 V / PWM)	Via the 24 V DC controller

### Specifications

#### General environment characteristics for CB, CD, XD, XB, XR and XE product types

Certifications	CE, UL, CSA, GL
Conformity to standards (with the low voltage directive and EMC directive)	IEC/EN 61131-2 (Open equipment) IEC/EN 61131-2 (Zone B) IEC/EN 61000-6-2, IEC/EN 61000-6-3 (*) IEC/EN 61000-6-4 (*) Except configuration (88 970 1.1 or 88 970 1.2) + (88 970 250 or 88 970 270) + 88 970 241 class A (class B in a metal enclosure)
Earthing	None
Protection rating	In accordance with IEC/EN 60529 : IP40 on front panel IP20 on terminal block
Overvoltage category	3 in accordance with IEC/EN 60664-1
Pollution	Degree : 2 in accordance with IEC/EN 61131-2
Max operating Altitude	Operation : 2000 m Transport : 3,048 m
Mechanical resistance	Immunity to vibrations IEC/EN 60068-2-6, Fc test Immunity to shock IEC/EN 60068-2-27, Fa test
Resistance to electrostatic discharge	Immunity to ESD IEC/EN 61000-4-2, level 3
Resistance to HF interference	Immunity to radiated electrostatic fields IEC/EN 61000-4-3, Immunity to fast transients (burst immunity) IEC/EN 61000-4-4, level 3 Immunity to shock waves IEC/EN 61000-4-5 Radio frequency in common mode IEC/EN 61000-4-6, level 3 Voltage dips and breaks (AC) IEC/EN 61000-4-11 Immunity to damped oscillatory waves IEC/EN 61000-4-12
Conducted and radiated emissions	Class B (*) in accordance with EN 55022, EN 55011 (CISPR22, CISPR11) group 1 (*) Except configuration (88 970 1.1 or 88 970 1.2) + (88 970 250 or 88 970 270) + 88 970 241 class A (class B in metallic cabinet)
Operating temperature	-20 → +55 °C (+40 °C in a non-ventilated enclosure) in accordance with IEC/EN 60068-2-1 and IEC/EN 60068-2-2
Storage temperature	-40 → +70 °C in accordance with IEC/EN 60068-2-1 and IEC/EN 60068-2-2
Relative humidity	95 % max. (no condensation or dripping water) in accordance with IEC/EN 60068-2-30
Mounting	On symmetrical DIN profile, 35 x 7.5 mm and 35 mm x 15 or panel (2 x 4 mm Ø)
Screw terminals connection capacity	Flexible wire with ferrule = 1 conductor : 0.25 to 2.5 mm <sup>2</sup> (AWG 24...AWG 14) 2 conductors 0.25 to 0.75 mm <sup>2</sup> (AWG 24...AWG 18) Semi-rigid wire = 1 conductor : 0.2 to 2.5 mm <sup>2</sup> (AWG 25...AWG 14) Rigid wire = 1 conductor : 0.2 to 2.5 mm <sup>2</sup> (AWG 25...AWG 14) 2 conductors 0.2 to 1.5 mm <sup>2</sup> (AWG 25...AWG 16) Tightening torque = 0.5 N.m (4.5 lb-in) (tighten using screwdriver diam. 3.5 mm)

#### Characteristics of analogue extension 88970241

General characteristics	
Certifications	IEC/EN 60751
Earthing	Yes, refer to the quick reference guide supplied with the product
Analogue input	

Inputs used as analogue inputs			
Inputs	IP and IQ	IP and IQ	IQ
Input range	0 →10 V DC	0 →20 mA	-25 →125 °C
Input impedance	≥ 18 kΩ	246 Ω	-
Maximum non destructive current/voltage	30 V	30 mA	-
Value of LSB	9,8 mV	20 μA	0,15 °C
Input type	Common mode	Common mode	Pt100 probe - IEC 751 - 3-wire
Resolution	10 bit	10 bit	10 bit
Conversion time	Module cycle time	Module cycle time	Module cycle time
Accuracy at 25 °C	± 2 %	± 2 %	±1.5 °C
Accuracy at 55 °C	± 2 %	± 2 %	±1.5 °C
Isolation between analogue channel and power supply	None	None	None
Cable length	10 m maximum, with shielded cable (sensor not isolated)	10 m maximum, with shielded cable (sensor not isolated)	10 m maximum, with shielded cable (sensor not isolated)
Protection against polarity inversions	Command ignored	Command ignored	Command ignored
Analogue outputs			
Range output	0 →10 V		
Input type	Resistive		
Max. load	10 mA		
Value of LSB	10 mV		
Resolution	10 bit		
Conversion time	Controller cycle time		
Accuracy at 25 °C	±1 % of full scale		
Accuracy at 55 °C	±1 % of full scale		
Repeat accuracy at 55 °C	± 1 %		
Isolation between analogue channel and power supply	None		
Cable length	10 metres maximum, with shielded cable (sensor not isolated)		
Protection against polarity inversions	Yes		
PWM			
Range output	V power supply		
Max. load	≥ 1.2 kΩ (I ≤ 20 mA)		
PWM cyclic ratio	1024 steps (0 - 100 %)		
Frequency	78 Hz, 312,5 Hz, 666,6 Hz, 1000 Hz, 1250 Hz, 1428 Hz, 1666 Hz, 2000 Hz		
Accuracy	1 % across the entire temperature range for PWM ratios from 5 % to 95 %		
Built-in protections	Against overvoltages : Yes		
Processing characteristics of CB, CD, XD & XB product types			
LCD display	CD, XD : Display with 4 lines of 18 characters		
Programming method	Function blocks / SCF (Grafcet) or Ladder		
Program size	For CB, CD : 4 Ko : 64 macros max. 256 blocks max. per macro 180 typical blocks For XB, XD : 8 Ko : 64 macro max. 256 blocks max. per macro 350 typical blocks Or for CB, CD, XB, XD : 120 lines in Ladder		
Program memory	Flash EEPROM		
Removable memory	EEPROM		
Data memory	368 bit/200 words		
Back-up time in the event of power failure	Program and settings in the controller : 10 years Program and settings in the plug-in memory : 10 years Data memory : 10 years		
Cycle time	Function blocks : 6 →90 ms (typically 20 ms) Ladder : typically 20 ms		
Response time	Input acquisition time : 1 to 2 cycle times		
Clock data retention	10 years (lithium battery) at 25 °C		
Clock drift	Drift < 12 min/year (at 25 °C) 6 s/month (at 25 °C with user-definable correction of drift)		
Timer block accuracy	1 % ± 2 cycle times		
Start up time on power up	< 1,2 s		

#### Characteristics of products with AC power supplied

Supply	24 V AC (88970..4)	100 →240 V AC (88970..3)
Nominal voltage	24 V AC	100 →240 V AC
Operating limits	-15 % / +20 % or 20.4 VAC→28.8 VAC	-15 % / +10 % or 85 VAC→264 VAC
Supply frequency range	50/60 Hz (+4 % / -6 %) or 47→53 Hz/57 < 63 Hz	50/60 Hz (+4 % / -6 %) or 47 →53 Hz/57 < 63 Hz
Immunity from micro power cuts	10 ms (repetition 20 times)	10 ms (repetition 20 times)
Max. absorbed power	CB12-CD12-XD10-XB10 : 4 VA CB20-CD20 : 6 VA XD10-XB10 with extension : 7,5 VA XD26-XB26 : 7.5 VA XD26-XB26 with extension : 10 VA	CB12-CD12-XD10-XB10 : 7 VA CB20-CD20 : 11 VA XD10-XB10 with extension : 12 VA XD26-XB26 : 12 VA XD26-XB26 with extension : 17 VA
Isolation voltage	1780 V AC	1780 V AC
Inputs	24 V AC (88970..4)	100 →240 V AC (88970..3)
Input voltage	24 V AC (-15 % / +20 %)	100 →240 V AC (-15 % / +10 %)

Input current	4,4 mA @ 20,4 V AC 5,2 mA @ 24,0 V AC 6,3 mA @ 28,8 V AC	0,24 mA @ 85 V AC 0,75 mA @ 264 V AC
Input impedance	4.6 kΩ	350 kΩ
Logic 1 voltage threshold	≥ 14 V AC	≥ 79 V AC
Making current at logic state 1	>2 mA	>0.17 mA
Logic 0 voltage threshold	≤ 5 V AC	≤ 20 V AC (≤ 28 V AC : XE10, XR06, XR10, XR14)
Release current at logic state 0	<0.5 mA	<0.5 mA
Response time with LADDER programming	50 ms State 0 → 1 (50/60 Hz)	50 ms State 0 < 1 (50/60 Hz)
Response time with function blocks programming	Configurable in increments of 10 ms 50 ms min. up to 255 ms State 0 → 1 (50/60 Hz)	Configurable in increments of 10 ms 50 ms min. up to 255 ms State 0 → 1 (50/60 Hz)
Maximum counting frequency	In accordance with cycle time (Tc) and input response time (Tr) : $1 / ((2 \times Tc) + Tr)$	In accordance with cycle time (Tc) and input response time (Tr) : $1 / ((2 \times Tc) + Tr)$
Sensor type	Contact or 3-wire PNP	Contact or 3-wire PNP
Input type	Resistive	Resistive
Isolation between power supply and inputs	None	None
Isolation between inputs	None	None
Protection against polarity inversions	Yes	Yes
Status indicator	On LCD screen for CD and XD	On LCD screen for CD and XD

#### Characteristics of relay outputs common to the entire range

Max. breaking voltage	5 → 30 V DC 24 → 250 V AC
Breaking current	CB-CD-XB10-XD10-XR06-XR10 : 8 A XD26-XB26 : 8 x 8 A relays, 2 x 5 A relays XE10 : 4 x 5 A relays XR14 : 4 x 8 A relays, 2 x 5 A relays
Electrical durability for 500 000 operating cycles	Usage category DC-12 : 24 V, 1.5 A Usage category DC-13 : 24 V (L/R = 10 ms), 0.6 A Usage category AC-12 : 230 V, 1.5 A Usage category AC-15 : 230 V, 0.9 A
Max. Output Common Current	12A for O8,O9,OA
Minimum switching capacity	10 mA (at minimum voltage of 12 V)
Minimum load	12 V, 10 mA
Maximum rate	Off load : 10 Hz At operating current : 0.1 Hz
Mechanical life	10,000,000 operations (cycles)
Voltage for withstanding shocks	In accordance with IEC/EN 60947-1 and IEC/EN 60664-1 : 4 kV
Off-cycle response time	Make 10 ms Release 5 ms
Built-in protections	Against short-circuits : None Against overvoltages and overloads : None
Status indicator	On LCD screen for CD and XD

#### Characteristics of product with DC power supplied

Supply	12 V DC (88970..5 & 8970814 & 88970840)	24 V DC (88970..1 et 88970..2)
Nominal voltage	12 V DC	24 V DC
Operating limits	-13 % / +20 % or 10.4 V DC < 14.4 V DC (including ripple)	-20 % / +25 % or 19.2 V DC < 30 V DC (including ripple)
Immunity from micro power cuts	≤ 1 ms (repetition 20 times)	≤ 1 ms (repetition 20 times)
Max. absorbed power	CB12 with solid state outputs : 1.5 W CD12 : 1.5 W CD20 : 2.5 W XD26-XB26 : 3 W XD26-XB26 with extension : 5 W XD26 with solid state outputs : 2.5 W	CB12-CD12-CD20 with solid state outputs - XD10-XB10 with solid state outputs : 3 W XD10-XB10 with relay outputs : 4 W XD26-XB26 with solid state outputs : 5 W CB20-CD20 with relay outputs : 6 W XD26 with relay outputs : 6 W XD10-XB10 with extension : 8 W XD26-XB26 with extension : 10 W
Protection against polarity inversions	Yes	Yes
Digital inputs (I1 to IA and IH to IY)	12 V DC (88970..5 & 88970814 & 88970840)	24 V DC (88970..1 and 88970..2)
Input voltage	12 V DC (-13 % / +20 %)	24 V DC (-20 % / +25 %)
Input current	3,9 mA @ 10,44 V DC 4,4 mA @ 12,0 V DC 5,3 mA @ 14,4 VDC	2,6 mA @ 19,2 V DC 3,2 mA @ 24 V DC 4,0 mA @ 30,0 VDC
Input impedance	2.7 kΩ	7.4 kΩ
Logic 1 voltage threshold	≥ 7 V DC	≥ 15 V DC
Making current at logic state 1	≥ 2 mA	≥ 2.2 mA
Logic 0 voltage threshold	≤ 3 V DC	≤ 5 V DC
Release current at logic state 0	<0.9 mA	<0.75 mA
Response time	1 → 2 cycle times + 6 ms	1 → 2 cycle times + 6 ms
Maximum counting frequency	I1 & I2 : FBD (Up to 6 k Hz) & Ladder (1 k Hz) I3 to IA & IH to IY : in accordance with cycle time (Tc) and input response time (Tr) : $1 / ((2 \times Tc) + Tr)$	I1 & I2 : FBD (Up to 6 k Hz) & Ladder (1 k Hz) I3 to IA & IH to IY : in accordance with cycle time (Tc) and input response time (Tr) : $1 / ((2 \times Tc) + Tr)$
Sensor type	Contact or 3-wire PNP	Contact or 3-wire PNP
Conforming to IEC/EN 61131-2	Type 1	Type 1
Input type	Resistive	Resistive
Isolation between power supply and inputs	None	None
Isolation between inputs	None	None
Protection against polarity inversions	Yes	Yes
Status indicator	On LCD screen for CD and XD	On LCD screen for CD and XD

Analogue or digital inputs (IB to IG)	12 V DC (88970..5 & 88970814 & 88970840)	24 V DC (88970..1 and 88970..2)
CB12-CD12-XD10-XB10	4 inputs IB →IE	4 inputs IB →IE
CB20-CD20-XB26-XD26	6 inputs IB →IG	6 inputs IB →IG
Inputs used as analogue input only in FBD		
Measurement range	(0 →10 V) or (0 →V power supply)	(0 →10 V) or (0 →V power supply)
Input impedance	14 kΩ	12 kΩ
Input voltage	14.4 V DC max	30 V DC max
Value of LSB	14 mV	29 mV
Input type	Common mode	Common mode
Resolution	10 bit at maximum input voltage	10 bit at maximum input voltage
Conversion time	Controller cycle time	Controller cycle time
Accuracy at 25 °C	± 5 %	± 5 %
Accuracy at 55 °C	± 6.2 %	± 6.2 %
Repeat accuracy at 55 °C	± 2 %	± 2 %
Isolation between analogue channel and power supply	None	None
Cable length	10 m maximum, with shielded cable (sensor not isolated)	10 m maximum, with shielded cable (sensor not isolated)
Protection against polarity inversions	Yes	Yes
Potentiometer control	2.2 kΩ/0.5 W (recommended) 10 kΩ max.	2.2 kΩ/0.5 W (recommended) 10 kΩ max.
Inputs used as digital inputs		
Input voltage	12 V DC (-13 % / +20 %)	24 V DC (-20 % / +25 %)
Input current	0,7 mA @ 10,44 VDC 0,9 mA @ 12,0 VDC 1,0 mA @ 14,4VDC	1,6 mA @ 19,2 VDC 2,0 mA @ 24,0 V DC 2,5 mA @ 30,0 VDC
Input impedance	14 kΩ	12 kΩ
Logic 1 voltage threshold	≥ 7 V DC	≥ 15 VDC
Making current at logic state 1	≥0.5 mA	≥1.2 mA
Logic 0 voltage threshold	≤ 3 V DC	≤ 5 V DC
Release current at logic state 0	≤0.2 mA	≤0.5 mA
Response time	1 →2 cycle times	1 →2 cycle times
Maximum counting frequency in FBD	In accordance with cycle time (Tc) and input response time (Tr) : 1/ ( (2 x Tc) + Tr)	In accordance with cycle time (Tc) and input response time (Tr) : 1/ ( (2 x Tc) + Tr)
Sensor type	Contact or 3-wire PNP	Contact or 3-wire PNP
Conforming to IEC/EN 61131-2	Type 1	Type 1
Input type	Resistive	Resistive
Isolation between power supply and inputs	None	None
Isolation between inputs	None	None
Protection against polarity inversions	Yes	Yes
Status indicator	On LCD screen for CD and XD	On LCD screen for CD and XD
Characteristics of relay outputs common to the entire range		
Max. breaking voltage	5 →30 V DC 24 →250 V AC	
Max. Output Common Current	12A (10A UL) for O8,O9,OA	
Breaking current	CB-CD-XD10-XB10-XR06-XR10 : 8 A XD26-XB26 : 8 x 8 A relays, 2 x 5 A relays XE10 : 4 x 5 A relays XR14 : 4 x 8 A relays, 2 x 5 A relays	
Electrical durability for 500 000 operating cycles	Usage category DC-12 : 24 V, 1.5 A Usage category DC-13 : 24 V (L/R = 10 ms), 0.6 A Usage category AC-12 : 230 V, 1.5 A Usage category AC-15 : 230 V, 0.9 A	
Minimum switching capacity	10 mA (at minimum voltage of 12 V)	
Minimum load	12 V, 10 mA	
Maximum rate	Off load : 10 Hz At operating current : 0.1 Hz	
Mechanical life	10,000,000 operations (cycles)	
Voltage for withstanding shocks	In accordance with IEC/EN 60947-1 and IEC/EN 60664-1 : 4 kV	
Off-cycle response time	Make 10 ms Release 5 ms	
Built-in protections	Against short-circuits : None Against overvoltages and overloads : None	
Status indicator	On LCD screen for CD and XD	
Digital / PWM solid state output	12 V DC (88970814 & 88970840)	24 V DC (88970..2)
PWM solid state output*	CB12 : O4 XD26 : O4 →O7	CD12-XD10-XB10 : O4 CD20-XD26-XB26 : O4 →O7
* Only available with "FBD" programming language	* Only available with "FBD" programming language	
Breaking voltage	10.4 →30 VDC	19.2 →30 VDC
Nominal voltage	12-24 V DC	24 V DC
Nominal current	0.5 A	0.5 A
Max. breaking current	0,625 A	0,625 A
Voltage drop	≤ 2 V for I = 0.5 A (at state 1)	≤ 2 V for I = 0.5 A (at state 1)
Response time	Make ≤ 1 ms Release ≤ 1 ms	Make ≤ 1 ms Release ≤ 1 ms
Operating frequency	1 Maximum on inductive load	1 Maximum on inductive load
Built-in protections	Against overloads and short-circuits : Yes Against overvoltages (*) : Yes Against inversions of power supply : Yes (*) In the absence of a volt-free contact between the output of the	Against overloads and short-circuits : Yes Against overvoltages (*) : Yes Against inversions of power supply : Yes (*) In the absence of a volt-free contact between the output of the

	logic controller and the load	logic controller and the load
Min. load	1 mA	1 mA
Maximum incandescent load	0,2 A / 12 V DC 0,1 A / 24 V DC	0,1 A / 24 V DC
Galvanic isolation	No	No
PWM frequency	14.11 Hz 56.45 Hz 112.90 Hz 225.80 Hz 451.59 Hz 1806.37 Hz	14.11 Hz 56.45 Hz 112.90 Hz 225.80 Hz 451.59 Hz 1806.37 Hz
PWM cyclic ratio	0 → 100 % (256 steps for CD, XD and 1024 for XA)	0 → 100 % (256 steps for CD, XD and 1024 for XA)
PWM accuracy at 120 Hz	< 5 % (20 % → 80 %) load at 10 mA	< 5 % (20 % → 80 %) load at 10 mA
Max. Breaking current PWM	50 mA	50 mA
Max. cable length PWM	20 m	20 m
PWM accuracy at 500 Hz	< 10 % (20 % → 80 %) load at 10 mA	< 10 % (20 % → 80 %) load at 10 mA
Status indicator	On LCD screen for CD and XD	On LCD screen for CD and XD

#### Dimensions (mm)

XA04

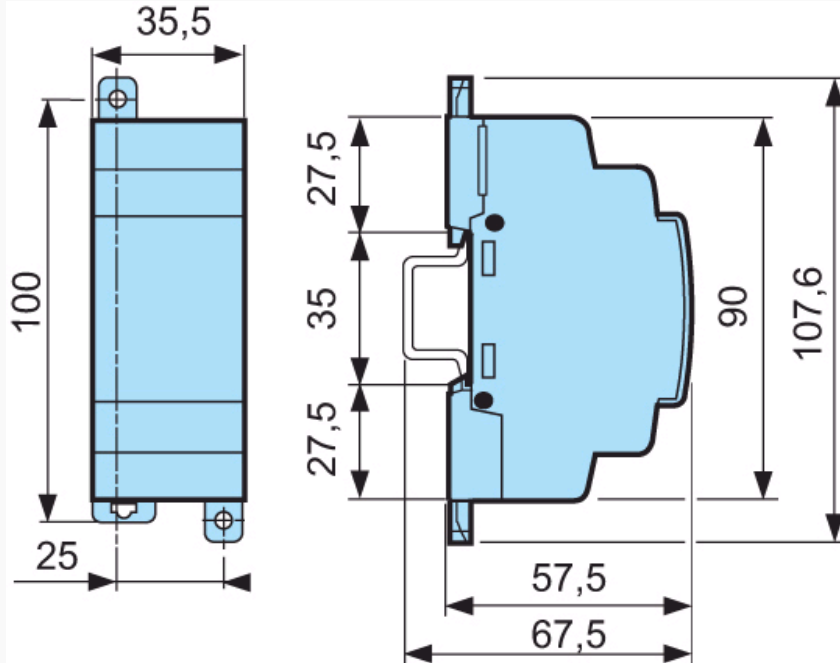

## X-ON Electronics

Largest Supplier of Electrical and Electronic Components

*Click to view similar products for [Controllers](#) category:*

*Click to view products by [Crouzet](#) manufacturer:*

Other Similar products are found below :

[61FGPN8DAC120](#) [CV500SLK21](#) [70177-1011](#) [F03-03 HAS C](#) [F03-31](#) [81550401](#) [FT1A-C12RA-W](#) [88981106](#) [H2CAC24A](#) [H2CRSAC110B](#)  
[R88A-CRGB003CR-E](#) [R88ARR080100S](#) [R88A-TK01K](#) [DCN1-1](#) [AFP0RT32CT](#) [DRT2ID08C](#) [DTB4896VRE](#) [DTB9696CVE](#)  
[DTB9696LVE](#) [E53-AZ01](#) [E53E01](#) [E53E8C](#) [E5C4Q40J999FAC120](#) [E5CWLQ1TCAC100240](#) [E5GNQ03PFLKACDC24](#) [B300LKL21](#)  
[NSCXDC1V3](#) [NSH5-232CW-3M](#) [NT20SST122BV1](#) [NV-CN001](#) [OAS-160-N](#) [C40PEDRA](#) [K31S6](#) [K33-L1B](#) [K3MA-F](#) [100-240VAC](#)  
[K3TX-AD31A](#) [89750101](#) [L595020](#) [SRM1-C02](#) [SRS2-1](#) [G32X-V2K](#) [26546803](#) [26546805](#) [PWRA440A](#) [CPM1AETL03CH](#) [CV500SLK11](#)  
[3G2A5BI081](#) [3G2A5IA122](#) [3G2A5LK010E](#) [3G2A5OA223](#)