

## IQ2306 Speed Module

### 1 Features

- Up to 20% efficiency boost in hover applications
- 4.8% more shaft power than same sized motors
- "Thrust" controller that allows flight controller to be motor and propeller agnostic
- Velocity controller with PID and 2nd order feed forward
- Voltage controller
- PWM controller
- Coast and brake modes
- No minimum speed
- Immediate reversibility (3D mode)
- Backdrivable
- Regenerative braking
- Active freewheeling
- Current limiter
- Temperature limiter
- Serial (UART) w/ access to control parameters
- 1-2ms PWM
- Oneshot (42, 125)
- MultiShot
- DShot (150-1200) (autodetect)

### 2 Applications

- Drones
- Fans
- Wheeled vehicles
- Displays



### 3 Description

The IQ2306 Speed Module is an integrated motor and controller with a wide range of velocity based applications. It has an open and closed loop controller designed primarily to drive propeller loads. Its performance is comparable to or better than other 2306 sized motors and can operate at any speed between -32,000 and 32,000 RPM thanks to its sensed control.

If given thrust coefficients, this controller can be commanded in units of thrust, seamlessly accepting values from flight controllers in their native units. An added benefit is the decoupling of flight controller gains from motor choice, propeller choice, battery level, and more. Thrust commands are fed into a PID velocity controller with a second order polynomial feed forward. This sits on top of a voltage controller, which compensates for varying input voltages. Finally, the core is a raw PWM controller. Any of the above controllers can be used by the user.

## 4 Motor Specifications

Description	Symbol	Value	Unit	Notes
Speed Constant	$K_v$	2200	RPM/V	
Torque/EMF Constant	$K_t$	0.0043	N m A <sup>-1</sup>	
Resistance	$R$	0.038	$\Omega$	motor, 25°C
Effective Resistance	$R_e$	0.045	$\Omega$	motor + controller, 25°C
Mass	$m$	37.4	g	Without wires/accessories
Continuous Torque	$\tau_c$	65	N mm	25°C ambient
Continuous Torque	$\tau_b$	130	N mm	In airflow, 25°C ambient
Continuous Current	$I_S$	15	A	Motor current, 25°C ambient
Continuous Current	$I_{SR}$	30	A	Motor current, in airflow, 25°C ambient
Pulsed Current	$I_{SP}$	65	A	Motor current, 100ms, 25°C ambient
No Load Speed	$\omega_0$	2166	rad s <sup>-1</sup>	@ $V_{CC} = 10\text{ V}$
No Load Current	$I_0$	1.3	A	@ $V_{CC} = 10\text{ V}$

## 5 Electrical Specifications

Description	Symbol	Min	Max	Unit	Notes
Supply Voltage	$V_{CC}$	5	25.2	V	Designed for 2S-6S LiPo, use with caution on 6S
Digital Logic Voltage	$V_L$	-0.3	7.3	V	3.3 V system, 5 V tolerant
Temperature	$T$	-20	105	°C	

## 6 Electrical Interface

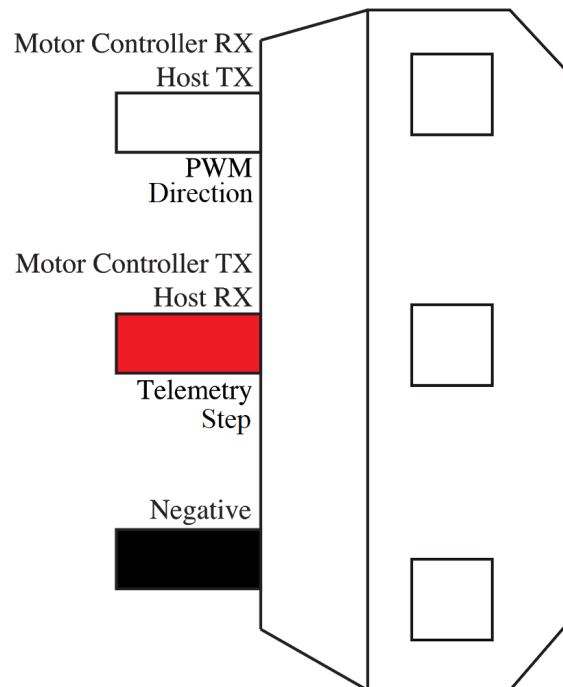

Figure 1: JR Servo Communication Connector

## 6.1 Communication Wiring

The standard communication connector is a JR type servo connector with 15cm of wire. These connectors have 0.1in spacing and can be inserted into standard perfboard and breadboards with a 3x1 0.1in male-to-male header. Black is minus (ground). Red is motor controller TX (host RX) and telemetry output. White is motor controller RX (host TX) and pwm input.

## 6.2 Supply Wiring

Power is transmitted to the IQ2306 Speed Module via the two supplied 16 AWG (1.31 mm<sup>2</sup>), silicone encased, 15cm long wires. Black is minus (ground). Red is positive.

### 7 Mechanical Interface

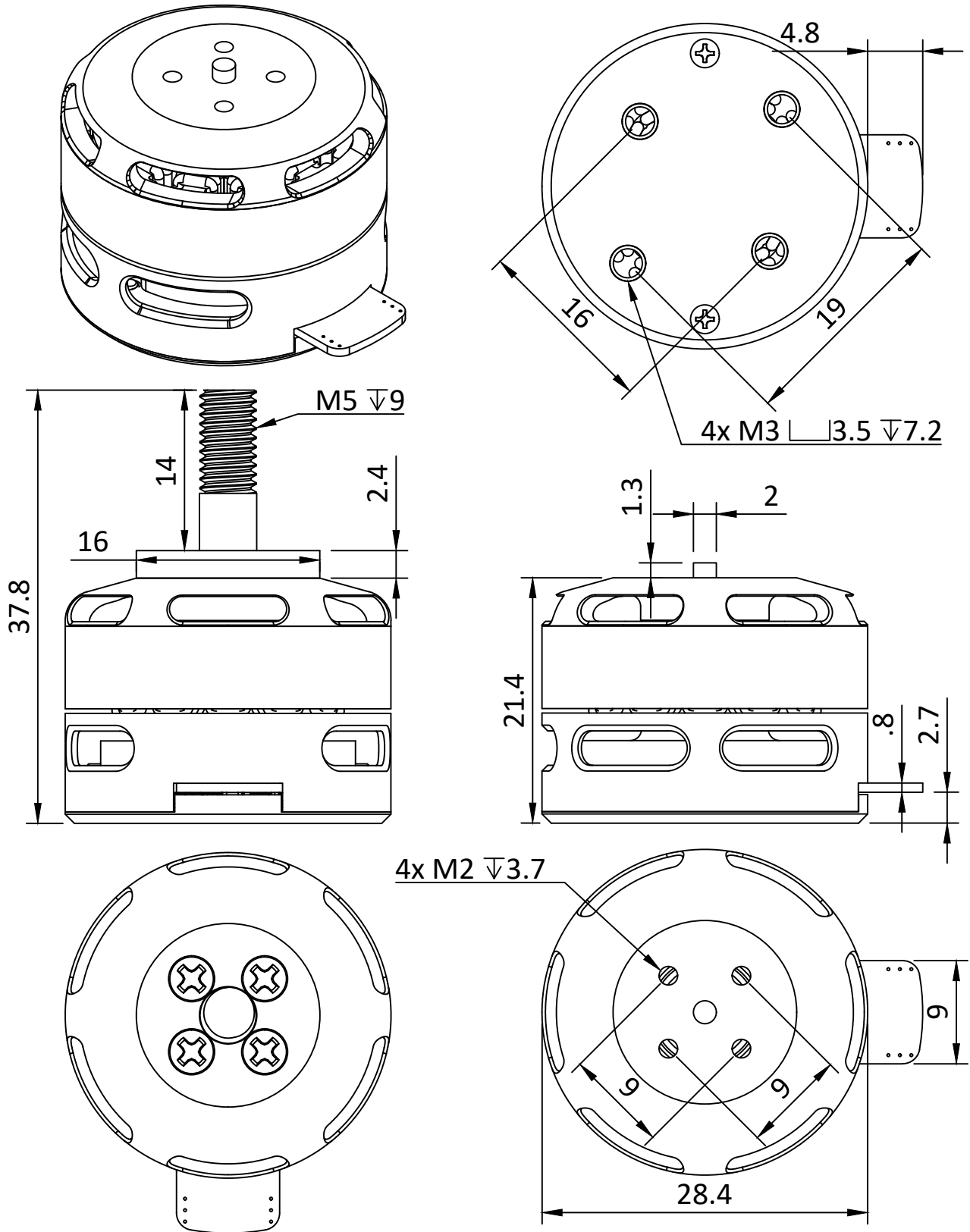

## 8 Motor Performance

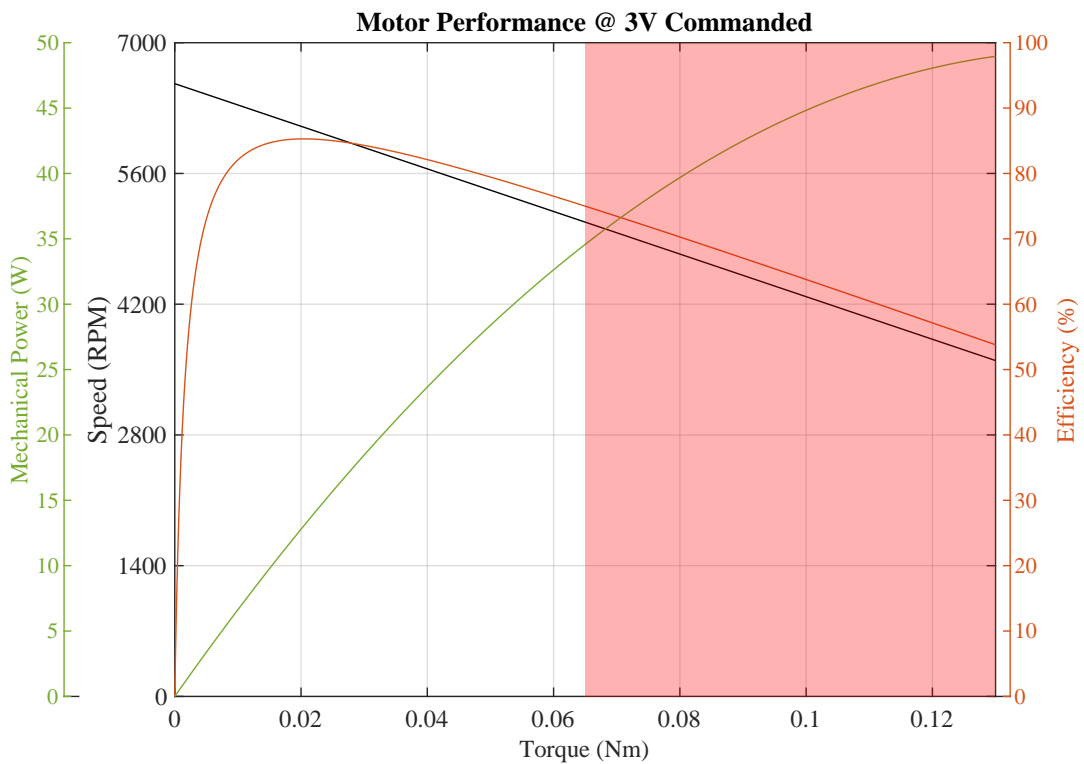
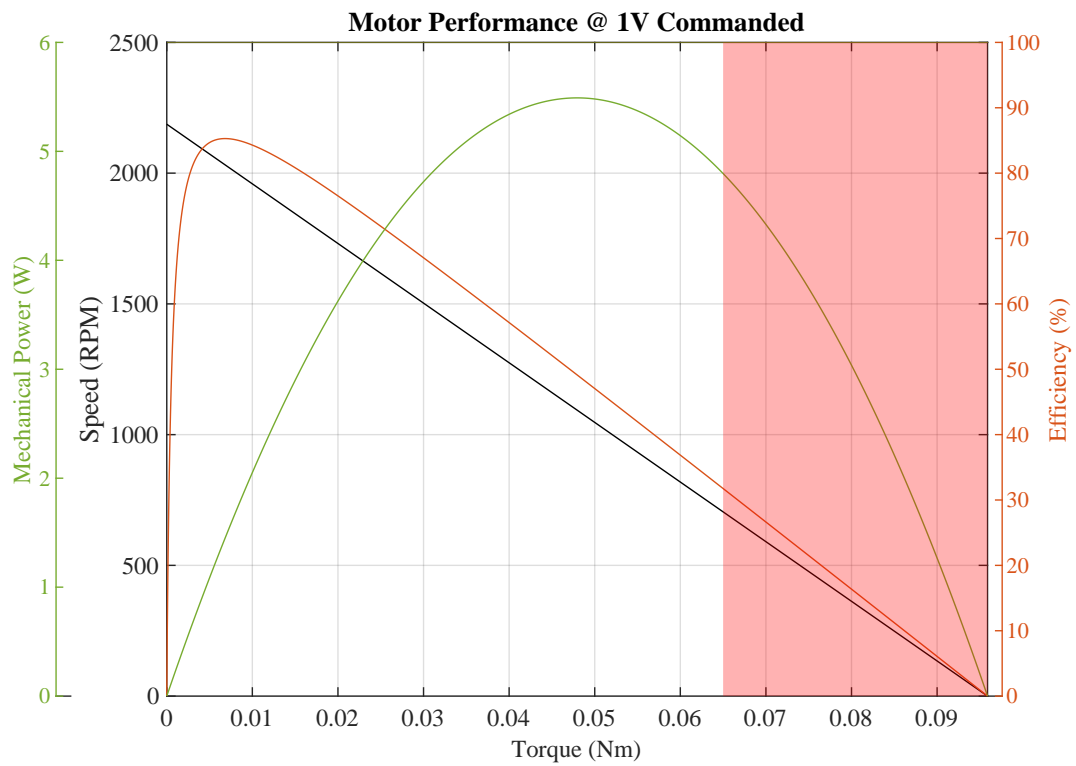

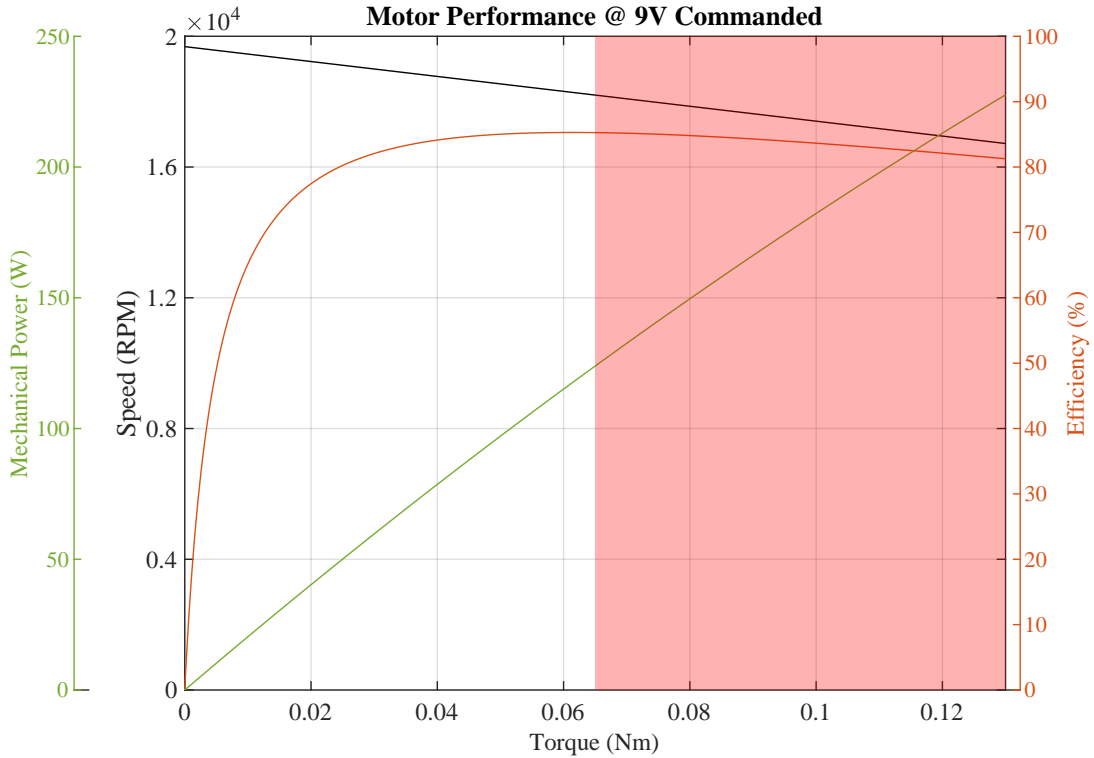
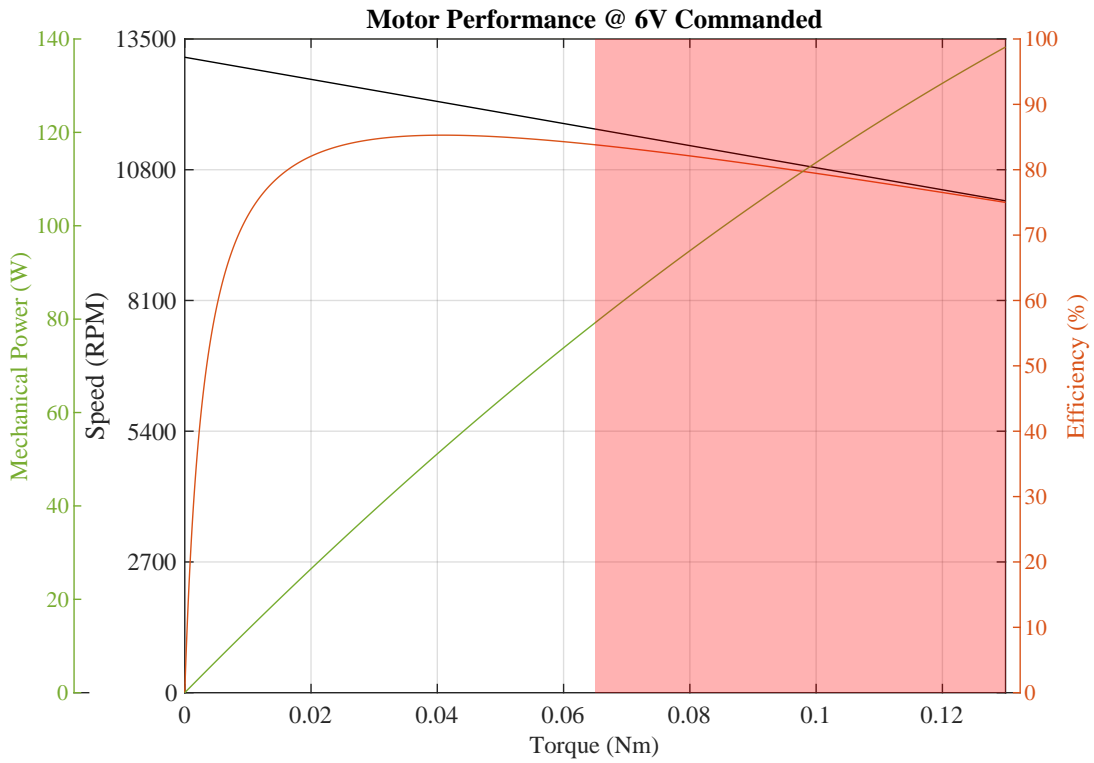

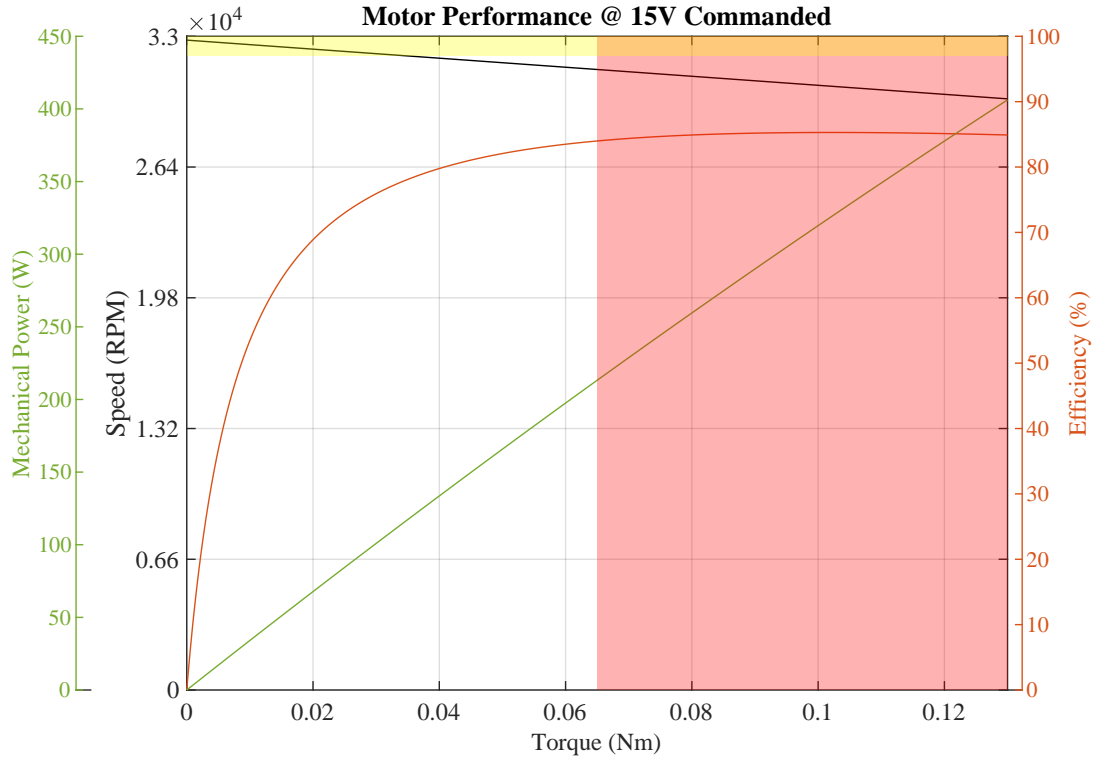
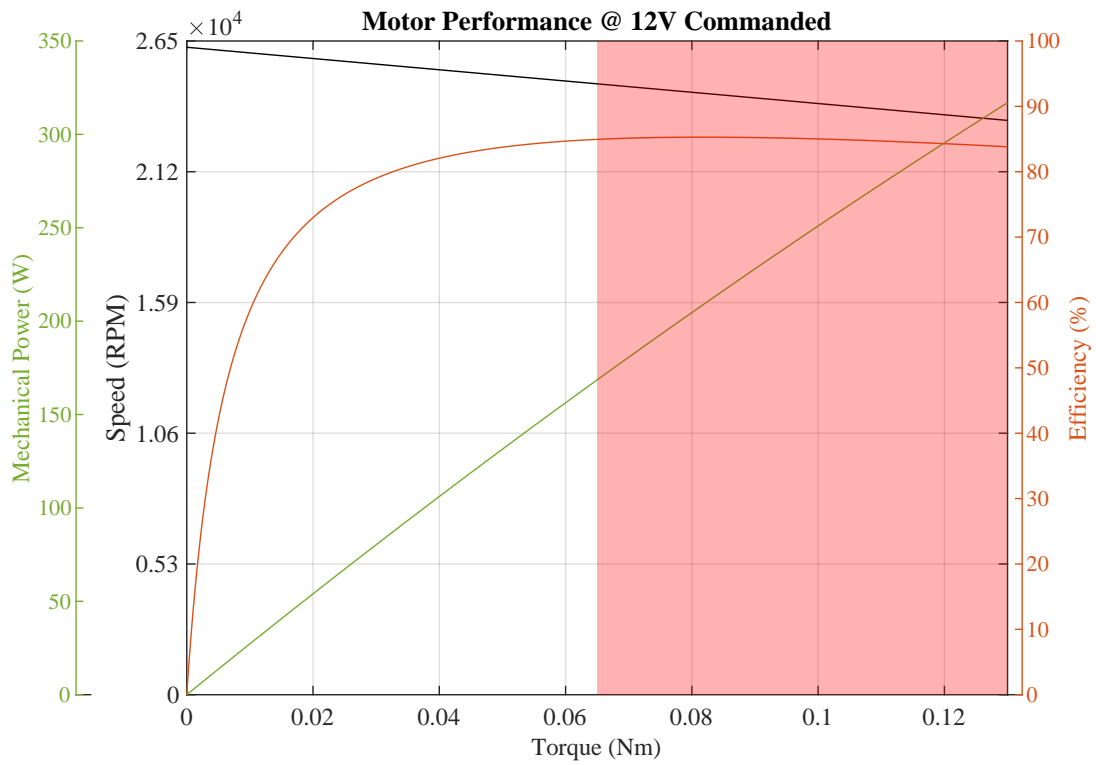

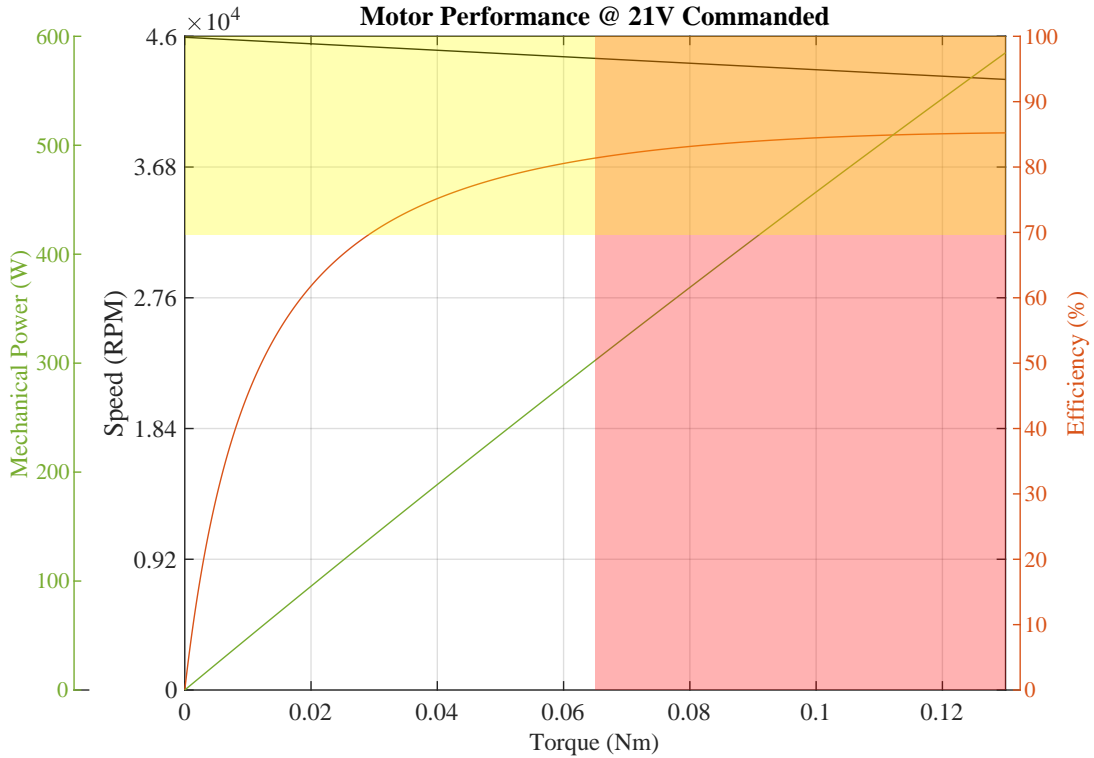
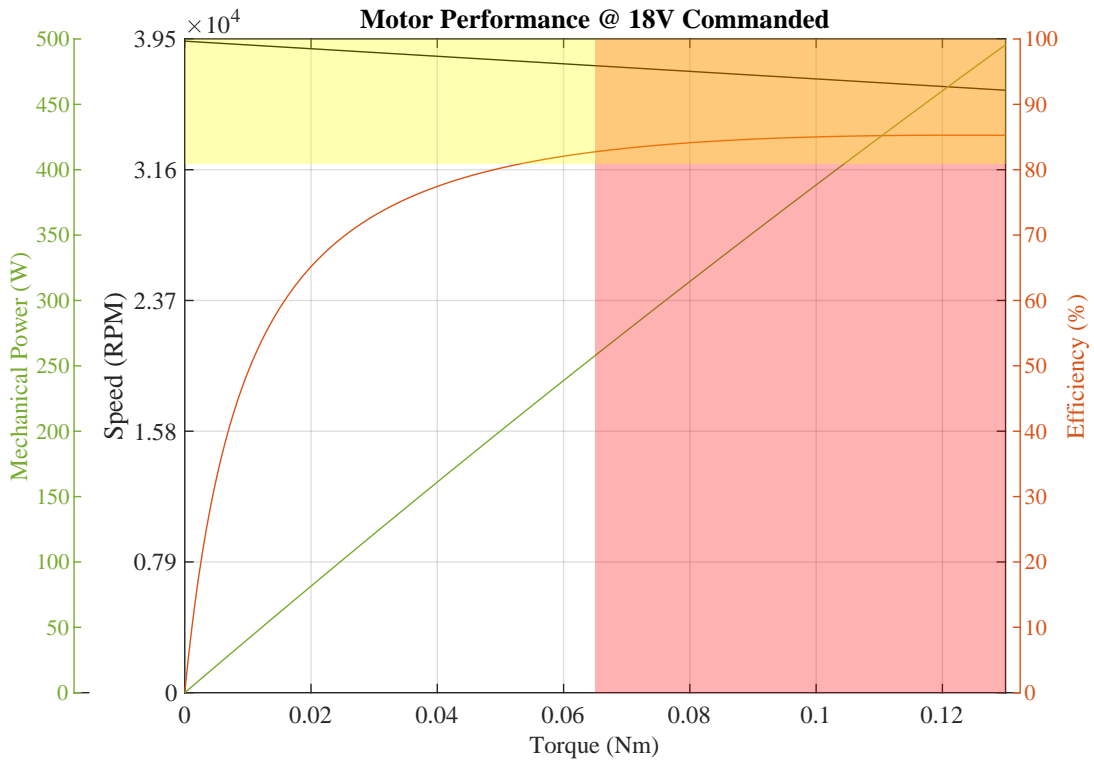



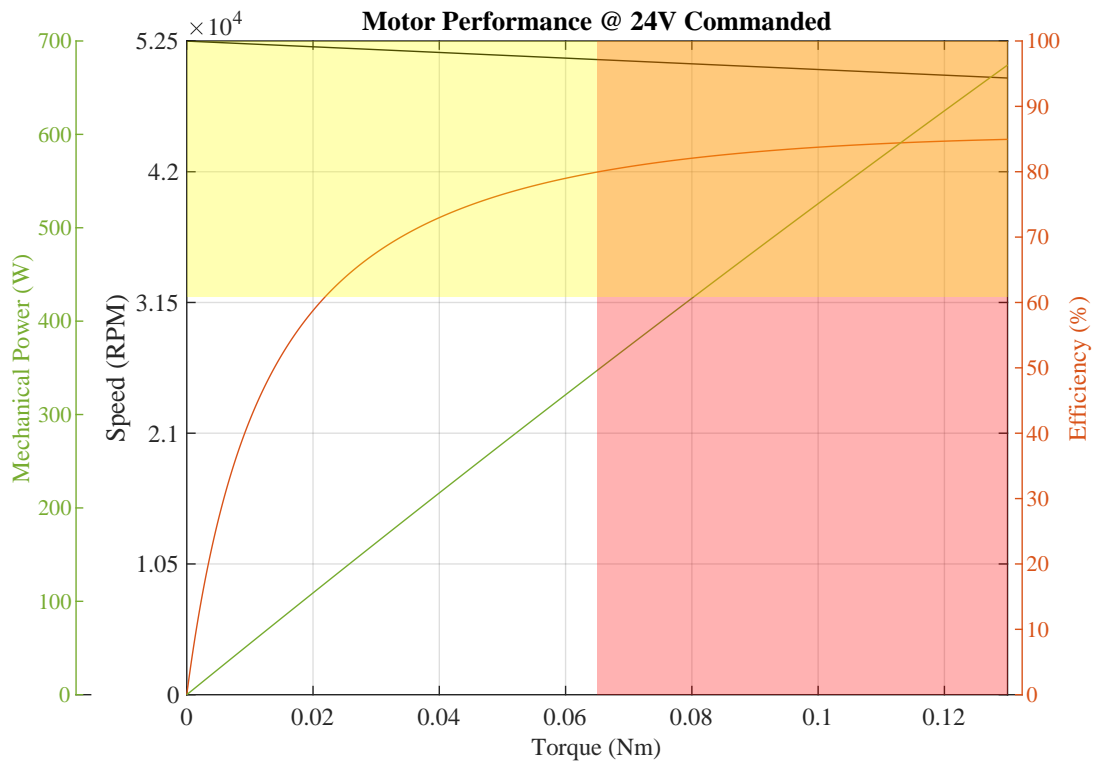

## X-ON Electronics

Largest Supplier of Electrical and Electronic Components

*Click to view similar products for [Multiple Function Sensor Modules](#) category:*

*Click to view products by [Crowd Supply](#) manufacturer:*

Other Similar products are found below :

[AD5T](#) [MM7150-AB1](#) [SIBA5-JRAB-DKL](#) [2314277-1](#) [2314277-2](#) [2314291-1](#) [ZMW-SENSOR-1](#) [2316851-1](#) [1-2314277-2](#) [2316852-1](#)  
[2331211-3](#) [2316852-2](#) [2316851-2](#) [1-2314277-1](#) [CS-125HSS-A](#) [eATVS-4](#) [eATVS-8](#) [tvLYT](#) [NGM\\_1](#) [SKU-7000](#) [DFR0759](#) [SG-Link-200](#)  
[SG-Link-200-OEM](#) [V-Link-200](#) [MNS2-9-IN-VM-005](#) [MNS2-9-W2-VD-DC](#) [MNS2-9-W2-VM-005](#) [K6PM-THMD-EIP](#) [K6PM-THS3232](#)  
[WYZBEE-SENS-101](#) [101020932](#) [101990693](#) [SIBA5-JRAB](#) [SIBA5-JREB](#) [SIBA5-JREB-DKL](#) [SIBA-JRA](#) [SIBA-JRAB](#) [SIBA-JRE](#) [SIBA-](#)  
[JREB](#) [SEK](#) [SCC30-DB Sample](#) [ESYS11X](#) [ESYS11X+LOPY915](#) [ESYS11X+LOPY868](#) [Sensit Discovery 3.1](#) [Sensit Discovery 3.2](#) [Sensit](#)  
[Discovery 3.3](#) [Sensit Discovery 3.4](#) [ZEPIR0BBS02MODG](#) [ZEPIR0BAS02MODG](#) [1-2314291-1](#)