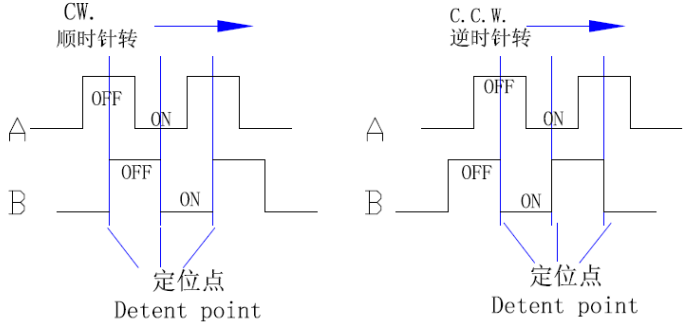
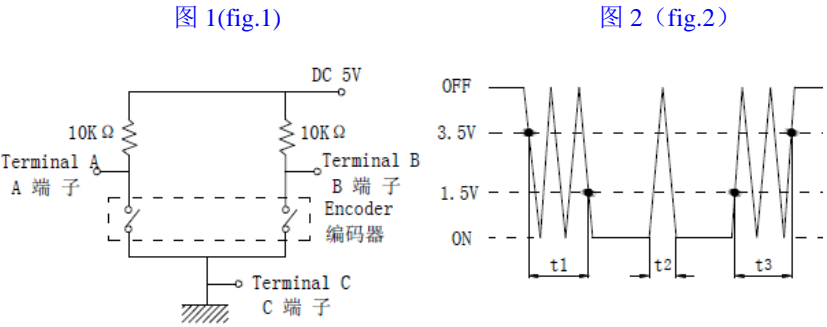

编码器规格书

ENCODER SPECIFICATIONS

1 一般事项 General information	
1-1 适用型号 Applicable models	ED089 系列 ED089 Serial
1-2 使用环境温度 Usage environment temperature	- 30℃ ~ + 70℃
1-3 保存环境温度 Storage environment temperature	- 40℃ ~ + 70℃
1-4 测试条件 Test condition	温度: 5~35℃, 湿度: 45~85%HR Temperature:5~35℃, Moisture:45~85%HR
1-5 环保要求 Environmental requisition	本产品符合 RoHS 指令 This product is compliant with RoHS Directive
1-6 耐焊接热 Soldering heat-resistance	<p>1、手工焊接温度最高 350℃ ± 5℃, 3 秒; 2、自动焊接温度最高 260℃ ± 5℃, 3 秒; 基板表面预热温度最高 100℃, 1 分钟以内; 3、以上过程均保证在 1 到 2 次; 4、不适用回流焊。</p> <p>1. Soldering iron Max ,350℃ ± 5℃ at 3 sec 2. Auto soldering 260℃ ± 5℃ max. at 3 Sec. Preheating temperature of board surface: 100℃ max. at within 1 minutes. 3. To guarantee the above process at 1 or 2 times. 4. No apply the reflow soldering.</p>
1-7 原产地 Country of origin	中国 China
2 构造 Construction	
2-1 外观 Appearance	各部件应完整, 无锈蚀、裂痕、电镀不良 Every part should finished, be not exist rust flaw crack and bad plating
2-2 寸法 Measurements	依照图面规定 Under conditions prescribed by design drawing.
3 机械性能 Mechanical characteristics	
3-1 全回转角度 Total rotational angle	360°
3-2 回转力矩 Rotational torque	50~350gf.cm (旋转速度: 60° /1 秒) 50~350gf.cm (Rotational velocity : 60° /1 Sec.)
3-3 定位数 Number of detent	20 个定位 20 Detents
3-4 切换角度 Change-Over angle	18° ± 3°
3-5 轴压引强度 Pull-Push Strength of Shaft	10Kgf.cm Min.
3-6 螺母锁紧强度 Nut tightening strength	10Kgf.cm Min.
3-7 轴摇晃度 Shaft wobble	在单个轴顶端施加压力 250gf, 轴径向偏移量小于: 1*轴长 L 尺寸/30mm On the tip of the single shaft exert pressure 250gf , Shaft radial deviant be smaller than: 1*shaft long L size/30mm
4 电气性能 Electrical characteristics	
4-1 额定电压 Voltage rating	DC 5V
4-2 额定电流 Current rating	1mA

4-3 耐电压 Voltage proof	AC 300V 1 分钟以上（端子和本体之间，端子和轴芯之间） 1 Minute at AC 300V (Between terminal – case, Between terminal –shaft).
4-4 最高使用电压 Maximum operating voltage	DC 10V 或 AC50V DC 10V or AC50V
4-5 最大使用电流 Maximum operating current	2.5mA
4-6 接触抵抗 Ratings power	10 Ω Max
4-7 绝缘抵抗 Insulation resistance	DC 250V 100MΩ 以上（端子和本体之间，端子和轴芯之间） 100MΩ min. At DC 250V (Between terminal – case, Between terminal –shaft).
4-8 脉冲数 Number of pulses	旋转一周（360°）输出 10 个脉冲 Output 10 pulses of rotate one circle(360°).
4-9 输出信号 Output signal	<p>A、B 信号，相位差的输出如下： * 备注：A 信号（A—COM 间），B 信号（B—COM 间） Output of phase difference, signals A and B, is as follows. *Remark: A signal (Between A-common) ,B signal (Between B-common)</p>  <p>The diagram shows two timing diagrams for CW (顺时针转) and C.C.W. (逆时针转) rotation. Each diagram shows two square wave signals, A and B, with a 90-degree phase shift. A vertical line indicates the 'Detent point' (定位点). The signals are labeled 'OFF' and 'ON' relative to a common terminal.</p>
4.10. 开关特性 Switching characteristics	<p>下图 1 (fig.1) 所示回路，轴以 360° /S 的速度转动测定 Measurement shall be made under the condition as follows. Shaft rotational speed: 360° /S test circuit. (fig.2)</p>  <p>图 1(fig.1) shows a test circuit with a DC 5V source, two 10KΩ resistors, and terminals A, B, and C. Terminal C is grounded. The encoder is connected between A and B.</p> <p>图 2 (fig.2) shows a timing diagram with voltage levels 3.5V (OFF) and 1.5V (ON). It illustrates the signal transitions at three points labeled t1, t2, and t3.</p> <p>(注) 编码 OFF 指输出电压 3.5V 以上的状态 (fig.2) Code –OFF area: The area which the voltage is 3.5V(fig.2) 编码 ON 指输出电压 1.5V 以下的状态。(fig.2) Code –ON area: The area which the voltage is 1.5V(fig.2)</p>
4.11.振荡 Chattering	<p>编码从 OFF-ON 或者 ON-OFF 时，输出 1.5V~3.5V 的通过时间，应符合规定。 Specified by the signal's passage time from 1.5V to 3.5V of each switching position (code OFF~ON or ON~OFF) (t1, t3≤3ms) fig.2</p>
4.12 滑动杂讯（突跳） Sliding noise (Bounce)	<p>编码 ON 部分的 1.5V 以上的电压变动时间在振荡 t1,t3 之间会产生 1ms 以上, 1.5V 以下的 ON 部分。另外，如果突跳 1.5V 以下的范围在 1ms 以上时，则判定为另一个突跳。 Specified by the time of voltage change exceeding 1.5V in code_ON area. When the bounce has code-ON time less than 1ms between chattering(t1or t3) the voltage change shall be regarded as a part of chattering. When the code-ON time between 2 bounces is less than 1ms. They are regarded as 1 linked bounce. (t2≤3ms) fig.2</p>

4-13 相位差
Phase difference

在没有定位的情况下 $T_d = T/4 \pm T/6$

* 备注: $T = \text{周期}$

In no detent circumstances $T_d = T/4 \pm T/6$ in case of no detent.

*Remark: $T = \text{Cycle}$

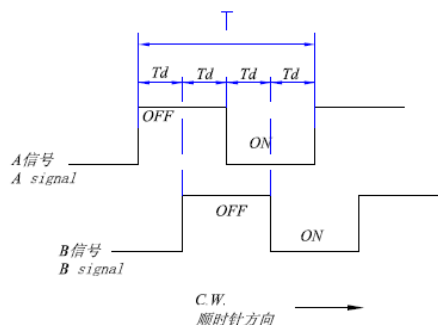

4-14.产品单体测试

(1)测试方法: 示波器探头分别夹在单体产品 VOL_A 脚和 VOL_B 脚上, 旋转旋钮, 测试 VOL_A, VOL_B 引脚输出的波形。(图 3 fig.3)

(2)判定方法: 开关是机械接触性编码器, 单体旋转过程中, 都会有毛刺(杂讯)产生, 波形 VOL_A、VOL_B 会出现多跳一个脉冲的情况, 此脉冲信号 t_1 、 t_2 、 $t_3 \leq 3\text{ms}$ (fig.2), 此现象属正常, 可以判定合格, 客户端在软件上用 R/C 滤波电路可以消除掉。图 4(fig.4)

图 3 (fig.3)



图 4 (fig.4)



4-15.软件方向识别

(1)A 相作为脉冲变化相, B 相作为方向判断相(即增减脉冲数的依据), 引脚 A 根据上升沿和下降沿判别, 引脚 B 根据高电平和低电平判别。

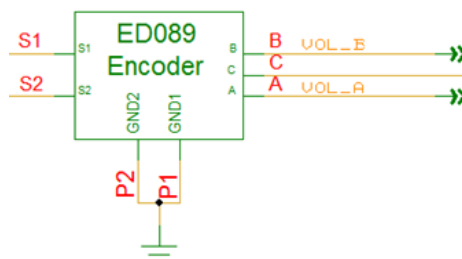
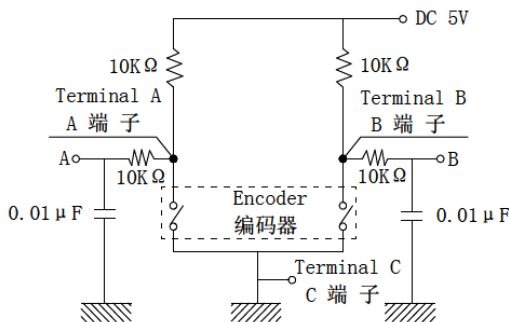
(2) 顺时针旋转时 (CW): A 脚 0-1 且 B 脚 0、A 脚 1-0 且 B 脚 1, 则为递增;

(3) 逆时针旋转时 (CCW): A 脚 0-1 且 B 脚 1、A 脚 1-0 且 B 脚 0, 则为递减;

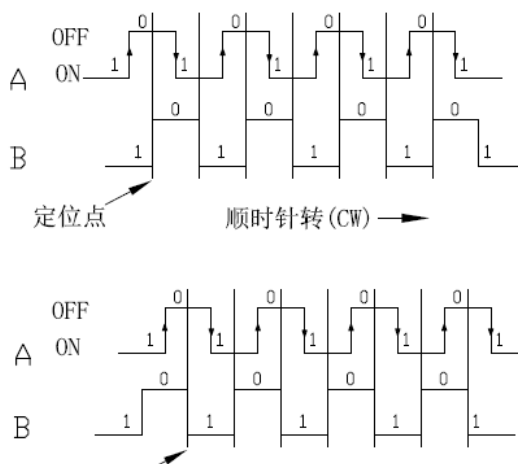

<p>4-16 回转寿命 Rotational life</p>	<p>无负荷情况下每小时旋转 600 周，寿命 30,000 周，寿命后： 1、绝缘抵抗 10MΩ 以上 DC250V（端子和本体之间，端子和轴芯之间）； 2、耐电压 AC100V 1 分钟（端子和本体之间，端子和轴芯之间），绝缘阻抗无击穿； 3、满足第 3-2 项、4-11 项、4-12 项 4、外观和结构无损坏。 30,000 cycles under no load circumstances by 600 r/h of rotation, afterlife cycle: 1. Insulation resistance:10MΩ min. At DC 250V. (Between terminal – case, Between terminal –shaft). 2. Withstanding voltage : AC 100V at 1 minute (Between terminal – case, Between terminal –shaft). No subversion on insulation resistance. 3. Content item No. 3-2、4-11、4-12. 4. No damage on appearance and structure.</p>			
<p>5 开关性能 Switch characteristics</p>				
<p> <input checked="" type="checkbox"/>适用 <input type="checkbox"/>不适用 Apply No apply </p>				
<p>5-1 开关型式 Switch type</p>	<p>按压式 Push type</p>			
<p>5-2 开关回路、 Switch configuration, Contact point</p>	<p>单刀单掷 S.P.S.T</p>			
<p>5-3 开关定格电力 Switch working angle</p>	<p>DC 16, 0.5A</p>			
<p>5-4 开关按压行程 Switch push travel</p>	<p>0.5+0.1/-0.2mm</p>			
<p>5-5 开关按压力 Switch push pressure</p>	<p>700±300gf</p>			
<p>5-6 开关接触电阻 Switch contact resistance</p>	<p>≤100mΩ，寿命后≤500mΩ ≤100mΩ，afterlife cycle: ≤500mΩ</p>			
<p>5-7 开关按压寿命 Operating life for momentary push switch</p>	<p>无负荷情况下每小时按压 600 次，寿命 20,000 次，寿命后： 1、耐电压 AC100V 1 分钟（开关端子和本体之间），绝缘阻抗无击穿； 2、开关按压力：满足第 5-5 项； 3、外观和结构无损坏。 20,000 cycles under no load circumstances by 600 r/h of push, afterlife cycle: 1. Withstanding voltage: AC 100V at 1 minute (Between switch terminal – case). No subversion on insulation resistance. 2. Switch push pressure: Content item No. 5-5. 3. No damage on appearance and structure.</p>			
<p>6 防水性能 Waterproof standard characteristics</p>				
<p>6-1 防水标准 Waterproof standard</p>	<p> <input type="checkbox"/> 不适用 No Apply <input checked="" type="checkbox"/> 七级防水 编码器轴芯轴套置于水中 1 米深处，其它部件密封后暴露在标准大气压中，30 分钟后电位器内部未进水。 Grade -7 of Waterproof standard Encoder's Shaft and Bush in water 1M deep, after other component sealed exposed to the standard atmosphere, after 30 minutes no water into the Encoder's inner. </p>			
<p style="text-align: center;"> 东莞市长泰尔电子有限公司 DONG GUAN CHANG TAI ER ELECTRONIC CO., LTD. </p>		<p style="text-align: center;">制作 Designed By</p>	<p style="text-align: center;">审核 Checked By</p>	<p style="text-align: center;">核准 Approved By</p>

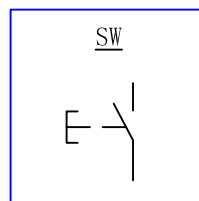
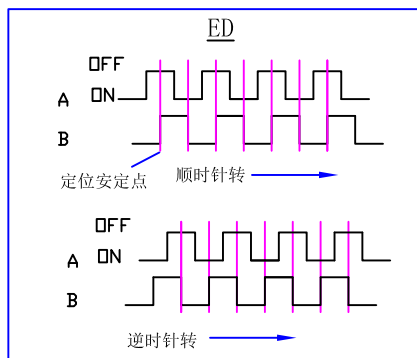
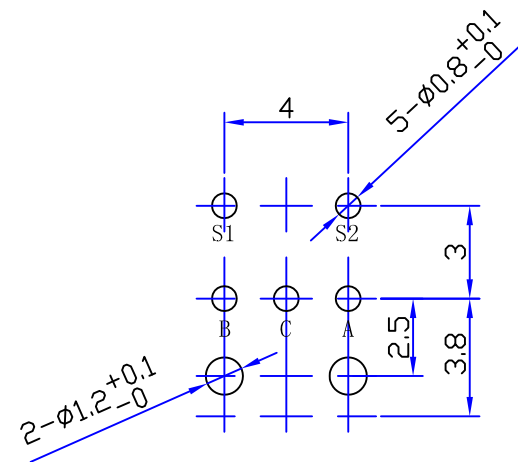
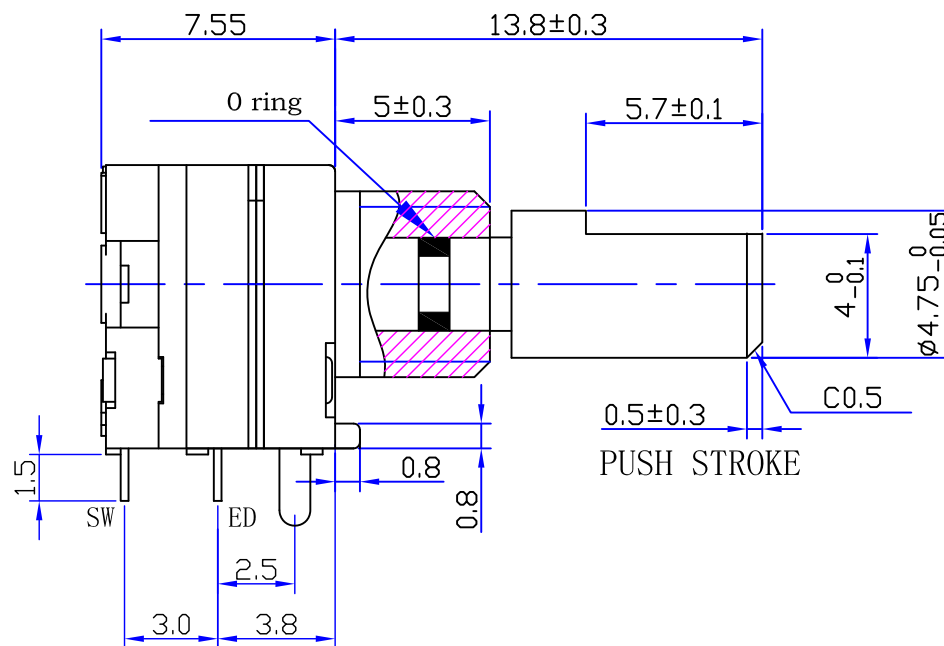
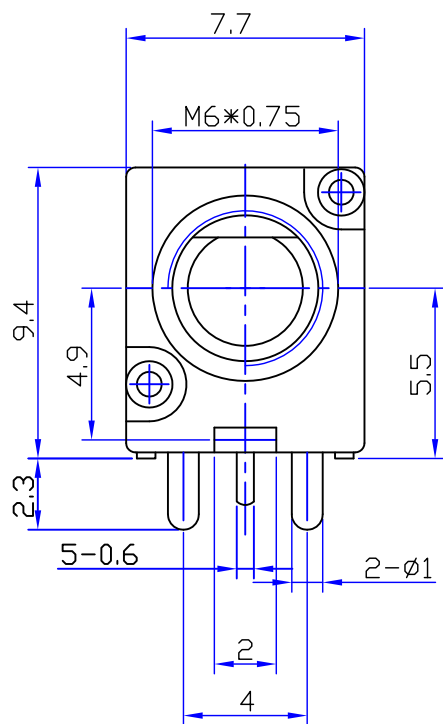
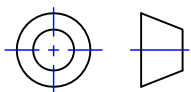

东莞市长泰尔电子有限公司

未注尺寸公差	
L ≤ 1.0时	±0.1
1.0 < L ≤ 10时	±0.3
10 < L ≤ 30时	±0.5
30 < L ≤ 100时	±1.0

比例	4:1	版本	1.0	单位	mm	设计	审核	批准
品名	ED0890DM安装尺寸图							
图号	ED0890DM-FE13.8S5.8							

1、产地及生产时间

Marking detail

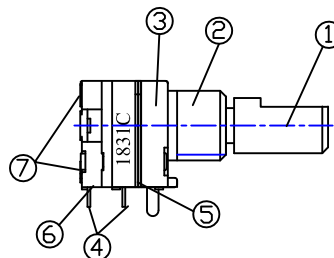

18 3 1 C

产地: C (中国)
Country of origin: C (China)

WEEK CODE: 1 (1st Week)、2 (2nd Week)、3 (3rd Week)、4 (4th Week)、5 (5th Week)

月份: 1 (1月)、2 (2月)、... O(10月)、N (11月)、D (12月)
Month code: 1 (Jan.)、2 (Feb.)、... O(Oct.)、N (Nov.)、D (Dec.)

年
Year Code: 11 (2011)、12 (2012)、13 (2013)、... 18 (2018)、19 (2019)、20 (2020)

2、材质

Materials

序号 No.	部件名称 Component Part Name	材质 Material quality	数量 QTY	颜色 Color	供应商 Supplier	S G S
1	轴芯 Shaft	不锈钢<SUS303> Stainless steel<SUS303>	1	灰色 Gray	中国 China	
2	轴套 Bushing	不锈钢<17-4P> Stainless steel<17-4P>	1	灰色 Gray	中国 China	
3	基片塑料壳 Carbon plastic shell	PA66-G15	1	蓝色 Blue	中国 China	
4	端子 Terminal	磷铜镀银 Copper	1	银白色 Silvery white	中国 China	
5	隔板 Partition	不锈钢 Stainless steel	1	灰色 Gray	中国 China	
6	开关本体 SWITCH BODY	PA66+G15	1	白色 white	中国 CHINA	
7	铆钉 Rivet	紫铜镀镍 Red copper plate Nickel	2	银白色 Silvery white	中国 China	

东莞市长泰尔电子有限公司
DONG GUAN CHANG TAI ER ELECTRONICS CO.,LTD.

版本 Edition	1.0	设计 Designed By	审核 Checked By	批准 Approved By
品名 Type Name	ED0890DM			
图号 Dwg. NO.	ED0890DM-FE13. 8S5. 8-C10-2030			

外箱:
Outer carton box:
1箱放30扎
A box put 30 Inner carton box

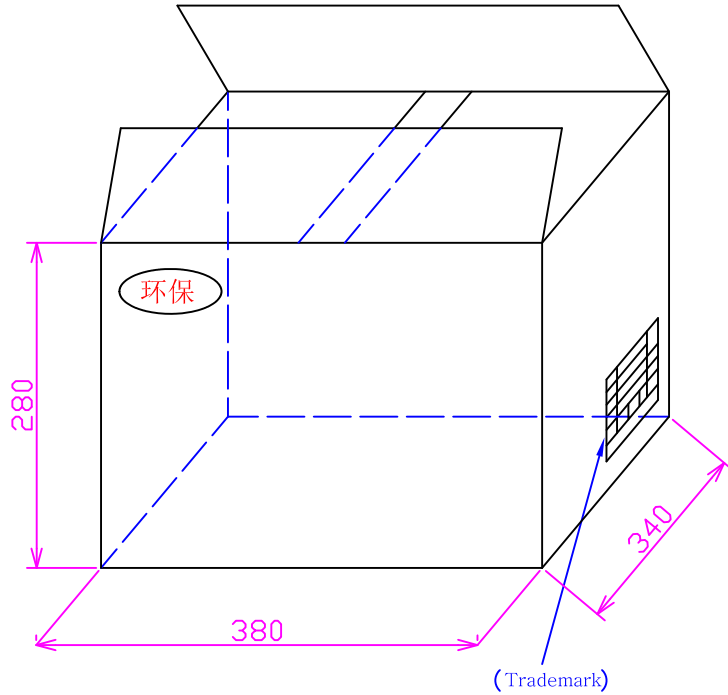

(Trademark)

装箱单				
Customer 客户名称				RoHS 符合
Model No 客户料号				
Type 型号规格			C / NO 订单号码	
Q.T.Y 数量			Date 日期	
Boxing No 箱号	Total Boxing QTY 总箱数		QC 检验	
DONG GUAN CHANG TAI ER ELECTRONICS CO.,LTD 东莞市长泰尔有限公司				

包装条:
Inner carton box:
1扎捆20条
A box put 20 layer box

(Trademark)

SUPPLIER 供应商			环保
ITEM CODE 料号			
TYPE 型号			
QTY 数量	DATE 日期		
LOTNO 批号			

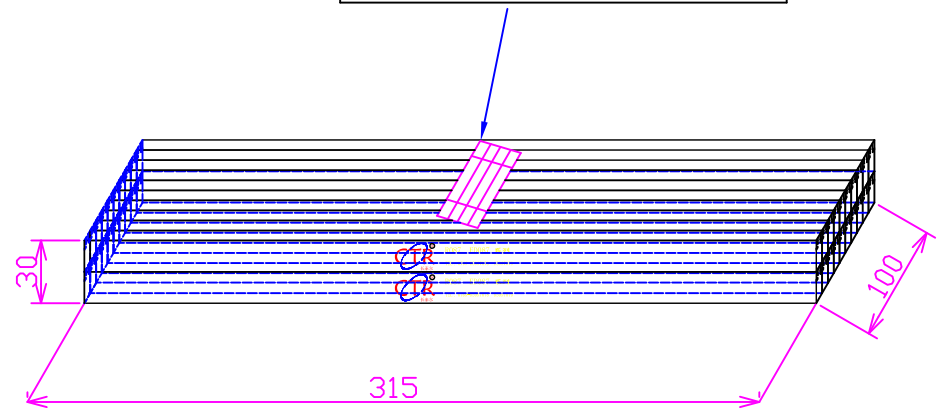

包装条:
Box:
1条放10PCS产品
A box put 10 pcs



东莞市长泰尔电子有限公司 DONG GUAN CHANG TAI ER ELECTRONICS CO., LTD						
单位 Unit	毫米 mm	版本 Edition	1.0	设计 Designed By	审核 Checked By	批准 Approved By
品名 Type Name	ED0890DM-包装 ED0890DM- Packing					
图号 Dwg.NO.	ED0890DM-13.8S5.8					

X-ON Electronics

Largest Supplier of Electrical and Electronic Components

Click to view similar products for [Coded Rotary Switches](#) category:

Click to view products by [CTR](#) manufacturer:

Other Similar products are found below :

[PT65503RT](#) [Y36D02243FPLFT](#) [RTAP31S12WFLSP](#) [MADR-16H1](#) [GSER-10](#) [6KF001B-3S10R4-0](#) [EC11E153442W](#) [EC11E1534441](#) [SC-2110](#) [SD-2010TB](#) [MER-16H](#) [EDR-08](#) [USR-10](#) [FSR-08](#) [FSR-04S](#) [ESR-16](#) [HAMR-10S](#) [SDR-10H](#) [QSR-16H](#) [HAMR-16](#) [FDR-04S](#) [EDR-16S](#) [ESR-10S](#) [QDR-08H1](#) [TDR-04](#) [EDR-08S](#) [ESR-16H](#) [QDR-10](#) [EDR-10S](#) [QSR-06S](#) [ESR-08S](#) [EC11E156040N](#) [EC11B15243DC](#) [EC35AH220501](#) [EC18AGB20406](#) [EC11E09244C3](#) [EC11G1534414](#) [EC11E156T402](#) [EC60A1520405](#) [EC11E1564454](#) [EC11J0925501](#) [EC11E15204B1](#) [EC11E1564439](#) [EC50A0920403](#) [ED103180-FE14.5S7.5-A16-1010](#) [ED08E42S-FE15C7.0-A16-1020](#) [ED08C030-FE18C9.0-A16-1002X](#) [ED08C210-FE18A6.0-A16-1002](#) [ED08C110-FE18S9.0-A16-1040](#) [ED08C150-BM20S6.0-A16-1026](#)