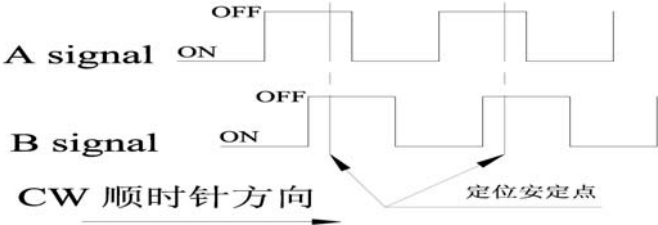
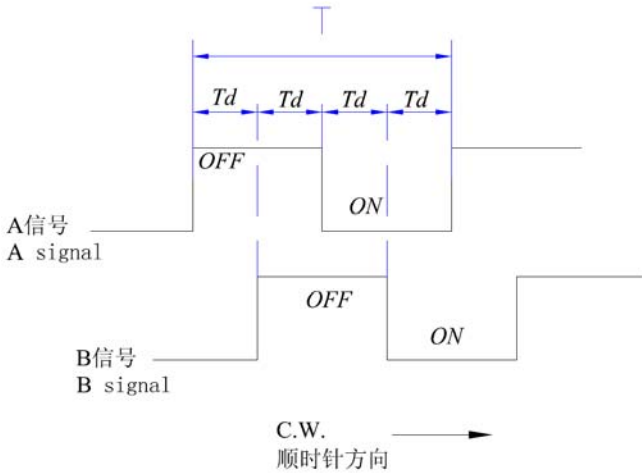

编码器规格书

ENCODER SPECIFICATIONS

1 一般事项 General information	
1-1 适用型号 Applicable models	ED11302O-FB15S7.0-C12-0005
1-2 使用环境温度 Usage environment temperature	- 30℃ ~ + 80℃
1-3 保存环境温度 Storage environment temperature	- 40℃ ~ + 85℃
1-4 测试条件 Test condition	温度: 5~35℃, 湿度: 45~85%HR Temperature: 5~35℃, Moisture: 45~85%HR
1-5 环保要求 Environmental requisition	本产品符合 RoHS 指令 This product is compliant with RoHS Directive
1-6 耐焊接热 Soldering heat-resistance	1、手工焊接温度最高 350℃ ± 5℃, 3 秒; 2、自动焊接温度最高 260℃ ± 5℃, 3 秒; 基板表面预热温度最高 100℃, 1 分钟以内; 3、以上过程均保证在 1 到 2 次; 4、不适用回流焊。 1. Soldering iron Max ,350℃ ± 5℃ at 3 sec 2. Auto soldering 260℃ ± 5℃ max. at 3 Sec. Preheating temperature of board surface: 100℃ max. at within 1 minutes. 3. To guarantee the above process at 1 or 2 times. 4. No apply the reflow soldering.
1-7 原产地 Country of origin	中国 China
2 构造 Construction	
2-1 外观 Appearance	各部件应完整, 无锈蚀、裂痕、电镀不良 Every part should finished, be not exist rust flaw crack and bad plating
2-2 寸法 Measurements	依照图面规定 Under conditions prescribed by design drawing.
3 机械性能 Mechanical characteristics	
3-1 全回转角度 Total rotational angle	360°
3-2 回转力矩 Rotational torque	80~200gf.cm (旋转速度: 60° /1 秒) 80~200gf.cm (Rotational velocity : 60° /1 Sec.)
3-3 定位数 Number of detent	■ <u>12</u>
3-4 轴压引强度 Pull-Push Strength of Shaft	10Kgf.cm Min.
3-5 螺母锁紧强度 Nut tightening strength	10Kgf.cm Min.
3-6 轴摇晃度 Shaft wobble	在距离轴顶端 5mm 处, 沿径向瞬间施加 500gf.cm 力的测试; 轴径向偏移量小于: 0.7*轴长 L 尺寸/30mm A momentary load of 500gf.cm should be applied at the point 5mm from the tip of the shaft in a direction perpendicular to the axis of shaft; Shaft radial deviant be smaller than: 0.7*shaft long L size/30mm

4 电气性能 Electrical characteristics	
4-1 额定电压 Voltage rating	DC 5V
4-2 额定电流 Current rating	2.5mA
4-3 耐电压 Voltage proof	AC 300V 1 分钟以上 (端子和本体之间, 端子和轴芯之间) 1 Minute at AC 300V (Between terminal – case, Between terminal –shaft).
4-4 绝缘抵抗 Insulation resistance	DC 250V 100MΩ 以上 (端子和本体之间, 端子和轴芯之间) 100MΩ min. At DC 250V (Between terminal – case, Between terminal –shaft).
4-5 脉冲数 Number of pulses	■ <u>12</u> 旋转一周 (360°) 输出的总脉冲数 Output total pulses of rotate one circle(360°).
4-6 输出信号 Output signals	A、B 信号相位差输出波形如下: * 备注: A 信号 (A-COM 间), B 信号 (B-COM 间) Output signals A and B of phase difference wave form as below. *Remark: A signal (Between A-common) ,B signal (Between B-common) SW1: 12P12定位波形图: 代码C 
4-7 相位差 Phase difference	在没有定位的情况下 $T_d=T/4 \pm T/6$ * 备注: T=周期 In no detent circumstances $T_d=T/4 \pm T/6$ in case of no detent. *Remark: T= Cycle 
4-8 回转寿命 Rotational life	无负荷情况下每小时旋转 600 周, 寿命 30,000 周, 寿命后: 1、绝缘抵抗 10MΩ 以上 DC250V (端子和本体之间, 端子和轴芯之间); 2、耐电压 AC100V 1 分钟 (端子和本体之间, 端子和轴芯之间), 绝缘阻抗无击穿; 3、回转力矩: 满足第 3-2 项; 4、外观和结构无损坏。 30,000 cycles under no load circumstances by 600 r/h of rotation, afterlife cycle: 1. Insulation resistance:10MΩ min. At DC 250V. (Between terminal – case, Between terminal –shaft). 2. Withstanding voltage : AC 100V at 1 minute (Between terminal – case, Between terminal –shaft). No subversion on insulation resistance. 3. Rotational torque : Content item No. 3-2. 4. No damage on appearance and structure.

<p>4-9 耐湿性 Damp heat</p>	<p>温度 $40 \pm 2^{\circ}\text{C}$, 湿度 90-95% 的恒温恒湿槽中放置 96 ± 4 小时, 在常温、常湿中放置 1.5 小时后测试.</p> <p>所有项目应满足初期规格.</p> <p>The encoder shall be stored at temperature of $40^{\circ}\text{C} \pm 2^{\circ}\text{C}$ with relative humidity of 90% to 95% for $96 \pm 4\text{H}$ in a thermostatic chamber . And the encoder shall be subjected to standard atmospheric conditions for 1.5H , After which measurements shall be made.</p> <p>Specifications in clause all items is shall be satisfied.</p>
<p>4-10 耐热性 Dry heat</p>	<p>温度 $85 \pm 3^{\circ}\text{C}$ 的恒温箱中放置 96 ± 4 小时; 在常温、常湿中放置 1.5 小时后测试.</p> <p>所有项目应满足初期规格.</p> <p>The encoder shall be stored at a temperature of $85 \pm 3^{\circ}\text{C}$ for $96 \pm 4\text{H}$ in a thermostatic chamber . And the encoder shall be subjected to standard atmospheric conditions for 1.5H , After which measurements shall be made.</p> <p>Specifications in clause all items is shall be satisfied.</p>
<p>4-11 低温特性 Cold</p>	<p>温度 $-40 \pm 3^{\circ}\text{C}$ 的恒温箱中放置 96 ± 4 小时; 在常温、常湿中放置 1.5 小时后测试.</p> <p>所有项目应满足初期规格.</p> <p>The encoder shall be stored at a temperature of $-40 \pm 3^{\circ}\text{C}$ for $96 \pm 4\text{H}$ in a thermostatic chamber . And the encoder shall be subjected to standard atmospheric conditions for 1.5H , After which measurements shall be made.</p> <p>Specifications in clause all items is shall be satisfied.</p>

5 开关的性能 Switch characteristics				
<input type="checkbox"/> 适用 <input checked="" type="checkbox"/> 不适用 Apply No apply				
5-1 开关型式 Switch type	按压式 Push type,			
5-2 开关回路 Switch circuit	单刀单掷 S.P.S.T			
5-3 开关定格电力 Switch working angle	DC 5V, 10mA			
5-4 开关按压行程 Switch push travel	0.5 ± 0.2 mm			
5-5 开关按压力 Switch push pressure	1200 ± 400 gf			
5-6 开关接触电阻 Switch contact resistance	$\leq 100\text{m}\Omega$, 寿命后: $\leq 200\text{m}\Omega$ $\leq 100\text{m}\Omega$, after life cycle: $\leq 200\text{m}\Omega$			
5-7 开关按压寿命 Operating life for momentary push switch	无负荷情况下每小时按压 600 次, 寿命 20,000 次, 寿命后: 1、耐电压 AC100V 1 分钟 (开关端子和本体之间), 绝缘阻抗无击穿; 2、开关按压力: 满足第 5-5 项; 3、外观和结构无损坏。 20,000 cycles under no load circumstances by 600 r/h of push, afterlife cycle: 1. Withstanding voltage: AC 100V at 1 minute (Between switch terminal – case). No subversion on insulation resistance. 2. Switch push pressure: Content item No. 5-5. 3. No damage on appearance and structure.			
6 防水性能 Waterproof standard characteristics				
6-1 防水标准 Waterproof standard	<input type="checkbox"/> 不适用 No Apply <input checked="" type="checkbox"/> 七级防水 编码器轴芯轴套置于水中 1 米深处, 其它部件密封后暴露在标准大气压中, 30 分钟后电位器内部未进水。 Grade -7 of Waterproof standard Encoder's Shaft and Bush in water 1M deep, after other component sealed exposed to the standard atmosphere, after 30 minutes no water into the Encoder's inner.			
东莞市长泰尔电子有限公司 DONG GUAN CHANG TAI ER ELECTRONIC CO., LTD.		制作 Designed By	审核 Checked By	核准 Approved By

16 15 14 13 12 11 10 9 8 7 6 5 4 3 2 1

L
K
J
I
H
G
F
E
D
C
B
A

L
K
J
I
H
G
F
E
D
C
B
A

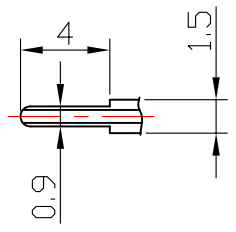
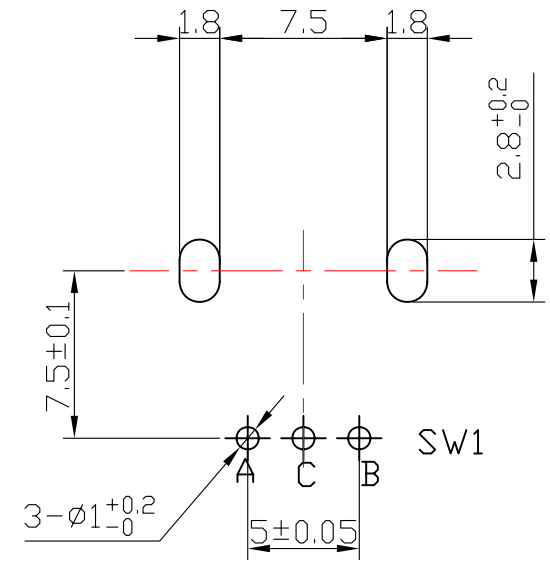
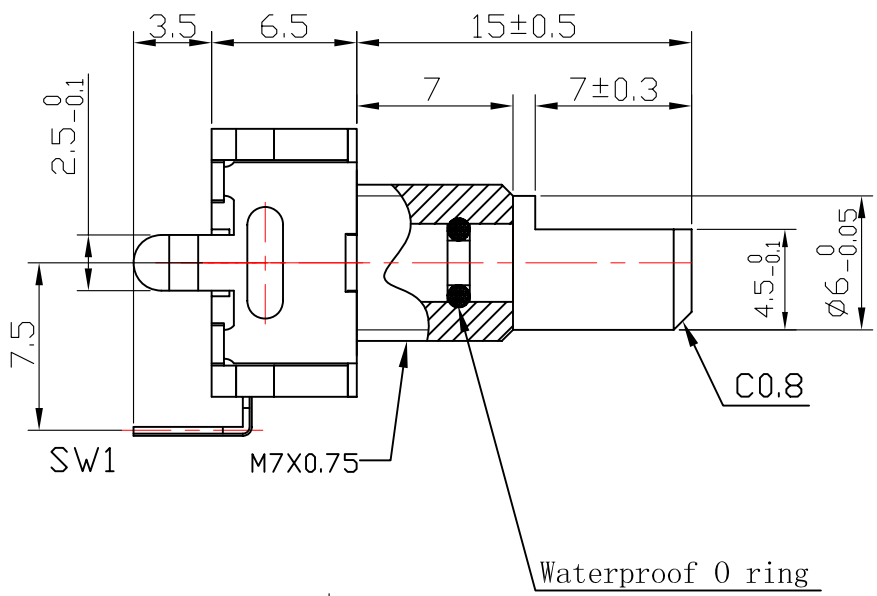
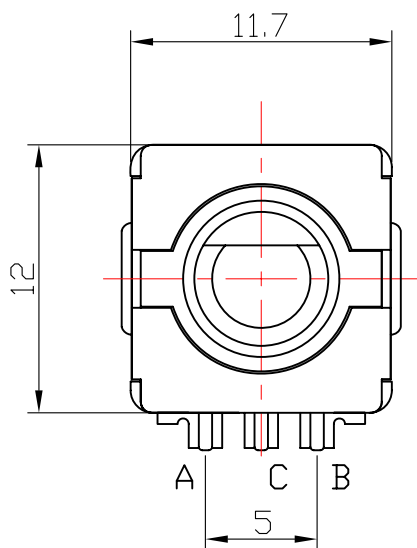

P. C. B MOUNTING DETAIL

▽			
▽			
▽			
▽			
标记	变更内容	改图	日期

SW1: 12P12定位波形图: 代码C

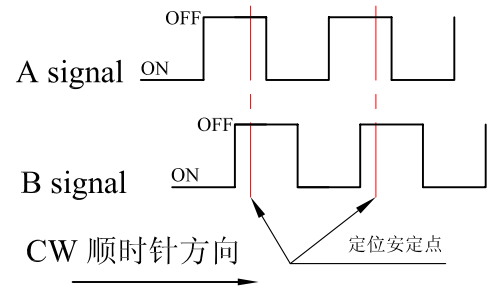

未注尺寸公差		东莞市长泰尔电子有限公司					
L ≤ 1.0时 ±0.1		视角	45°	制图	谢敏	出图日	2019-12-09
1.0 < L ≤ 10时 ±0.3		比例	3:1	单位	mm		
10 < L ≤ 30时 ±0.5		版本	1.0	设计		审核	批准
30 < L ≤ 100时 ±1.0		品名		ED113020安装尺寸图			
		图号		ED113020-FB15S7.0-C12-0005			

16 15 14 13 12 11 10 9 8 7 6 5 4 3 2 1

X-ON Electronics

Largest Supplier of Electrical and Electronic Components

Click to view similar products for [Coded Rotary Switches](#) category:

Click to view products by [CTR](#) manufacturer:

Other Similar products are found below :

[PT65503RT](#) [Y36D02243FPLFT](#) [RTAP31S12WFLSP](#) [MADR-16H1](#) [GSER-10](#) [6KF001B-3S10R4-0](#) [EC11E153442W](#) [EC11E1534441](#) [SC-2110](#) [SD-2010TB](#) [MER-16H](#) [EDR-08](#) [USR-10](#) [FSR-08](#) [FSR-04S](#) [ESR-16](#) [HAMR-10S](#) [SDR-10H](#) [QSR-16H](#) [HAMR-16](#) [FDR-04S](#) [EDR-16S](#) [ESR-10S](#) [QDR-08H1](#) [TDR-04](#) [EDR-08S](#) [ESR-16H](#) [QDR-10](#) [EDR-10S](#) [QSR-06S](#) [ESR-08S](#) [EC11E156040N](#) [EC11B15243DC](#) [EC35AH220501](#) [EC18AGB20406](#) [EC11E09244C3](#) [EC11G1534414](#) [EC11E156T402](#) [EC60A1520405](#) [EC11E1564454](#) [EC11J0925501](#) [EC11E15204B1](#) [EC11E1564439](#) [EC50A0920403](#) [ED103180-FE14.5S7.5-A16-1010](#) [ED08E42S-FE15C7.0-A16-1020](#) [ED08C030-FE18C9.0-A16-1002X](#) [ED08C210-FE18A6.0-A16-1002](#) [ED08C110-FE18S9.0-A16-1040](#) [ED08C150-BM20S6.0-A16-1026](#)