

## EMI/RFI Surface Mount $\pi$ & C Filters for SMT Applications

### APPLICATION

**TUSONIX 4700/4701 Series  $\pi$  Filters & 4702 Series C Filters** are used where cost and space savings have priority and improved insertion loss is required.

TUSONIX' unique design makes the filter suitable for common production soldering processes.

TUSONIX' state-of-the-art manufacturing process results in excellent electrical and mechanical performance. The square or round body allows easy handling, positioning and soldering onto the PCB. This is another cost effective quality product from TUSONIX.

### FEATURES

- **Excellent Performance**
- **Easy Placement**
- **Excellent Solderability**
- **Reduces PCB Component Count**

### EMI/RFI Filter Specifications

#### 1.0 Scope

This specification describes the basic performance requirements of the TUSONIX EMI/RFI surface mount Filters.

#### 2.0 Capacitance

2.1 Measurement Conditions: Capacitance measured at  $25^{\circ}\pm 2^{\circ}\text{C}$ , 50% max R.H. and Frequency of 1 KHz @  $1\pm 0.2\text{VRMS}$ .

2.2 Capacitance Tolerance: Listed capacitances are minimum value at  $25^{\circ}\pm 2^{\circ}\text{C}$  unless otherwise specified.

#### 3.0 Insertion Loss

3.1 Measurement Conditions: Attenuations listed are measured in a  $50\Omega$  system at  $25^{\circ}\pm 2^{\circ}\text{C}$  under no-load conditions (per MIL-STD-220).

3.2 Insertion Loss Tolerance: The attenuations listed are typical values under indicated conditions.

3.3 Listed insertion loss data is a measurement of filter performance in a matched  $50\Omega$  system. It is highly recommended that filter performance be verified under actual circuit operation conditions.

#### 4.0 Operating Conditions

Filters are designed to operate continuously at the temperature, voltage and current stated for each TUSONIX part number. Operating temperature ranges are from  $-55^{\circ}\text{C}$  to either  $85^{\circ}\text{C}$  or  $125^{\circ}\text{C}$ .

#### 5.0 Dielectric Withstanding Voltage

Filters shall withstand three times the DC working voltage applied between either terminal and ground electrode.

#### 6.0 Insulation Resistance

Measured at  $25^{\circ}\pm 2^{\circ}\text{C}$  with 100Vdc and charging current limited to 50mA max. The IR after two minutes maximum shall be a minimum of 10,000 Megohms.

#### 7.0 Packaging

Tape and reeled for auto placement.

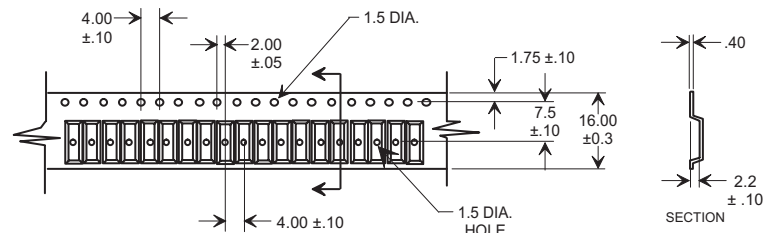
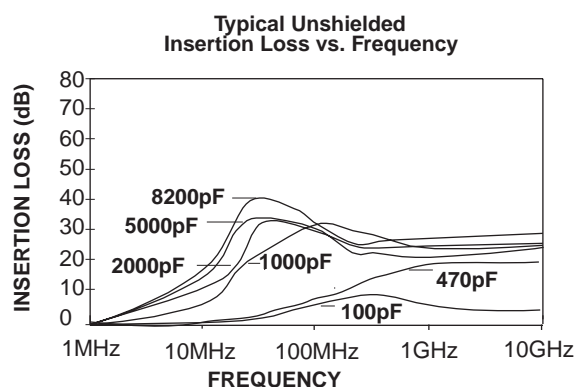
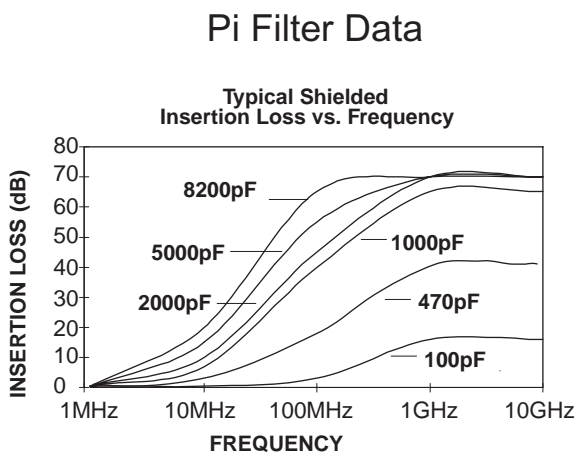

NOTES:

REFERENCE IEC-286-3 TYPE II AND EIA-481-A  
TAPING OF SURFACE MOUNT COMPONENTS  
FOR AUTOMATIC PLACEMENT

## EMI/RFI Surface Mount $\pi$ & C Filters for SMT Applications

### 4700 & 4702 SERIES

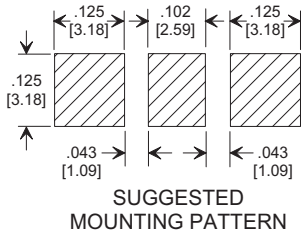
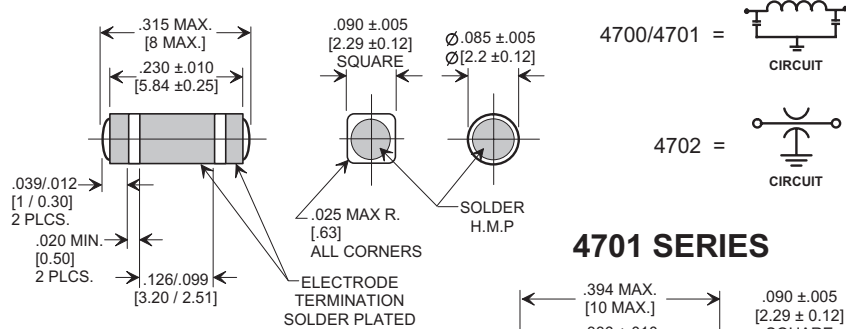

Dielectric Withstanding - 300VDC  
 Direct Current Rating - 10 ADC  
 Inductance Value - 100nH Minimum

**Please note:** Additional Capacitance Values and Mounting Patterns are available upon request.

### 4701 SERIES

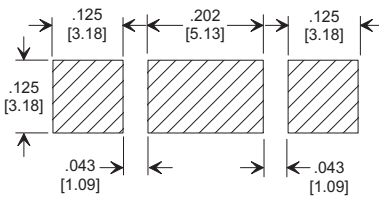
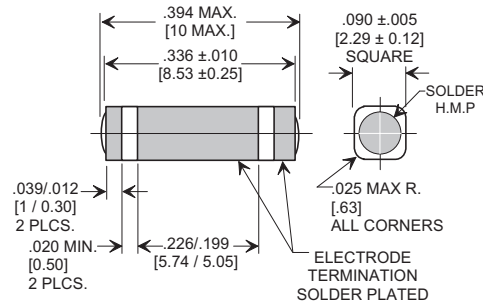

SUGGESTED MOUNTING PATTERN  
 ▶ Denotes "C" type filters - 20 Adc

### Product Installation Recommendations for Surface Mount $\pi$ & C Filters

#### Soldering Notes:

Surface Mount  $\pi$  & C Filters may be soldered to Printed Circuit Boards and substrates in a variety of methods: solder wave, hot air, oven soldering, vapor phase reflow, infrared soldering or immersion soldering.

Ceramic Components require careful soldering techniques to avoid the possible effects of thermal shock. These effects can be minimized by using a preheat process prior to soldering. Both time and temperature are important in the preheat cycle.

When using soldering irons, it is very important that the solder iron tip does not touch the ceramic body. The iron should be applied only to the termination solder fillet. The temperature of the soldering tip should be controlled to 500°F (260°C) max. Soldering should be achievable in 2-3 seconds. Recommended solder composition is 60% tin and 40% lead.

Failure to follow proper preheat and solder practices can result in thermal shock to the ceramic body which may be manifested as:

- Micro cracks in the ceramic body
- Electrical shorts
- Insulation resistance degradation in accelerated life test conditions.

All Surface Mount  $\pi$  & C Filters have nickel barrier, solder plated electrodes and are ideally suited for manufacturers who use various soldering techniques on a multitude of products. However, the amount of solder must be controlled to allow for adequate transfer of heat and mechanical stresses from the PCB to the Filter.

#### Handling:

Extreme care should be exercised when handling ceramic components. They should be treated as fragile components. Excessive force or direct impact to the dielectric may result in chips, cracks or breakage.

#### Cleaning:

Components should be cleaned immediately following the soldering operation to optimize flux removal conditions. Cleaning solutions should be kept clean to avoid contaminating the components. The user should consult the manufacturer's Material Safety Data Sheets for specific handling details.

Excessive temperature differences or excessive agitation during cleaning may damage the filters.

### SQUARE FILTERS

TUSONIX Part Number	Working Volts DC		Cap. (pF)	Capacitance Tolerance	Typical No-Load Insertion Loss (dB) at 25°C per MIL-Std-220		
	85°C	125°C			10MHz	100MHz	1GHz
	4700-006	100			100	100	+80%/-20%
4700-009	100	100	470	+80%/-20%	1	16	40
4700-005	100	100	1000	GMV	7	40	65
4700-003	100	100	2000	GMV	10	45	70
4700-008	100	--	4000	+80%/-20%	13	52	70
4701-002	100	--	6800	+80%/-20%	16	60	70
4701-001	100	--	8200	+80%/-20%	20	65	70
▶4702-000	100	100	100	+80%/-20%	--	1	19
▶4702-001	100	100	470	+80%/-20%	--	12	27
▶4702-002	100	100	1000	+80%/-20%	3	20	35
▶4702-003	100	100	1500	+80%/-20%	5	22	37
▶4702-004	100	100	2500	+80%/-20%	10	25	40
▶4702-005	100	--	4000	+80%/-20%	15	30	45

### ROUND FILTERS

TUSONIX Part Number	Working Volts DC		Cap. (pF)	Capacitance Tolerance	Typical No-Load Insertion Loss (dB) at 25°C per MIL-Std-220		
	85°C	125°C			10MHz	100MHz	1GHz
	4700-059	100			100	100	+80%/-20%
4700-058	100	100	1000	GMV	7	40	65
4700-053	100	100	2000	GMV	10	45	70
4700-056	100	--	5000	+80%/-20%	15	55	70

## X-ON Electronics

Largest Supplier of Electrical and Electronic Components

*Click to view similar products for [Feed Through Capacitors](#) category:*

*Click to view products by [CTS](#) manufacturer:*

Other Similar products are found below :

[PSM4-402Z-20B](#) [CKD110JB1E470S](#) [CKD510JB1E473S](#) [CKD510JB1H221S](#) [CKD510JB1H470S](#) [4700-003MLF](#) [4700-053LF](#) [4701-001MLF](#) [4701-002MLF](#) [SSM1-402E-10B](#) [SSM1-402E-10T1](#) [SSM1-152P-05T1](#) [4700-009MLF](#) [SSM1-101Z-05B](#) [SSM1F-402E-10T1](#) [SSM1-202P-05T1](#) [0805J0500471MATE03](#) [PSM4-103Z-20T0](#) [0805J1000470MATE03](#) [SF0603C101SBNBB](#) [SSM1-402Z-10T1](#) [PSM4F-402Z-20T0](#) [CX0603MRX7R6BB104](#) [CX1206MKX7R9BB104](#) [CX0603MRX7R9BB103](#) [YFF15PC0J105MT000N](#) [NFM15CC222D1A3D](#) [NFM15CC223C1C3D](#) [NFM15CC223C1A3D](#) [NFM18PC225B1A3D](#) [CX0603MRX5R6BB224](#) [CX0603MRX7R9BB103](#) [CX0805MRX7R0BB103](#) [CX0805MRX7R8BB223](#) [CX1206MKX7R7BB224](#) [CX1206MKX7R9BB104](#) [NFM31HK104R1H3L](#) [NFM31HK223R1H3L](#) [NFM15PC224R1A3D](#) [DSS1NB32A223Q91A](#) [DSS1NB31H104Q91A](#) [NFE31PT101C1E9L](#) [NFE31PT220R1E9L](#) [NFE61PT330B1H9L](#) [NFE61PT681B1H9L](#) [NFM31KC104R1H3L](#) [NFM41CC223R2A3L](#) [DSS1NB32A103Q91A](#) [DSS1NB32A102Q91A](#) [NFE31PT471F1E9L](#)