

# Model 536

## High Stability HCMOS TCXO

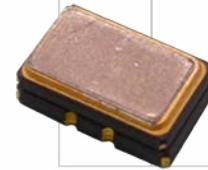

Part Dimensions:  
5.0 × 3.2 × 2.0mm

### Features

- Fundamental Crystal Design
- Frequency Range 10 – 54MHz \*
- Operating Voltage +3.3V
- Frequency Stability, Overall  $\pm 4.6\text{ppm}$  [-40°C to +85°C]
- Operating Temperature Range to -40°C to +105°C
- Voltage Control Option for Frequency Tuning [VCTCXO]
- Enable Function Option Available
- Tape and Reel Packaging, EIA-418

Standard Frequencies – see Page 7 for developed frequencies.  
\* Check with factory for availability of frequencies not listed.

### Applications

- 5G, 4G, LTE
- Femtocells, RRU, BBU
- Military Radio [Manpack]
- Inflight Entertainment
- Autonomous Technologies
- Synchronous Ethernet
- IP Networking
- Medical Imaging
- Stratum 3
- IEEE 1588 Timing
- Wireless Communication
- Test and Measurement

### Description

CTS Model 536 is a high performance Temperature Compensated Crystal Oscillator [TCXO] suitable for applications requiring tight stability, Stratum 3 performance and more. Employing IC technology with HCMOS output and analog temperature compensation engine; coupled with a fundamental quartz crystal M536 has excellent stability and low jitter/phase noise performance.

### Ordering Information

Model	Output Enable	Supply Voltage	Frequency Code [MHz]	Frequency Stability <sup>2</sup>	Temperature Range	Frequency Tuning	Packaging																						
536		L	XXX	X2	I	T	5																						
	<table border="1"> <thead> <tr> <th>Code</th> <th>Function</th> </tr> </thead> <tbody> <tr> <td>Blank</td> <td>No Enable</td> </tr> <tr> <td>E</td> <td>Enable, Pin 3</td> </tr> </tbody> </table>	Code	Function	Blank	No Enable	E	Enable, Pin 3		<table border="1"> <thead> <tr> <th>Code</th> <th>Frequency</th> </tr> </thead> <tbody> <tr> <td colspan="2">Product Frequency Code<sup>1</sup></td> </tr> </tbody> </table>	Code	Frequency	Product Frequency Code <sup>1</sup>			<table border="1"> <thead> <tr> <th>Code</th> <th>Temp. Range</th> </tr> </thead> <tbody> <tr> <td>C</td> <td>-10°C to +70°C</td> </tr> <tr> <td>I</td> <td>-40°C to +85°C</td> </tr> <tr> <td>G</td> <td>-40°C to +105°C<sup>3</sup></td> </tr> </tbody> </table>	Code	Temp. Range	C	-10°C to +70°C	I	-40°C to +85°C	G	-40°C to +105°C <sup>3</sup>		<table border="1"> <thead> <tr> <th>Code</th> <th>Packaging</th> </tr> </thead> <tbody> <tr> <td>5</td> <td>500 pcs./reel</td> </tr> </tbody> </table>	Code	Packaging	5	500 pcs./reel
Code	Function																												
Blank	No Enable																												
E	Enable, Pin 3																												
Code	Frequency																												
Product Frequency Code <sup>1</sup>																													
Code	Temp. Range																												
C	-10°C to +70°C																												
I	-40°C to +85°C																												
G	-40°C to +105°C <sup>3</sup>																												
Code	Packaging																												
5	500 pcs./reel																												
		<table border="1"> <thead> <tr> <th>Code</th> <th>Voltage</th> </tr> </thead> <tbody> <tr> <td>L</td> <td>+3.3Vdc</td> </tr> </tbody> </table>	Code	Voltage	L	+3.3Vdc		<table border="1"> <thead> <tr> <th>Code</th> <th>Stability</th> </tr> </thead> <tbody> <tr> <td>01</td> <td><math>\pm 0.10\text{ppm}</math></td> </tr> <tr> <td>X2</td> <td><math>\pm 0.28\text{ppm}</math></td> </tr> <tr> <td>05</td> <td><math>\pm 0.50\text{ppm}</math></td> </tr> </tbody> </table>	Code	Stability	01	$\pm 0.10\text{ppm}$	X2	$\pm 0.28\text{ppm}$	05	$\pm 0.50\text{ppm}$		<table border="1"> <thead> <tr> <th>Code</th> <th>Frequency Deviation</th> </tr> </thead> <tbody> <tr> <td>T</td> <td>TCXO [No Voltage Control]</td> </tr> <tr> <td>A</td> <td><math>\pm 5\text{ppm} - \pm 10\text{ppm}</math> [VCTCXO]</td> </tr> </tbody> </table>	Code	Frequency Deviation	T	TCXO [No Voltage Control]	A	$\pm 5\text{ppm} - \pm 10\text{ppm}$ [VCTCXO]					
Code	Voltage																												
L	+3.3Vdc																												
Code	Stability																												
01	$\pm 0.10\text{ppm}$																												
X2	$\pm 0.28\text{ppm}$																												
05	$\pm 0.50\text{ppm}$																												
Code	Frequency Deviation																												
T	TCXO [No Voltage Control]																												
A	$\pm 5\text{ppm} - \pm 10\text{ppm}$ [VCTCXO]																												

Notes:

- 1] Refer to document 016-1454-0, Frequency Code Tables. 3-digits for frequencies <100MHz, 4-digits for frequencies 100MHz or greater.
- 2] Frequency vs. Temperature only.
- 3] Available with stability code X2 and 05 only.

**Not all performance combinations and frequencies may be available.  
Contact your local CTS Representative or CTS Customer Service for availability.**

This product is specified for use only in standard commercial applications. Supplier disclaims all express and implied warranties and liability in connection with any use of this product in any non-commercial applications or in any application that may expose the product to conditions that are outside of the tolerances provided in its specification.



## Electrical Specifications

### Operating Conditions

PARAMETER	SYMBOL	CONDITIONS	MIN	TYP	MAX	UNIT
Maximum Supply Voltage	$V_{CC}$	-	-0.5	-	4.6	V
Maximum Control Voltage	$V_C$	-	-0.3	-	$V_{CC}$	V
Supply Voltage	$V_{CC}$	$\pm 5\%$	3.14	3.3	3.47	V
Supply Current	$I_{CC}$	-	-	-	10	mA
Output Load	$C_L$	-	-	-	15	pF
Operating Temperature	$T_A$	-	-10		+70	
			-40	+25	+85	$^{\circ}\text{C}$
Storage Temperature	$T_{STG}$	-	-40		+105	
			-55	-	+125	$^{\circ}\text{C}$

### Frequency Stability

PARAMETER	SYMBOL	CONDITIONS	MIN	TYP	MAX	UNIT
Frequency Range	$f_O$	Frequency stability $\pm 0.10\text{ppm}$		10 - 40		MHz
		Frequency stability $\pm 0.28\text{ppm}$ or $\pm 0.50\text{ppm}$		10 - 54		
<b>Frequency Stability -10°C to +70°C &amp; -40°C to +85°C</b>						
Overall Frequency Stability		Ref. $f_O$ , 20 Years Aging, $\pm 0.28\text{ppm}$ over -40°C to +85°C	-4.6	-	4.6	ppm
Initial Calibration	$\Delta f/f_O$	Initial Calibration @ +25°C, At Time of Shipment	-1.0	-	1.0	ppm
Temperature Only		[fmax - fmin]/2, Over Temperature Range		0.10, 0.28, 0.50		$\pm\text{ppm}$
Voltage Coefficient	$\Delta f/f_{25}$	Supply Voltage, $\pm 5\%$	-0.2	-	0.2	ppm
Load Coefficient		Load, $\pm 10\%$	-0.2	-	0.2	ppm
Aging	$\Delta f/f_{25}$	First Year @ +25°C, nominal $V_{CC}$ and $V_C$	-1.0	-	1.0	ppm
		20 Years @ +25°C, nominal $V_{CC}$ and $V_C$	-3.0	-	3.0	
<b>Frequency Stability -40°C to +105°C</b>						
Overall Frequency Stability		Ref. $f_O$ , 20 Years Aging, $\pm 0.28\text{ppm}$ over -40°C to +105°C	-4.7	-	4.7	ppm
Initial Calibration	$\Delta f/f_O$	Initial Calibration @ +25°C, At Time of Shipment	-0.9	-	0.9	ppm
Temperature Only		[fmax - fmin]/2, Over Temperature Range		0.28, 0.5		$\pm\text{ppm}$
Voltage Coefficient	$\Delta f/f_{25}$	Supply Voltage, $\pm 5\%$	-0.2	-	0.2	ppm
Load Coefficient		Load, $\pm 10\%$	-0.2	-	0.2	ppm
Aging	$\Delta f/f_{25}$	First Year @ +25°C, nominal $V_{CC}$ and $V_C$	-1.0	-	1.0	ppm
		20 Years @ +25°C, nominal $V_{CC}$ and $V_C$	-3.0	-	3.0	

## Electrical Specifications

### Output Parameters

PARAMETER	SYMBOL	CONDITIONS	MIN	TYP	MAX	UNIT
Output Type	-	-		HCMOS		-
Output Voltage Levels	$V_{OH}$	Logic '1' Level, CMOS Load	$0.9V_{CC}$	-	-	V
	$V_{OL}$	Logic '0' Level, CMOS Load	-	-	$0.1V_{CC}$	
Output Duty Cycle	SYM	@ 50% Level, output waveform	45	-	55	%
Rise and Fall Time	$T_{R}$ , $T_{F}$	@ 10%/90% Levels, output waveform	-	-	8	ns
Start Up Time	$T_S$	Application of $V_{CC}$	-	2	5	ms
<b>Enable Function</b>						
Enable Input Voltage	$V_{IH}$	Pin 3 Logic '1', Output Enabled	$0.8V_{CC}$	-	-	V
Disable Input Voltage	$V_{IL}$	Pin 3 Logic '0', Output Disabled	-	-	$0.2V_{CC}$	V
Disable Current	$I_{DIS}$	Pin 3 Logic '0', Output Disabled	-	-	3.5	mA
Enable Time	$T_{PLZ}$	Pin 3 Logic '1'	-	-	5	ms
Phase Noise	-	See Typical Plots	-	-	-	-

### Control Voltage

PARAMETER	SYMBOL	CONDITIONS	MIN	TYP	MAX	UNIT
Control Voltage	$V_C$	$V_{CC} = +3.3V$	0.0	1.65	3.3	V
Frequency Tuning [VCTCXO Only]	$\Delta f/f_0$	Specified $V_C$ Range		$\pm 5$ to $\pm 10$		ppm
Input Impedance	$Z_{Vc}$	-	100	-	-	kOhms
Linearity	L	Best Straight Line Fit	-	$\pm 5$	$\pm 10$	%
Transfer Function	-	-		Positive		-

### Test Circuit

HCMOS

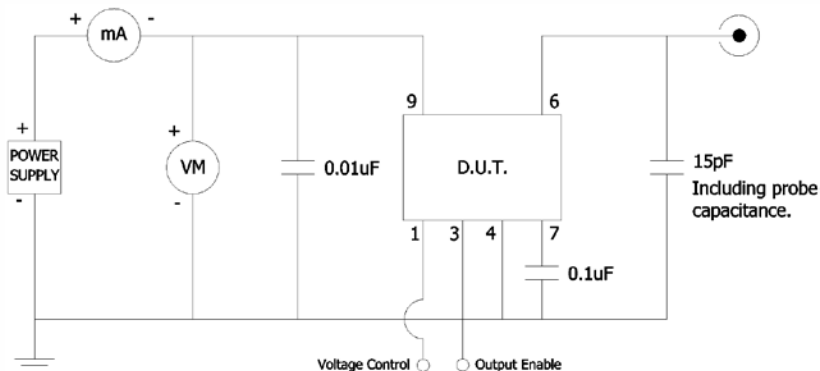

## Electrical Specifications

### Performance Data

Phase Noise [typical]

50MHz,  $V_{CC} = +3.3V$ ,  $T_A = +25^\circ C$

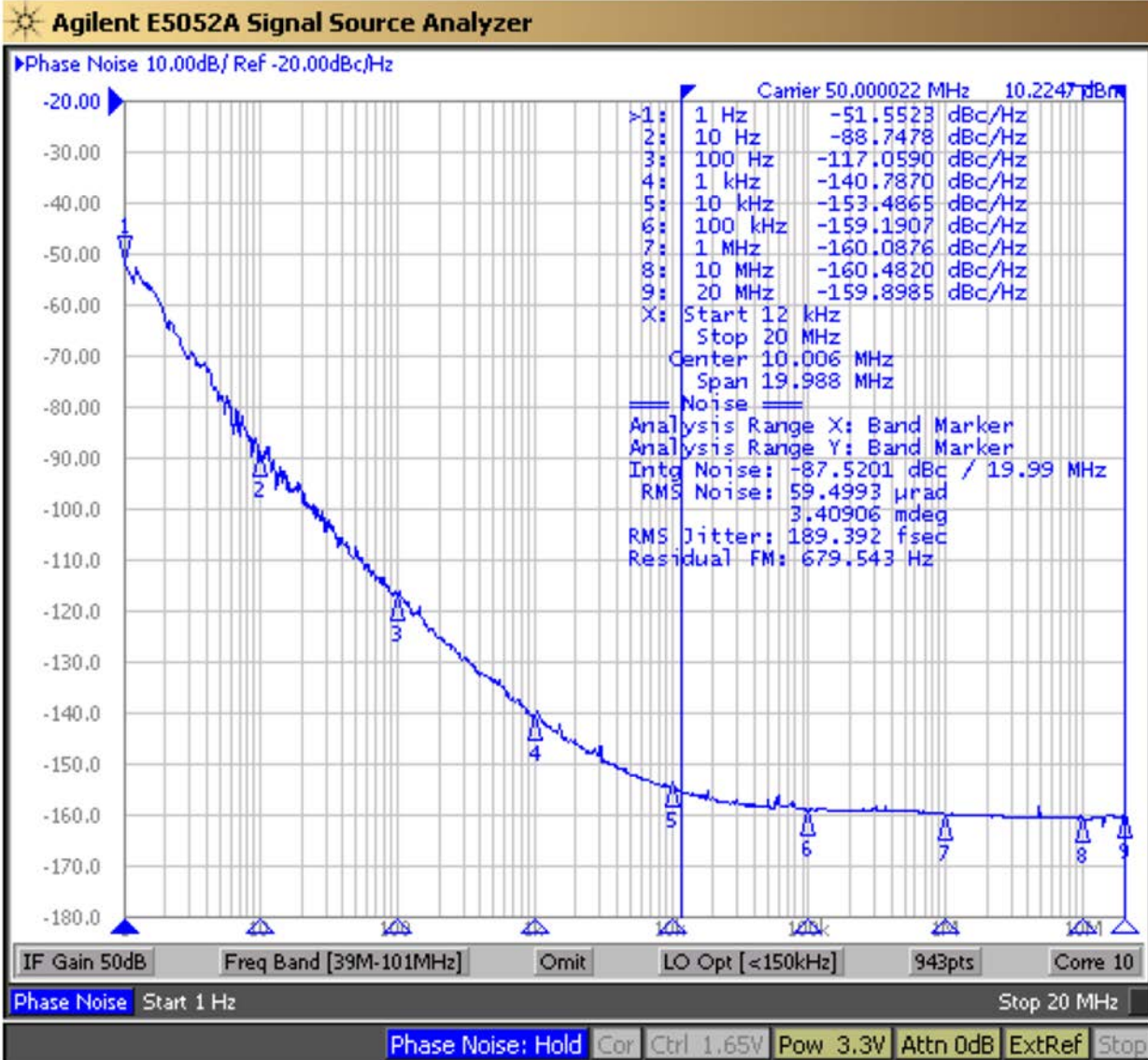

## Mechanical Specifications

### Package Drawing

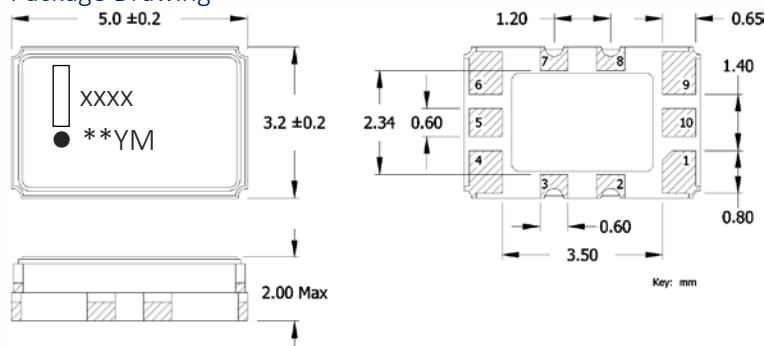

### Marking Information

1. xxxx – Frequency Code, 4-digits. See Page 7.
2. ● – Pin 1 Identifier.
3. \*\* – Manufacturing Site Code.
4. YM – Date Code; Y – year [last digit], M – month. [See Table I for month codes.]
5. – Area for Crystal Lot Code or Date Code.

### Recommended Pad Layout

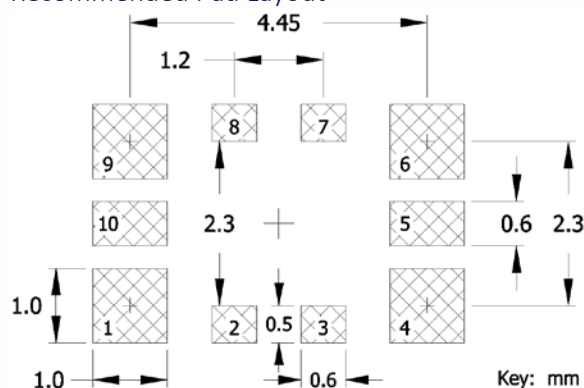

### Notes

1. DO NOT make connections to non-labeled pins or castellations as they may have internal connections used in the manufacturing process.
2. JEDEC termination code (e4). Barrier-plating is nickel [Ni] with gold [Au] flash plate.
3. Reflow conditions per JEDEC J-STD-020; +260°C maximum, 10 seconds.
4. MSL = 1.

### Pin Assignments

Pin	Symbol	Function
1	Vc	Voltage Control Note 1
2	-	Do Not Connect
3	EOH	Enable, Pin 3 [Optional] Note 2
4	GND	Circuit & Package
5	-	Do Not Connect
6	Output	HCMOS
7	-	Vcfilter
8	-	Do Not Connect
9	V <sub>CC</sub>	Supply Voltage
10	-	Do Not Connect

#### Notes

1. Do not connect to Pin 1, if Voltage Control function is not used [TCXO].
2. Do not connect to Pin 3, if Output Enable function is not used.
3. Add 0.1μF capacitor between Pin 7 and ground.

### Table I - Month Code

MONTH	1	2	3	4	5	6	7	8	9	10	11	12
	JAN	FEB	MAR	APR	MAY	JUN	JUL	AUG	SEP	OCT	NOV	DEC
MONTH CODE	1	2	3	4	5	6	7	8	9	X	Y	Z

### Packaging - Tape and Reel

#### Tape Drawing

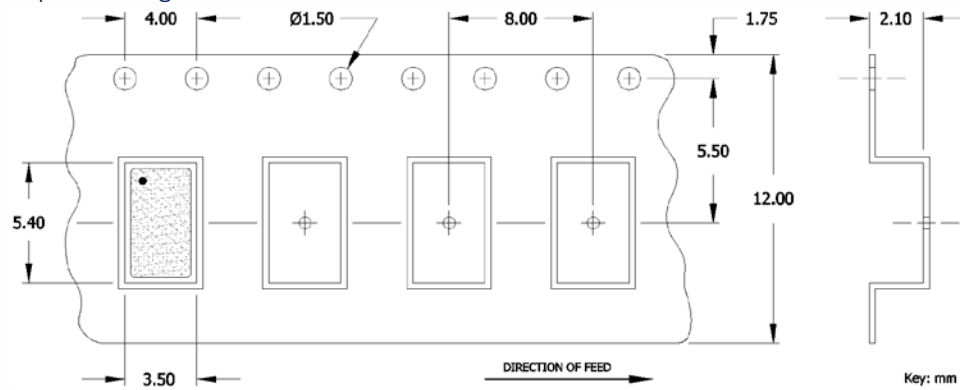

#### Reel Drawing

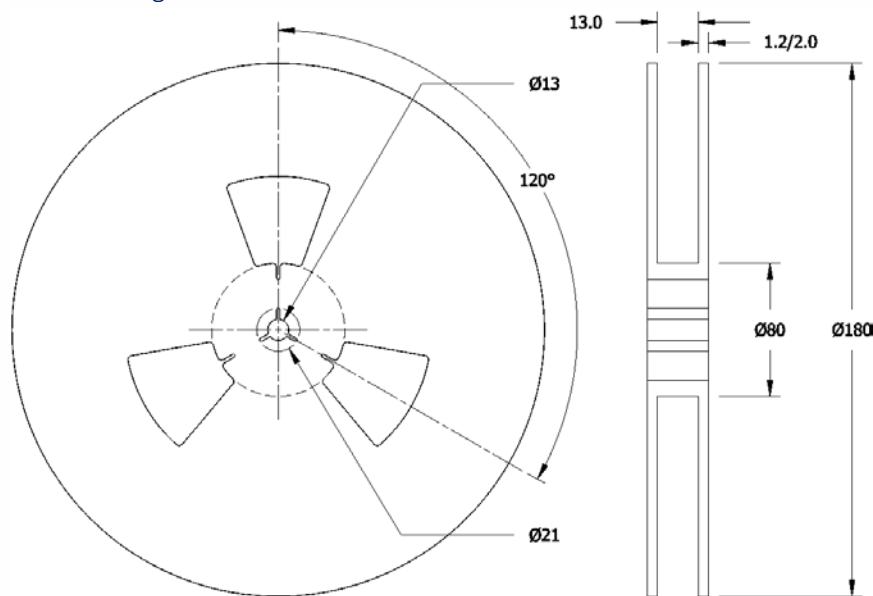

#### Notes

1. Device quantity is 500 pieces maximum per 180mm reel.
2. Complete CTS part number, frequency value and date code information must appear on reel and carton labels.



## Addendum

### Available Frequencies for Stability $\pm 0.50\text{ppm}$ – MHz

FREQUENCY	ORDERING CODE	MARKING CODE	FREQUENCY	ORDERING CODE	MARKING CODE	FREQUENCY	ORDERING CODE	MARKING CODE
10.000000	100	1000	38.880000	388	3888			
19.200000	192	1920	40.000000	400	4000			
20.000000	200	2000						
25.000000	250	2500						
38.400000	384	3840						

### Available Frequencies for Stability $\pm 0.28\text{ppm}$ – MHz

FREQUENCY	ORDERING CODE	MARKING CODE	FREQUENCY	ORDERING CODE	MARKING CODE	FREQUENCY	ORDERING CODE	MARKING CODE
10.000000	100	1000	38.880000	388	3888			
19.200000	192	1920	40.000000	400	4000			
20.000000	200	2000						
25.000000	250	2500						
38.400000	384	3840						

### Available Frequencies for Stability $\pm 0.10\text{ppm}$ – MHz

FREQUENCY	ORDERING CODE	MARKING CODE	FREQUENCY	ORDERING CODE	MARKING CODE	FREQUENCY	ORDERING CODE	MARKING CODE
10.000000	100	1000						
20.000000	200	2000						
25.000000	250	2500						

## X-ON Electronics

Largest Supplier of Electrical and Electronic Components

*Click to view similar products for [TCXO Oscillators](#) category:*

*Click to view products by [CTS](#) manufacturer:*

Other Similar products are found below :

[SiT5000AI-3D-33E0-10.000000X](#) [THD3031035LK280005-10.0M](#) [AST3TDATAACJ5-10.0000MHz](#) [AST3TDATAACJ5-20.0000MHz](#)  
[AST3TDA53TACJ2-19.2000MHz](#) [AST3TDA53TACJ2-38.8800MHz](#) [AST3TDATAACJ5-19.2000MHz](#) [AST3TDATAACJ5-38.8800MHz](#)  
[SiT5155AI-FK-33E0-10.000000F](#) [CVT32-10.000](#) [SIT5356AI-FQ-33E0-25.000000X](#) [SIT5357AI-FQ-33N0-100.000000X](#) [DS32KHZSN+T&R](#)  
[XTCLH25M000THJA0P0](#) [LFTCXO075793Cutt](#) [LFTCXO077229Cutt](#) [LFPTXO000002Bulk](#) [LFTCXO077228Cutt](#) [LFTCXO077230Cutt](#)  
[LFTCXO075792Cutt](#) [AST3TQ53-T-10.000MHz-5-C](#) [ATX-11-F-26.000MHz-F05-T](#) [ATX-11-F-27.000MHz-F05-T](#) [ATX-12-F-32.000MHz-](#)  
[F05-T](#) [ATX-13-F-26.000MHz-F05-T](#) [I538-2O7- 25.000 MHz](#) [I537-2O7- 39.000 MHz](#) [I537-2O7- 25.000 MHz](#) [ECS-TXO-2016-33-320-TR](#)  
[ECS-TXO-2016-33-120-TR](#) [ECS-TXO-2016-33-250-TR](#) [ECS-TXO-2016-33-200-TR](#) [ECS-TXO-20CSMV-AC-260-AY-TR](#) [TG2016SMN](#)  
[26.0000M-MCGNNM0](#) [TG2016SMN 25.0000M-MCGNNM0](#) [TG2016SMN 25.0000M-MCGNNM3](#) [TG2520SMN 16.0000M-MCGNNM0](#)  
[TG2520SMN 25.0000M-MCGNNM0](#) [TG2520SMN 40.0000M-ECGNNM0](#) [TG2520SMN 24.0000M-ECGNNM0](#) [TG2520SMN 20.0000M-](#)  
[MCGNNM0](#) [TG2520SMN 30.0000M-ECGNNM0](#) [TG2520SMN 30.000M-MCGNNM0](#) [TG2520SMN 27.0000M-MCGNNM3](#) [TG2520SMN](#)  
[32.0000M-MCGNNM3](#) [TG2520SMN 32.0000M-ECGNNM3](#) [LFPTXO000001Bulk](#) [LFTCXO063711BULK](#) [LFTCXO063713BULK](#)  
[LFTCXO063715BULK](#)